

**NOTICE OF MEETING AND PUBLIC HEARING OF THE  
THATCHER TOWN COUNCIL  
October 16, 2017**

Pursuant to A.R.S. 38 431.02, notice is hereby given to the members of the Town Council of the Town of Thatcher and the general public that the Town Council will hold a **Public Hearing and its Regular Meeting that are open to the public on October 16, 2017 beginning at 6:00 PM., in the Council Chambers, Thatcher Town Hall, located at 3700 West Main Street, Thatcher, Arizona.**

**AGENDA**

1. Welcome and Call Meeting to Order.

2. Pledge of Allegiance.

3. Roll Call.

4. **PUBLIC HEARING:**

A. Preliminary Platt for Daley Heights.

B. Liquor License Agent Change Giant Store #632

C. Liquor License Agent Change Giant Store #654

D. Liquor License Agent Change Giant Store #902

5. **OPEN CALL TO THE PUBLIC:**

Anyone wishing to address the Council on an issue not on the agenda is allowed to speak at this time. Comments are limited to 5 minutes and the Council may only direct staff to study the matter, respond to criticism or schedule the matter for a future meeting.

6. **PUBLIC APPEARANCES:**

7. **CONSENT AGENDA:**

Action Item

A. Approve minutes of the September 18, 2017 Regular Council Meeting.

B. Planning and Zoning Monthly Report.

C. Police Monthly Report.

D. Approval of Invoices.

E. Financial Reports.

8. **OLD BUSINESS:**

Discussion, consideration and possible action

**11. NEW BUSINESS:** Discussion, consideration and possible action

- A. Decision on Rezoning Request.
- B. Decision on Liquor License Agent Change Giant Store #632
- C. Decision on Liquor License Agent Change Giant Store #654
- D. Decision on Liquor License Agent Change Giant Store #902

**12. INFORMATIONAL ITEMS:**

- A. Town Manager's Report:
- B. Fire Department Report.
- C. Police Department Report.
- D. Council Reports.

**13. ADJOURNMENT**

The agenda may be inspected at the Thatcher Town Hall, 3700 W. Main Street, Thatcher, Arizona. All individuals addressing the Council shall limit their presentations or comments to 5 minutes or less and no more than twice on any one subject.

Handicapped individuals with special accessibility needs may contact Heath Brown, ADA Coordinator the Town of Thatcher, at (928) 428-2290 or (800) 367-8938 (TDD Relay). If possible, such requests should be made 72 hours in advance.

Posted by: \_\_\_\_\_

Date:Time:\_\_\_\_\_

# MINUTES OF THE WORK SESSION OF THE THATCHER PLANNING & ZONING COMMISSION

October 10, 2017

MEMBERS PRESENT: Chairman Ramon Morales, Members Jerry Hoopes, David Griffin, Bret Whitmer, Ray Tuttle, Eddy Carlton, Tom Palmer, and Town Eng. Heath Brown

MEMBERS ABSENT: none

VISITORS: Tom Elam, Donna Elam, Doug Spencer, Lori Rhinehart, Bobette Daley, David Bryce, Shakir Gushgari

Chairman Ramon Morales called the meeting to order at 7:01 PM, establishing that there was a quorum.

## **2. Pledge of Alliance**

## **3. Roll Call**

## **4. Approval of Minutes**

Chairman Morales asked if there was any discussion of the June 2017 meeting minutes. A motion was made by Mr. Tom Palmer to accept the minutes and seconded by Dr. Ray Tuttle. The vote was a unanimous yes and the minutes were approved.

## **5. Public Hearing-Discussion:**

### **A. Consideration of Preliminary Plat for the Daley Heights Subdivision located south of Daley Estates.**

Chairman Morales asked if there was any discussion on the proposed preliminary plat. Mr. Tom Elam said he had some questions. Where will traffic enter the subdivision? Will the increased traffic cause problems? Where will the utilities come from? Will the retention basins hold water, smell bad, and bring mosquitos? Mr. Heath Brown answered; most traffic will enter through the intersection of Pinaleno Mountain Dr. and Valley View Rd. There are currently over 500 homes in Daley Estates and this subdivision would add 192, for about a 30% increase in traffic. The streets in the area should be able to handle that without causing any issues. Utilities will all be underground and will connect to the existing utility lines at the south end of existing Daley Estates. The retention basins are all adjacent to washes, and will have small bleed-off lines that drain into the washes. That way the basin will fill up in a storm, but then drain within 36 hours, so that smell and mosquitos should not be a problem.

Ms. Donna Elam asked what type of homes would go in? Mobile homes? Mr. Shakir Gushgari answered that the homes would be 1,800 to 2,400 SF site built homes. Mr. Elam asked about dust control. Mr. Brown answered that the developer must take measures to keep dust down.

Dr. David Bryce asked about the water pressure for the development. Mr. Brown and Mr. Gushgari responded that there are issues with water pressure and flow the farther south the development goes. For the first phase or two, pressure and flows are most likely not an issue, but the later phases will need special infrastructure constructed to ensure proper flows and pressure. The City of Safford is involved and will approve all proposed improvements.

## **6. Decision on Public Hearing:**

### **A. Approval of Daley Heights Preliminary Plat.**

Mr. Griffin asked Mr. Brown about the lot at the west side of the intersection of Valley View Rd. and Pinaleno Mountain Dr., that is using the proposed alignment of Valley View Rd. for storage and has a shed there. Mr. Brown responded that that area is already ROW owned by the Town, and they have encroached there without permission, and will have to move there possessions.

Mr. Tom Palmer noted that the first page of the plat has two contradictory statements regarding the character of the development and the method by which properties will be sold; this should be corrected to state the true intent, and not contradict each other. He noted that about 1/3 of the lots in phase 1 are in the flood plain and wanted to know how this would be addressed. Mr. Gushgari stated that the elevation of the lots within the floodplain will be raised to one foot above the flood elevation and a flood certificate will be issued for the lots. Mr. Palmer asked if a FEMA map revision would be completed, or would the owners have to pay flood insurance? Mr. Gushgari said that a map revision is not planned. Mr. Palmer also noted that under zoning on the first page it states that this is multiple zones of R-2 and A-R, when it looks like from the zone map all the property is zoned R1-8. Mr. Brown stated that Mr. Palmer is correct and the plat needs corrected.

There was discussion about the smaller washes and sheet flooding that occurs across the existing property. It is understood that these issues must be fully addressed in the Final Plat, improvement plans, and the final drainage report. It is also understood that the improvements completed by the developer cannot change the amount of storm water on any surrounding properties.

Mr. Bret Whitmer asked if this plat meets the Town's new Subdivision Standards? Mr. Brown responded that he did review the plat for compliance, and after changes made to the plat, it does now comply. Mr. Whitmer asked about amenities within the subdivision. Mr. Brown stated that after the initial review of the plat there were no amenities, and he instructed the developer that amenities are required for a subdivision of this size. The developer then added a gazebo and barbeque grill at two of the detention basins. Mr.

Whitmer asked about lighting and if the utilities would be underground or overhead. Mr. Brown stated that streetlights will be required and that all utilities must be underground.

Mr. Griffin made a motion to recommend the approval of the Daley Heights Subdivision with the corrections noted in the discussion. Mr. Jerry Hoopes seconded the motion. The vote was a unanimous yes and the motion passed.

**8. Staff Report:**

Mr. Brown gave a status report regarding the Daley Estates roundabout, park improvements, and street improvements; the CDBG playground surfacing project, and other projects and work happening in the Town.

**9. Adjournment:**

Mr. Palmer made a motion to adjourn and Mr. Carlton seconded it. The vote was a unanimous yes and the meeting adjourned.

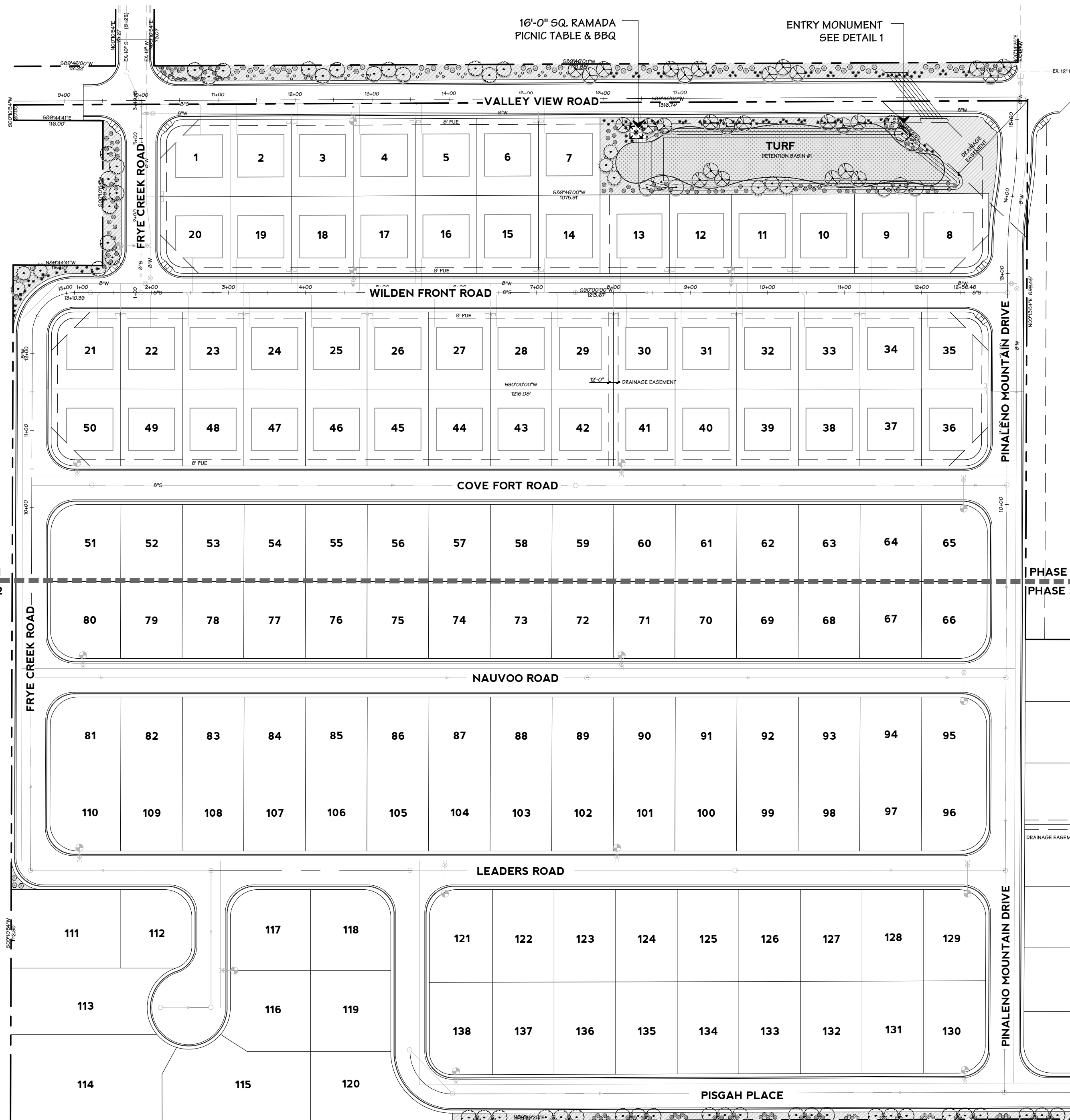

**1 ENTRY MONUMENT**  
 SCALE: 1/4" = 1'-0"

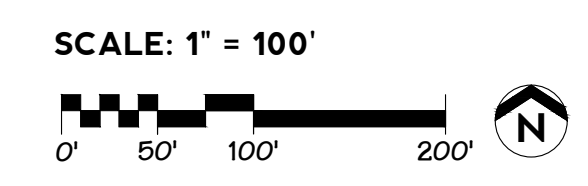
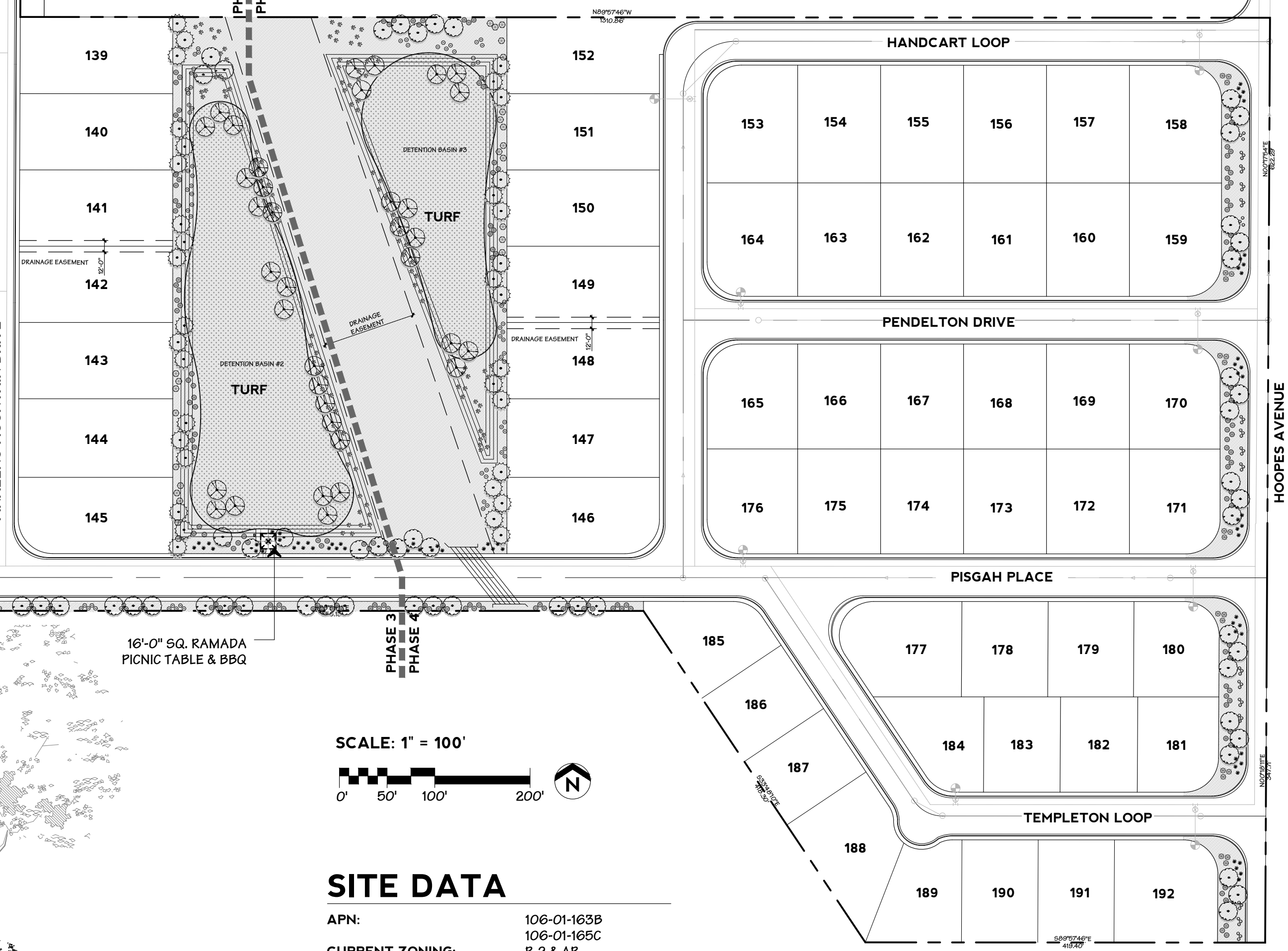
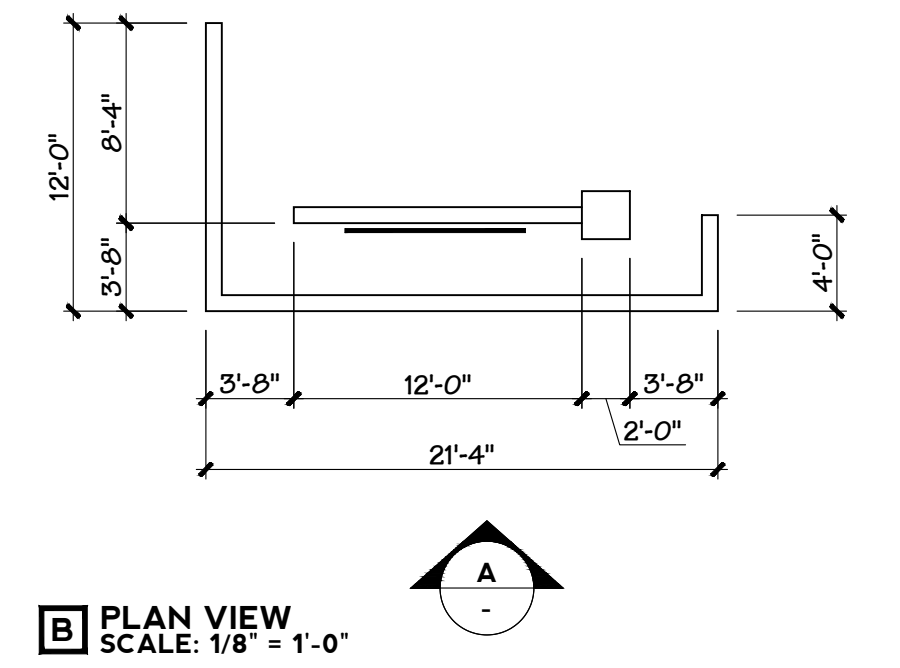
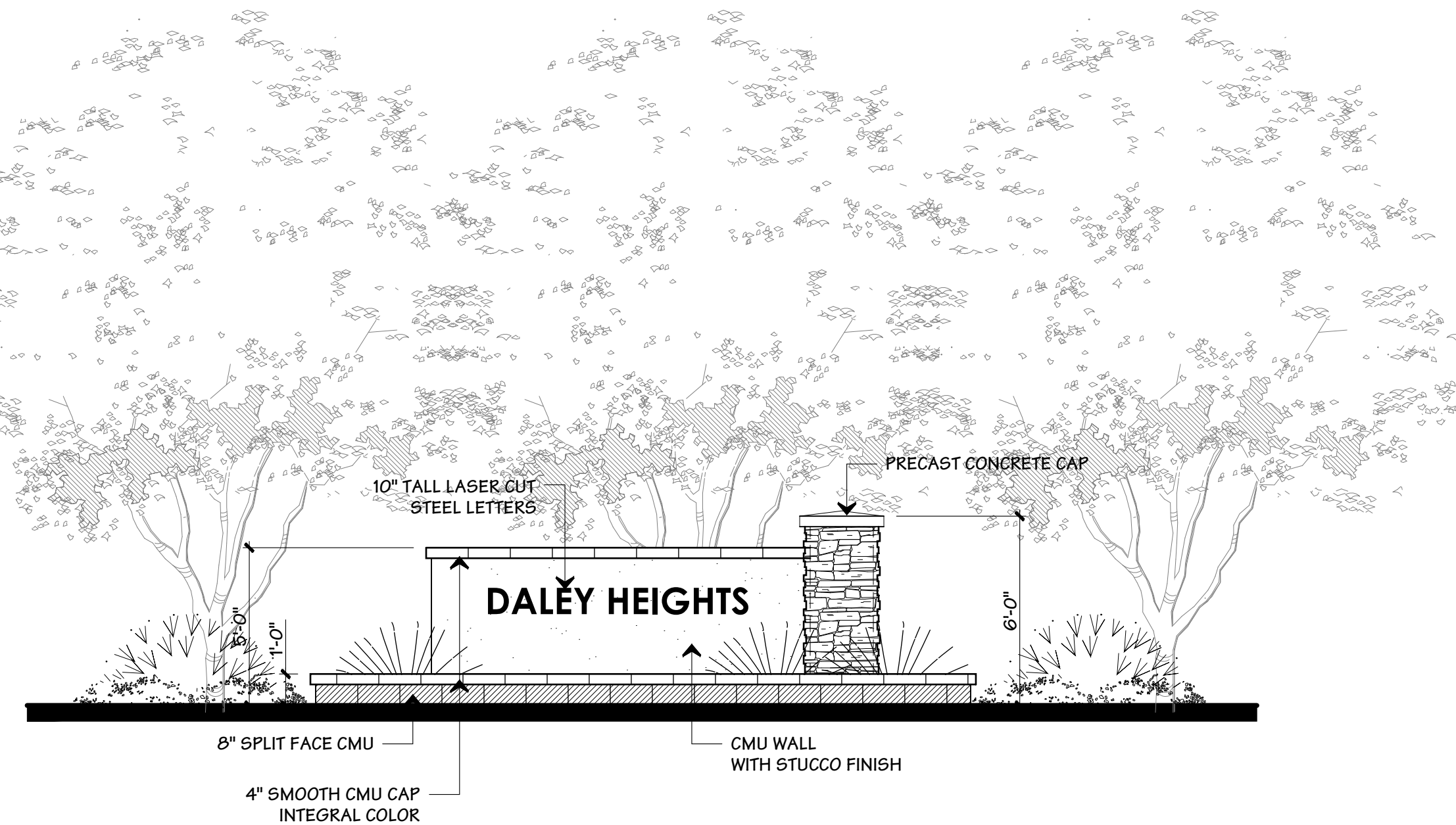

**SITE DATA**  
 APN: 106-01-163B  
 106-01-165C  
 R-2 & AR  
 CURRENT ZONING:  
 GROSS AREA: 62.44 AC  
 OPEN SPACE: 7.65 AC (12% OF SITE AREA)  
 ACTIVE OPEN SPACE: 1.81 AC (23% OF OPEN SPACE)

**LANDSCAPE LEGEND & SCHEDULE**

BOTANICAL NAME	SMYMBOL	COMMON NAME	SIZE	QTY
<b>TREES</b>				
PISTACIA CHINENSIS 'RED PUSH'		RED PUSH CHINESE PISTACHE - STANDARD TRUNK	24" BOX	63
PINUS ELDERICA		MONDEL PINE - STANDARD TRUNK	24" BOX	44
FAN TEX ASH		FRAXINUS VELUTINA - STANDARD TRUNK	24" BOX	99
DESERT WILLOW		CHILOPSIS LINEARIS - STANDARD TRUNK	15 GAL.	6
<b>SHRUBS</b>				
BOUGAINVILLEA SPECIES		BUSH BOUGAINVILLEA	5 GAL.	47
TECOMA X 'ORANGE JUBILEE'		ORANGE JUBILEE	5 GAL.	82
LEUCOPHYLLUM FRUTESCENS		GREEN CLOUD SAGE	5 GAL.	266
EROMOPHILA MACULATA		VALENTINE BUSH	5 GAL.	124
<b>ACCENTS</b>				
HESPERALOE PARVIFOLIA		RED YUCCA	5 GAL.	90
DASYLIRION WHEELERI		DESERT SPOON	3 GAL.	190
MUHLENBERGIA RIGENS		DEER GRASS	5 GAL.	118
<b>GROUNDCOVER</b>				
LANTANA X 'NEW GOLD'		YELLOW LANTANA	1 GAL.	28
LANTANA MONTIVENDENSIS		PURPLE TRAILING LANTANA	1 GAL.	8
<b>TURF</b>				
NATURAL TURF		NATURAL TURF	SOD	106,019 S.F.
CYNODON DACTYLON 'MIDIRON'		CYNODON DACTYLON 'MIDIRON'	S.F.	5 F.
<b>TOP DRESSING</b>				
DECOMPOSED GRANITE		COLOR: SANTA FE BROWN	1/2" SCREENED	186,629 S.F.
			2" DEEP MINIMUM	

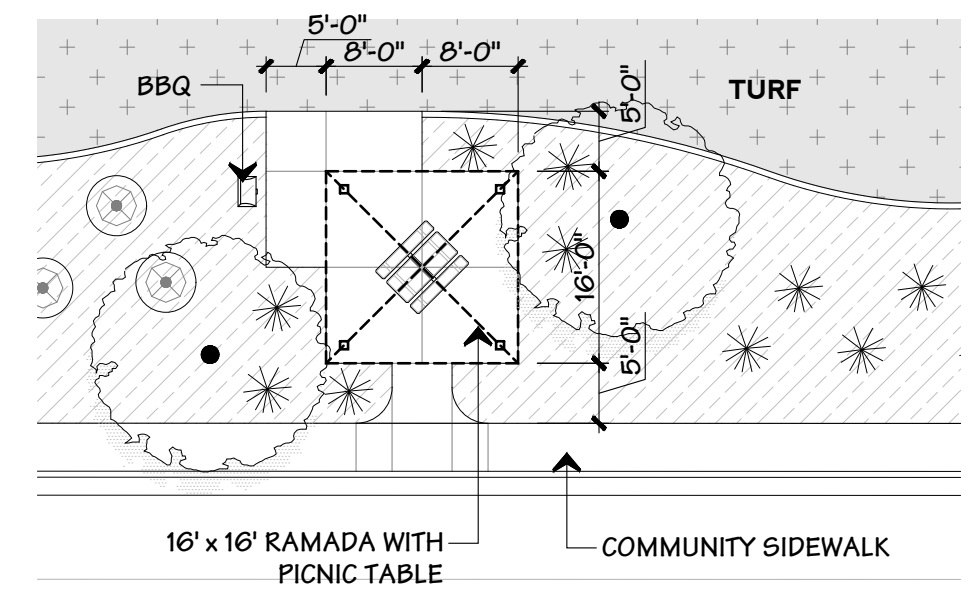

**A TYPICAL RAMADA AREA**  
 SCALE: 1/16" = 1'-0"

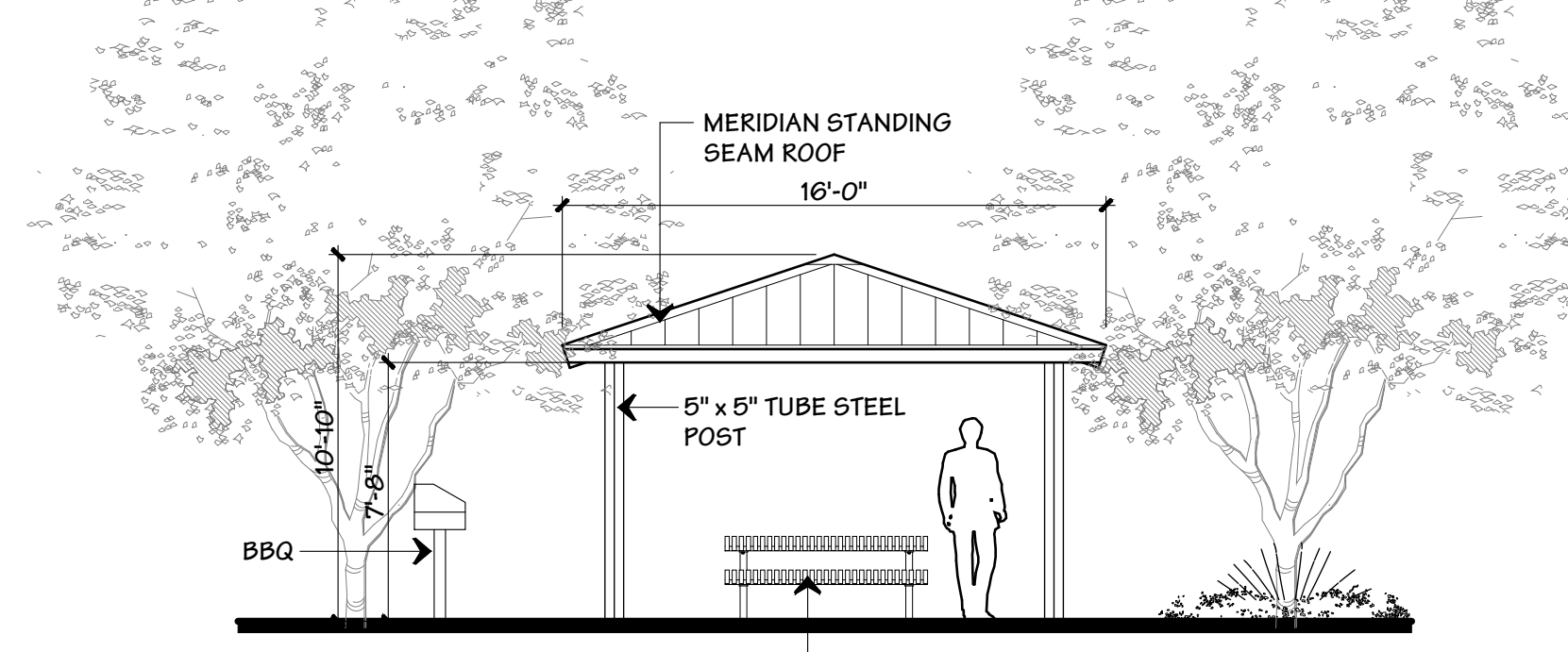

**A RAMADA ELEVATION**  
 SCALE: 3/16" = 1'-0"

**2 RAMADA AREA WITH PICNIC TABLE AND BBQ**

**NOTES**

- NO STRUCTURE SHALL BE CONSTRUCTED OR ANY VEGETATION BE PLANTED WITHIN THE DRAINAGE EASEMENTS WHICH WOULD IMPEDE THE FLOW OF WATER THROUGH THE RETENTION BASINS' STORAGE FACILITIES.
- CONSTRUCTION WITHIN EASEMENTS SHALL BE LIMITED TO WOOD, WIRE OR REMOVABLE SECTION TYPE FENCING OR WALLS.
- THIS DEVELOPMENT IS LOCATED WITHIN THE CITY OF SAFFORD WATER SERVICE AREA AND HAS BEEN DESIGNATED AS HAVING AN ASSURED WATER SUPPLY.
- THE HOMEOWNERS ASSOCIATION (UPON FORMATION), INCLUDING ALL PROPERTY OWNERS IN THIS DEVELOPMENT, SHALL HAVE THE RESPONSIBILITY FOR MAINTAINING ALL COMMON AREAS AND DRAINAGE FACILITIES IN ACCORDANCE WITH APPROVED PLANS.
- STRUCTURES AND LANDSCAPING AT THE INTERSECTIONS OF A MAJOR STREET WITH A LOCAL STREET WITHIN A TRIANGLE MEASURING 50' X 50' ALONG THE RIGHT-OF-WAY LINES, SHALL BE MAINTAINED AT A MAXIMUM HEIGHT OF THREE FEET.
- ELECTRIC LINES TO BE INSTALLED PER ARIZONA CORP. COMMISSION GENERAL ORDER U-48.
- THE EXISTING PORTION OF HOOPES AVENUE SHALL CONNECT INTO THE PROPOSED PORTION OF HOOPES AVENUE FRONTING THE SUBJECT DEVELOPMENT'S EAST BOUNDARY DURING PHASE 4 IMPROVEMENTS.

**UTILITIES AND REFUSE SERVICES**

THE DEVELOPMENT WILL EXTEND UTILITIES TO EACH LOT TO INCLUDE ELECTRIC, TELEPHONE, COMMUNICATION AND GAS SERVICES. IT WILL ALSO PROVIDE REFUSE COLLECTION SERVICES THROUGH THE TOWN OF THATCHER.

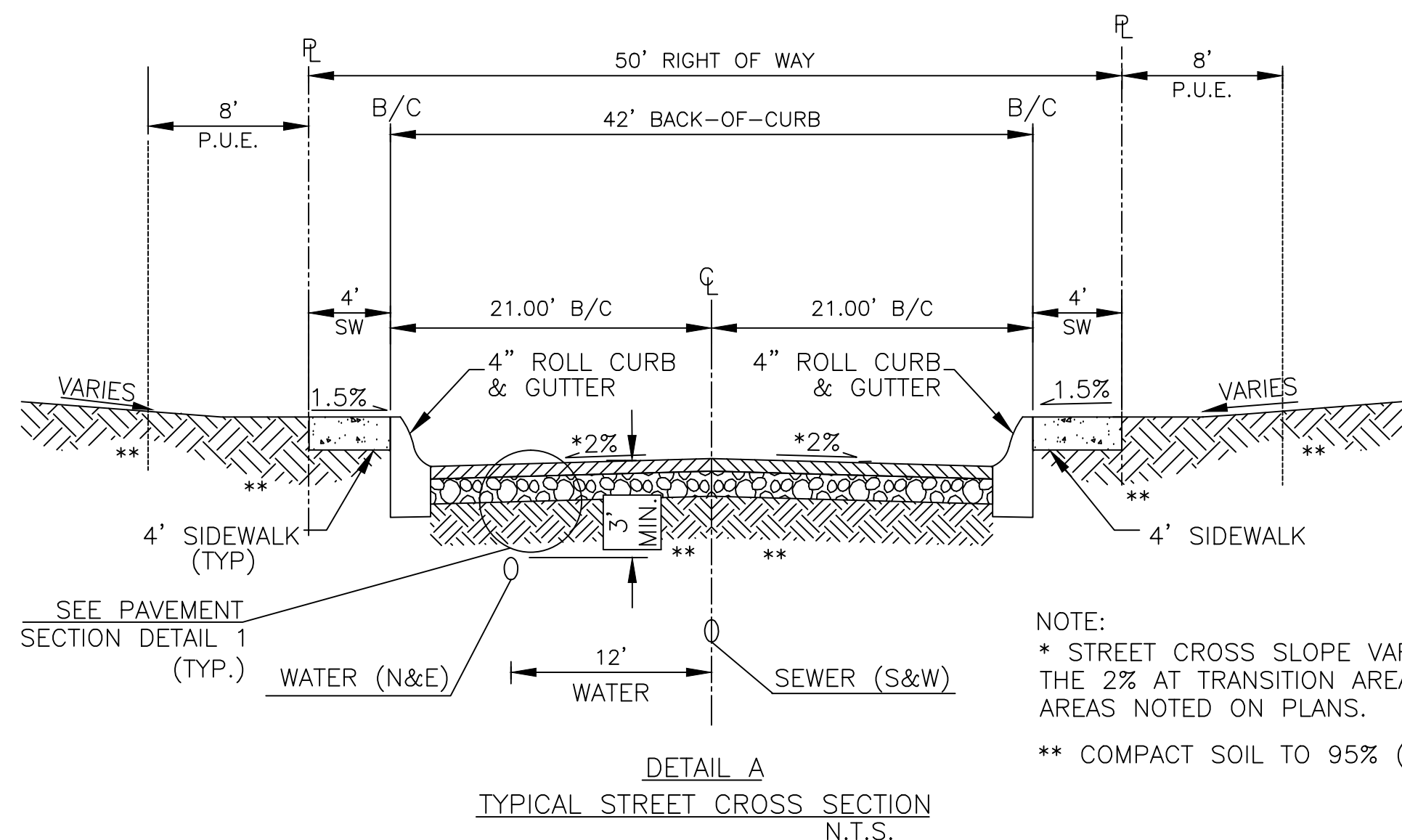

NOTE:  
\* STREET CROSS SLOPE VARIES FROM THE 2% AT TRANSITION AREAS AND AREAS NOTED ON PLANS.  
\*\* COMPACT SOIL TO 95% (MIN.)

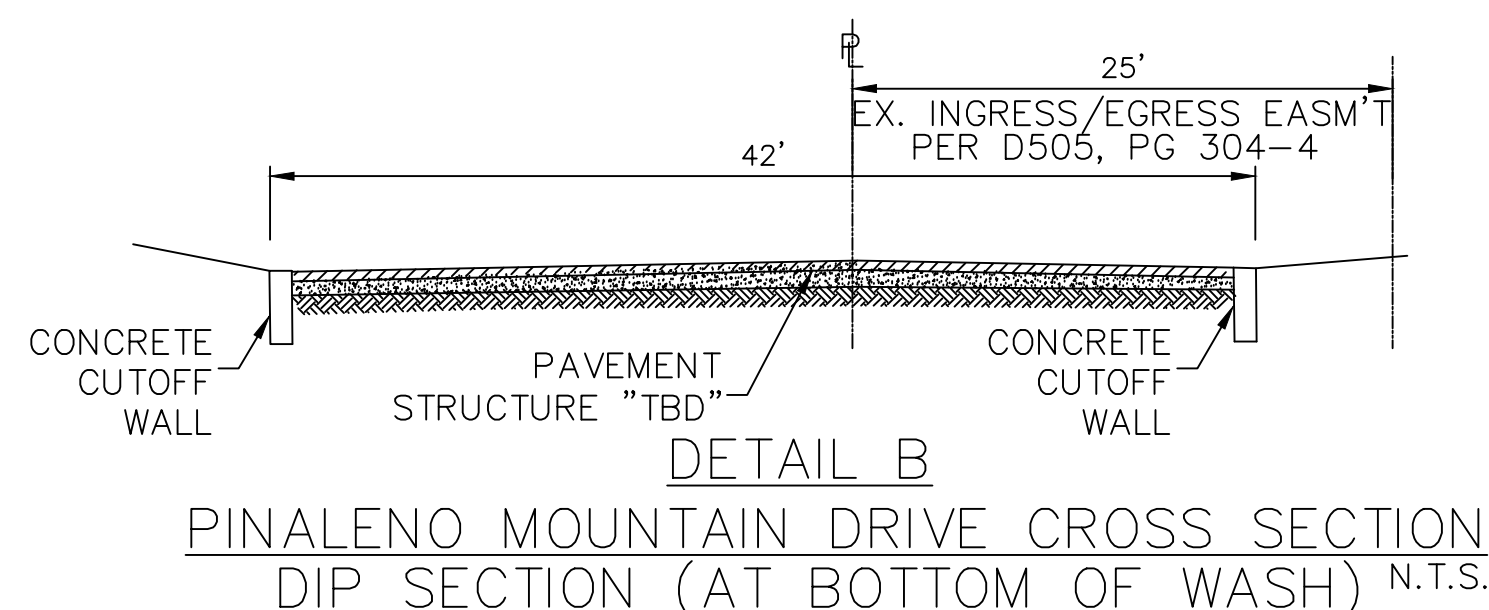

NOTE:  
CONTRACTOR TO NOTE THAT UTILITY PLACEMENT DURING CONSTRUCTION ACTIVITIES MAY NOT PROVIDE ADEQUATE COVER AT SUBGRADE. CONTRACTOR IS RESPONSIBLE TO PROVIDE ADEQUATE PROTECTION FOR UTILITIES AT ALL TIMES.  
\*\* COMPACT SOIL TO 95% (MIN.)  
PER MAG SPEC. 321 (AC THICKNESS "TBD")  
PER MAG SPEC. 310 (ABC THICKNESS "TBD")  
SUBGRADE PREPARATION (THICKNESS "TBD")  
PER MAG SPEC. 301

**DEVELOPMENT CHARACTER STATEMENT**

OVERALL NATURE OF DEVELOPMENT - THE VISION IS TO INTEGRATE THIS DEVELOPMENT INTO THE SURROUNDING COMMUNITY AND MAINTAINING LOT SIZES SIMILAR TO DALEY ESTATES DEVELOPMENT TO THE NORTH WHILE KEEPING MONUMENT SIGNAGE TO A MINIMUM. THIS VISION WILL HELP MITIGATING ANY "BROKEN SUBDIVISION" ISSUES. IT IS ENVISIONED THAT THE PROPOSED IMPROVEMENT WILL OCCUR ON A PHASED BASIS AND STREETS AND INFRASTRUCTURE IMPROVEMENTS WILL OCCUR AS EACH PHASE IS DEVELOPED. THIS CONCEPT APPEARS TO BE THE BEST APPROACH GIVEN THE SIZE OF THE LOCAL MARKET WHILE ALSO ALLOWING FOR AN OVERALL COMMUNITY FEEL AT BUILD OUT. REPRESENTATIVE IMAGES AND PICTURES OF HOUSING PRODUCT WILL BE PROVIDED BY THE DEVELOPER IN A SEPARATE PACKAGE. HOMES WILL RANGE FROM ABOUT 1300 S.F. TO 2500 S.F. IN ONE AND TWO STORY MODELS. HOMES WILL BE PROVIDED BY WATER SERVICES, SEWER SERVICES, ELECTRIC AND COMMUNICATION SERVICES.

# PRELIMINARY PLAT FOR DALEY HEIGHTS RESIDENTIAL COMMUNITY

AN R-2 PLANNED RESIDENTIAL COMMUNITY WITHIN A PARCEL LOCATED IN SOUTHEAST QUARTER OF THE NORTHEAST QUARTER OF SECTION 27 AND IN A PORTION OF THE SOUTH HALF OF THE SOUTHWEST QUARTER OF THE NORTHWEST QUARTER OF SECTION 26 AND A PORTION OF THE NORTH HALF OF THE NORTHWEST QUARTER OF THE SOUTHWEST QUARTER OF SECTION 26, TOWNSHIP 7 SOUTH, RANGE 25 EAST OF THE GILA AND SALT RIVER BASE AND MERIDIAN, GRAHAM COUNTY, SCOTTSDALE, ARIZONA.

**EXISTING CONDITION DATA**

THE SUBJECT PARCEL IS A VACANT PARCEL WITH NATURAL DESERT VEGETATION IN ITS EXISTING CONDITION WITH NO BUILDINGS OR STRUCTURES. SITE IS TRAVERSED BY EXISTING NATURAL WASH.

**PROPOSED CONDITION / IMPROVEMENTS DATA**

THE SUBJECT PARCEL IS PROPOSED TO BE DEVELOPED INTO A SINGLE FAMILY RESIDENTIAL DEVELOPMENT WITH 192 UNITS IN 4 SEPARATE PHASES. DEVELOPMENT IS PROPOSED WITH ITS ASSOCIATED GRADING, PAVING, INFRASTRUCTURE AND LANDSCAPE CONSTRUCTION.

**PROPOSED PHASING**

THE PROPOSED DEVELOPMENT IS PLANNED TO BE PHASED INTO POTENTIAL 4 SEPARATE PHASES, PHASE 1 BEING THE FIRST PHASE, CONSISTING OF 35 SINGLE FAMILY RESIDENTIAL UNITS. PHASE 2 MAY ALSO BE COMBINED WITH PHASE 1. SUBSEQUENT PHASES WILL BE PLANNED AND SUBMITTED TO THE TOWN OF THATCHER AT FUTURE DATES.

**LOT AREAS TABLE**

Lot No.	Area (square feet)	Lot No.	Area (square feet)
Tract A: 50,437.53			
1	8925.63	19	8002.75
2	8147.28	20	8846.08
3	8123.59	21	8800.44
4	8150.29	22	8003.67
5	8075.88	23	8001.43
6	8052.06	24	8002.18
7	8020.15	25	8004.75
8	9572.68	26	8005.51
9	8270.76	27	8006.27
10	8244.70	28	8007.02
11	8218.63	29	8007.78
12	8192.57	30	8009.62
13	9233.37	31	8004.45
14	8130.00	32	8004.62
15	8098.05	33	8020.15
16	8074.28	34	8005.56
17	8100.75	35	8447.23
18	8026.59		

**SEWAGE DISPOSAL METHOD**

THE SUBJECT PARCEL PROPOSES TO COLLECT ITS ONSITE GENERATED SANITARY SEWER VIA GRAVITY SYSTEM AND DISPOSE OF IT INTO THE EXISTING TOWN SYSTEM AT TWO LOCATIONS: 1) EX. 10" SEWER LINE AT VALLEY VIEW AND FRYE CREEK ROADS AND 2) EX. 8" SEWER LINE AT VALLEY VIEW AND HOOPES AVENUE, AS SHOWN ON SHEET 2 OF THE PRELIMINARY PLAT.

**WATER SUPPLY METHOD**

THE SUBJECT PARCEL PROPOSES TO SERVE ITS LOTS WITH WATER SUPPLY AND FIRE FLOW DEMAND BY CONNECTING ITS PROPOSED 8" ONSITE WATER DISTRIBUTION SYSTEM INTO THE EXISTING CITY OF SAFFORD WATER DISTRIBUTION SYSTEM AT THREE LOCATIONS ALONG VALLEY VIEW ROAD, AS SHOWN ON SHEET 2 OF THE PRELIMINARY PLAT.

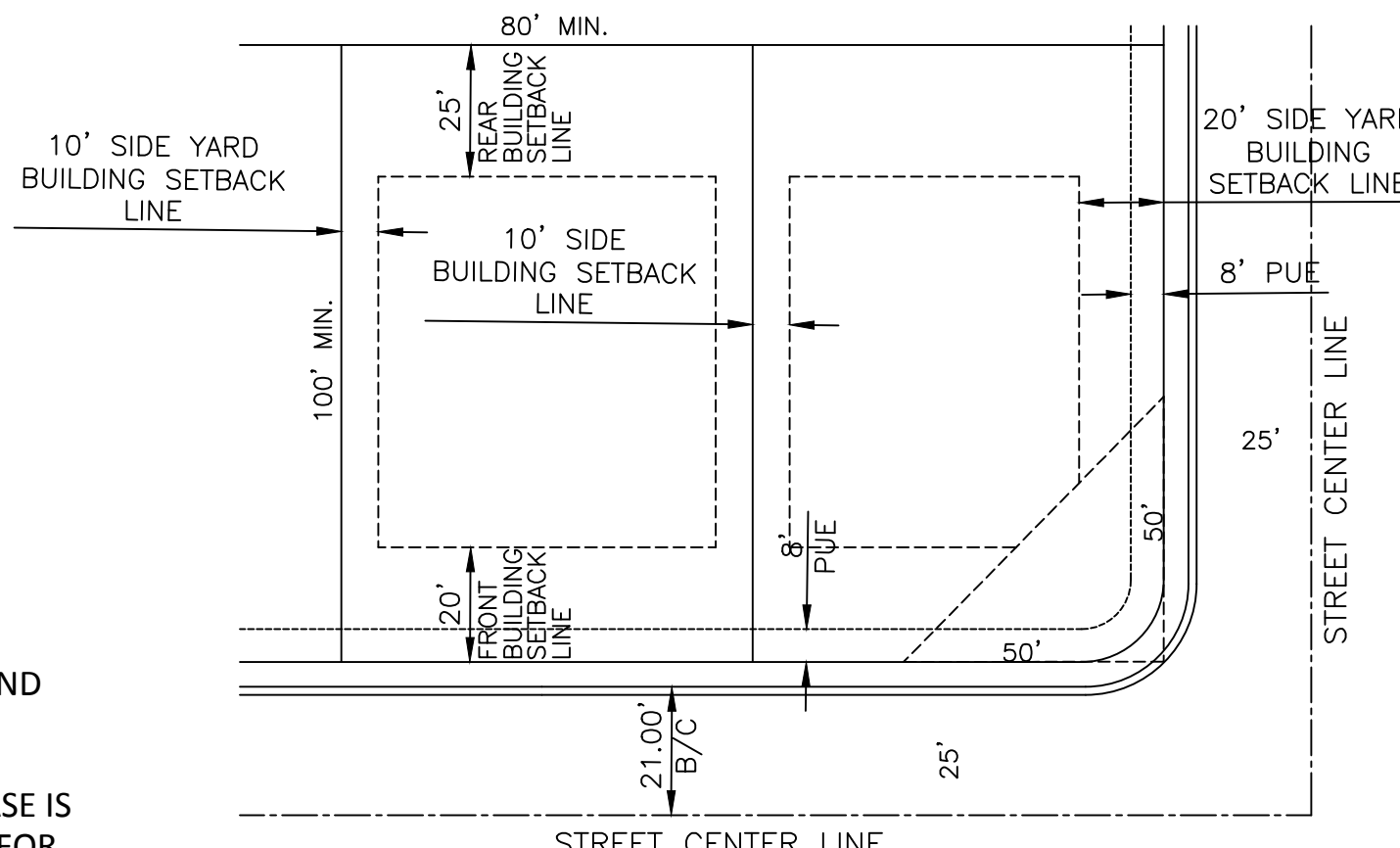

TYPICAL LOT SETBACK DETAIL

**PROJECT DATA**

APN ..... 106-01-163B  
 ..... 106-01-165C  
 CURRENT ZONING ..... R-2  
 OVERALL PARCEL GROSS AREA (ACRES).. 62.44 ACRES  
 PHASE 1 GROSS AREA (ACRES) ..... 10.73 ACRES

**LEGAL DESCRIPTION**

A PORTION OF THE SOUTHEAST QUARTER OF THE NORTHEAST QUARTER OF SECTION 27 AND A PORTION OF THE SOUTH HALF OF THE SOUTHWEST QUARTER OF THE NORTHWEST QUARTER OF SECTION 26 AND A PORTION OF THE NORTH HALF OF THE NORTHWEST QUARTER OF SECTION 26, TOWNSHIP 7 SOUTH, RANGE 25 EAST OF THE GILA AND SALT RIVER BASE AND MERIDIAN, GRAHAM COUNTY, ARIZONA, MORE PARTICULARLY DESCRIBED AS FOLLOWS:

BEGINNING AT THE NORTHWEST CORNER OF THE SOUTHEAST QUARTER OF THE NORTHEAST QUARTER OF SECTION 27, TOWNSHIP 7 SOUTH, RANGE 25 EAST OF THE GILA AND SALT RIVER BASE AND MERIDIAN, GRAHAM COUNTY, ARIZONA;

THENCE NORTH 89° 46' 00" EAST, 1316.74 FEET, ALONG THE NORTH 1/16 LINE TO THE EAST SECTION LINE OF SAID SECTION 27;  
 THENCE SOUTH 00° 13' 54" WEST, 699.46 FEET;  
 THENCE SOUTH 89° 57' 46" EAST, 1310.86 FEET;  
 THENCE SOUTH 00° 17' 54" WEST, 622.29 FEET;  
 THENCE SOUTH 00° 18' 11" WEST, 347.71 FEET;  
 THENCE NORTH 89° 57' 46" WEST, 419.40 FEET;  
 THENCE NORTH 33° 48' 10" WEST, 418.30 FEET;  
 THENCE NORTH 89° 59' 11" WEST, 656.18 FEET;  
 THENCE SOUTH 89° 49' 28" WEST, 1315.59 FEET;  
 THENCE NORTH 00° 10' 54" EAST, 1112.95 FEET;  
 THENCE SOUTH 89° 44' 41" EAST, 116.00 FEET;  
 THENCE NORTH 00° 10' 54" EAST, 188.00 FEET;  
 THENCE NORTH 89° 44' 41" WEST, 116.00 FEET TO THE EAST 1/16 LINE OF SAID SECTION 27;  
 THENCE NORTH 00° 10' 54" EAST, 20.00 FEET TO THE POINT OF BEGINNING.

CONTAINING AN AREA OF 62.44 ACRES, MORE OR LESS.

**INFRASTRUCTURE FINANCING STATEMENT**

THE DEVELOPMENT INFRASTRUCTURE FINANCING HAS BEEN PRE-DETERMINED, APPROVED AND COMMITTED FOR PHASE 1 AS NOTED ON THIS PRELIMINARY PLAT. COMMITMENT FOR THE BALANCE OF THE DEVELOPMENT HAS BEEN PLEDGED BASED UPON ABSORPTION.

**SHEET INDEX**

- 1 COVER SHEET
- 2 PRELIMINARY PLAT
- 3 PARCEL TIE TO SECTIONS

**APPROVAL:**

THIS PLAT HAS BEEN CHECKED FOR COMPLIANCE TO THE APPROVED PRELIMINARY PLAT AND ANY SPECIAL CONDITIONS, AND TO THE REQUIREMENTS OF THE PLANNING ORDINANCE, AND ANY OTHER APPLICABLE REGULATIONS AND APPEAR TO COMPLY WITH ALL REQUIREMENTS WITHIN MY JURISDICTION TO CHECK AND EVALUATE.

TOWN ENGINEER / COMMUNITY DEVELOPMENT DIRECTOR \_\_\_\_\_ DATE \_\_\_\_\_

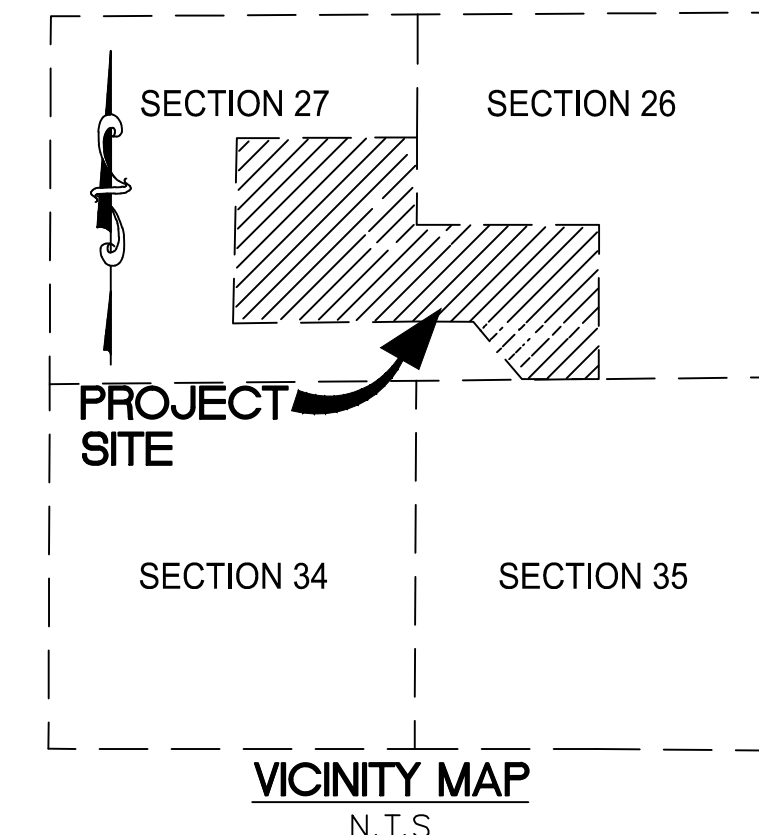

**DEVELOPER/OWNER'S REPRESENTATIVE**

DALEY PROPERTIES, L.L.C.  
 3971 W. FULLER STREET  
 THATCHER, AZ 85552  
 (928) 651-6809

**ENGINEER**

SKG ENTERPRISES, INC.  
 9260 E. RAINTREE DRIVE, SUITE 140  
 SCOTTSDALE, AZ 85260  
 PHONE: (480) 998-5600  
 ATTN: MR. SHAKIR GUSHGARI, PE

**LANDSCAPE ARCHITECT**

THOMAS-CROWLEY  
 PHONE (480) 289-0212  
 ATTN: MR. PAUL THOMAS

**SURVEYOR**

RS TEAM LAND SURVEYORS, LLC  
 P.O. BOX 73487  
 PHOENIX, AZ 85050  
 PHONE: (602) 689-6524  
 ATTN: MR. RICHARD TABOR, RLS

**BENCHMARK**

NGS BENCH MARK DISC STAMPED "L 439 1979" WITH ELEVATION = 2892.46 (NAVD 88 VERTICAL DATUM, NGS PID - CY0730).

NGS CAP LOCATE AT THE NORTH OF THE HIGHWAY ALONG A FENCE-LINE TO THE SOUTH OF GRAHAM COUNTY UTILITIES SUBSTATION LOCATED AT 4544 US HIGHWAY 70, THACHER, ARIZONA 85552.

**BASIS OF BEARING**

THE WEST LINE OF SECTION 26, TOWNSHIP 7 SOUTH, RANGE 25 EAST, G&SRB&M, GRAHAM COUNTY, ARIZONA, BEARING NORTH 00° 14' 25" EAST BETWEEN THE FOUND 16TH CORNER, MONUMENTED BY A 3-INCH BRASS CAP, AND THE FOUND NORTHWEST CORNER OF SAID SECTION 26, MONUMENTED BY A 3-INCH BRASS CAP.

**UTILITIES/SERVICE PROVIDERS**

- WATER :CITY OF SAFFORD
- ELECTRIC :TOWN OF THATCHER / GRAHAM COUNTY COOP.
- TELEPHONE :CENTURY LINK
- SEWER :TOWN OF THATCHER
- CABLE :COX COMMUNICATIONS
- GAS :GRAHAM COUNTY COOP.
- POLICE :TOWN OF THATCHER
- FIRE :TOWN OF THATCHER

P.O. BOX 73487  
 PHOENIX, ARIZONA 85050  
 PHONE: 623-445-2003

**RS Team**  
 Land Surveyors

EXPIRES 9-30-19

PRELIMINARY PLAT  
**DALEY HEIGHTS**  
 SOUTHEAST CORNER OF VALLEY VIEW AND FRYE CREEK ROADS  
 TOWN OF THATCHER, ARIZONA

job no.	225-1
design	SG
approved	RT
date	10-2017



sheet  
 1 of 3

DALEY HEIGHTS

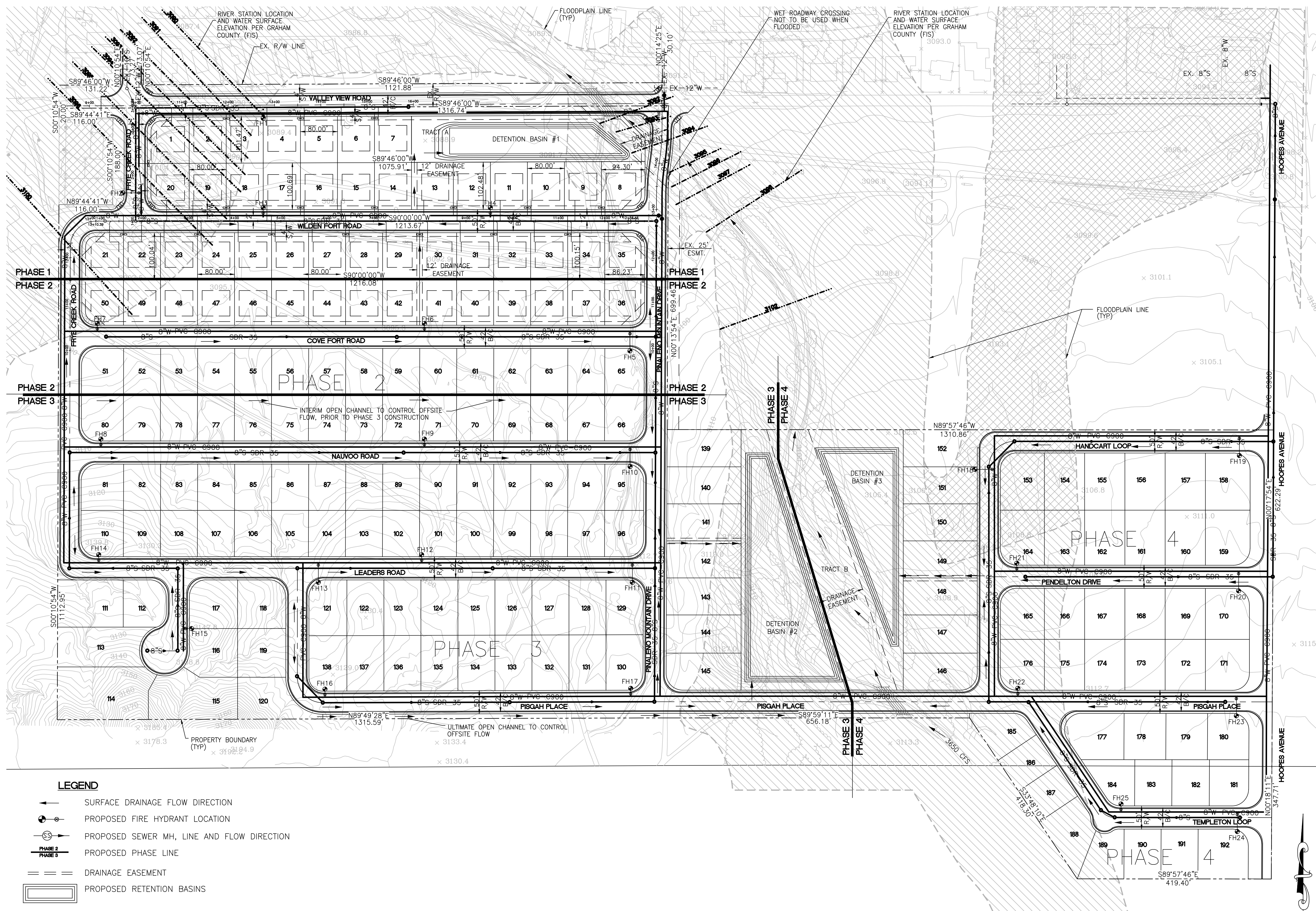

- LEGEND**
- > SURFACE DRAINAGE FLOW DIRECTION
  - PROPOSED FIRE HYDRANT LOCATION
  - (S)— PROPOSED SEWER MH, LINE AND FLOW DIRECTION
  - (P)— PROPOSED PHASE LINE
  - == DRAINAGE EASEMENT
  - ▭ PROPOSED RETENTION BASINS

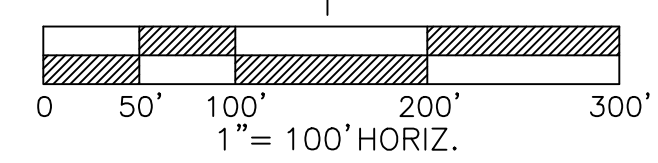

P.O. BOX 73487  
 PHOENIX, ARIZONA 85005  
 PHONE: 623-445-2003

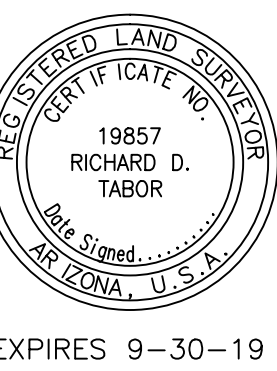
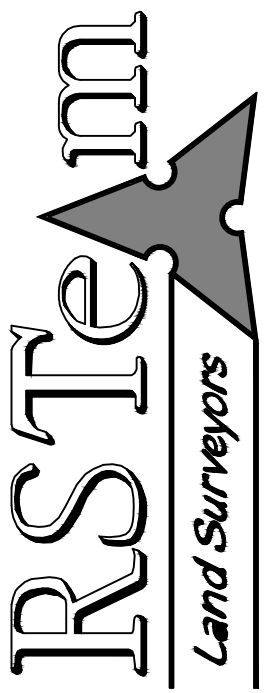

PRELIMINARY PLAT  
**DALEY HEIGHTS**  
 TOWN OF THATCHER, ARIZONA

job no. 225-1  
 design SG  
 approved RT  
 date 10-2017

sheet  
 2 of 3

DALEY HEIGHTS





17 AUG 31 Licr. Dept PM 3:11

State of Arizona
Department of Liquor Licenses and Control
800 W. Washington 5th Floor
Phoenix, AZ 85007
(602) 542-5141

DLLC USE ONLY
Date Processed: 9/8/17
CSR: [Signature]
60th Day: 11/9/17

APPLICATION FOR AGENT CHANGE - ACQUISITION OF CONTROL - RESTRUCTURE

NOTE: 1) The fee for an agent change MUST be submitted with this application: \$100.00 for the first application and \$50.00 for each additional application, not to exceed \$1,000.00. (A.R.S. 4-209.H) NOTE 2) the \$100.00 fee for restructure/acquisition of control MUST be submitted with this application. (A.R.S. 4-209.A)

SECTION 1

Check the appropriate boxes

Agent Change Complete Sections 1,2,3,4,5 & 7
Acquisition of Control Complete Sections 1,2, 3 & 7
Restructure Complete Sections 1,2,3,6 & 7

SECTION 2 (COMPLETE THIS SECTION FOR AGENT CHANGE, ACQUISITION OF CONTROL OR RESTRUCTURE)

1. Name: Sprouse Robert Coleman 10053036
2. Owner Name: Western Refining Retail LLC Corp File #: R1954747-6
3. Business Name: Giant Store #632 Email: None
4. Business Location Address: 2211 W. US HWY 70, Thatcher, Graham County, AZ 85552
5. Is the Business located within the incorporated limits of the above City or Town? Yes
6. Does the Business location address have a street address for a City or Town but is actually in the boundaries of another City, Town or Tribal Reservation? No
7. Mailing Address: 1250 W. Washington Street, #101, Tempe, AZ 85281
8. Business Phone: 928-428-3131 Daytime Contact Phone 928-428-3131
9. Does this transaction involve the sale of any portion of the percentage of ownership or corporate stock? Yes
10. Has there been any change of Controlling Persons? Yes

SECTION 3 (COMPLETE THIS SECTION FOR AGENT CHANGE, ACQUISITION OF CONTROL OR RESTRUCTURE)

Each new person listed in section III must submit a questionnaire (form LIC0101) and a Department approved fingerprint card which may be obtained at the Department of Liquor. A Controlling Person already disclosed to the Department is not required to submit a questionnaire.

1. List all Controlling Persons to be disclosed, current and new.

Table with columns: New, Last, First, Middle, Title, Address, City, State, Zip. Rows include Duffy, Carina, Eckard; Meltzer, Brooks, Alan; Wilkerson, Alan, Ray; Whittington, Derek, Lawson.

(ATTACH ADDITIONAL SHEET(S) IF NECESSARY) SEE ATTACHED

2. List stockholders, percentage owners and/or Controlling Members owning 10% or more

Table with columns: New, Last, First, Middle, % Owned, Address, City, State, Zip. Row includes Western Refining Southwest, Inc. with 100% ownership.

(ATTACH ADDITIONAL SHEET(S) IF NECESSARY) SEE ATTACHED

If the ownership is owned by another entity, ATTACH AN OWNERSHIP FLOWCHART SHOWING THE OFFICERS, MEMBERS, CONTROLLING PERSON AND 10% OR MORE OWNERS FOR THE ENTITIES. Attach additional sheets as necessary in order to disclose all persons.



State of Arizona  
 Department of Liquor Licenses and Control  
 800 W. Washington 5<sup>th</sup> Floor  
 Phoenix, AZ 85007  
 (602) 542-5141

DLIC USE ONLY	
Date Processed:	9/8/17
CSR:	W
60 <sup>th</sup> Day:	11/9/17

**APPLICATION FOR AGENT CHANGE – ACQUISITION OF CONTROL – RESTRUCTURE**

NOTE: 1) The fee for an agent change MUST be submitted with this application: \$100.00 for the first application and \$50.00 for each additional application, not to exceed \$1,000.00. (A.R.S. 4-209.H) NOTE 2) the \$100.00 fee for restructure/acquisition of control MUST be submitted with this application. (A.R.S. 4-209.A)

**SECTION 1**

Check the appropriate boxes

<input type="checkbox"/> Agent Change Complete Sections 1,2,3,4,5 & 7	<input checked="" type="checkbox"/> Acquisition of Control Complete Sections 1,2, 3 & 7	<input type="checkbox"/> Restructure Complete Sections 1,2,3,6 & 7
--------------------------------------------------------------------------	--------------------------------------------------------------------------------------------	-----------------------------------------------------------------------

**SECTION 2 (COMPLETE THIS SECTION FOR AGENT CHANGE, ACQUISITION OF CONTROL OR RESTRUCTURE)**

- Name: Sprouse Robert Coleman 10053031  
(EXISTING AGENT OR NEW AGENT) Last First Middle Liquor License #
- Owner Name: Western Refining Retail LLC Corp File #: R1954747-6  
(Exactly as it appears on Liquor License) (If applicable)
- Business Name: Giant Store #654 Email: NONE  
(Exactly as it appears on Liquor License)
- Business Location Address: 3775 W. Main St, Thatcher, Graham County, AZ 85552  
(Do not use P.O. Box Number) City COUNTY Zip
- Is the Business located within the incorporated limits of the above City or Town?  Yes  No
- Does the Business location address have a street address for a City or Town but is actually in the boundaries of another City, Town or Tribal Reservation?  Yes  No If Yes, what City, Town or Tribal Reservation is this Business located in: N/A
- Mailing Address: 1250 W. Washington Street, #101, Tempe, AZ 85281  
City State Zip
- Business Phone: 928-428-3280 Daytime Contact Phone 928-428-3280
- Does this transaction involve the sale of any portion of the percentage of ownership or corporate stock?  Yes  No If yes, submit a certified copy of minutes.
- Has there been any change of Controlling Persons?  Yes  No if yes, submit a copy of the minutes, amended articles of organization and/or amended operating agreement showing change

**SECTION 3 (COMPLETE THIS SECTION FOR AGENT CHANGE, ACQUISITION OF CONTROL OR RESTRUCTURE)**

Each new person listed in section III must submit a questionnaire (form LIC0101) and a Department approved fingerprint card which may be obtained at the Department of Liquor. A Controlling Person already disclosed to the Department is not required to submit a questionnaire.

1. List all Controlling Persons to be disclosed, current and new.

New	Last	First	Middle	Title	Address	City	State	Zip
<input checked="" type="checkbox"/>	Duffy, Carina, Eckard			Dir/Pres	212 Fleetwood Drive, San Antonio, TX 78232			
<input checked="" type="checkbox"/>	Meltzer, Brooks, Alan			Dir/Secy	13 Camden Oaks, San Antonio, TX 78248			
<input checked="" type="checkbox"/>	Wilkerson, Alan, Ray			Dir/VP	14 Stone Hill Court, San Antonio, TX 78258			
<input checked="" type="checkbox"/>	Whittington, Derek, Lawson			Treasurer	2034 Oak Dew, San Antonio, TX 78232			

(ATTACH ADDITIONAL SHEET(S) IF NECESSARY) SEE ATTACHED

2. List stockholders, percentage owners and/or Controlling Members owning 10% or more

New	Last	First	Middle	% Owned	Address	City	State	Zip
<input type="checkbox"/>	Western Refining Southwest, Inc.			100%	1250 W. Washington Street, #101, Tempe, AZ 85281			
<input type="checkbox"/>								
<input type="checkbox"/>								
<input type="checkbox"/>								

(ATTACH ADDITIONAL SHEET(S) IF NECESSARY) SEE ATTACHED

If the ownership is owned by another entity, ATTACH AN OWNERSHIP FLOWCHART SHOWING THE OFFICERS, MEMBERS, CONTROLLING PERSON AND 10% OR MORE OWNERS FOR THE ENTITIES. Attach additional sheets as necessary in order to disclose all persons.



State of Arizona
Department of Liquor Licenses and Control
800 W. Washington 5th Floor
Phoenix, AZ 85007
(602) 542-5141

DLIC USE ONLY
Date Processed: 9/8/17
CSR: W
60th Day: 11/7/17

APPLICATION FOR AGENT CHANGE - ACQUISITION OF CONTROL - RESTRUCTURE

NOTE: 1) The fee for an agent change MUST be submitted with this application: \$100.00 for the first application and \$50.00 for each additional application, not to exceed \$1,000.00. (A.R.S. 4-209.H) NOTE 2) the \$100.00 fee for restructure/acquisition of control MUST be submitted with this application. (A.R.S. 4-209.A)

SECTION 1
Check the appropriate boxes

Agent Change Complete Sections 1,2,3,4,5 & 7
Acquisition of Control Complete Sections 1,2, 3 & 7
Restructure Complete Sections 1,2,3,6 & 7

SECTION 2 (COMPLETE THIS SECTION FOR AGENT CHANGE, ACQUISITION OF CONTROL OR RESTRUCTURE)

1. Name: Sprouse Robert Coleman 10053037
2. Owner Name: Western Refining Retail LLC Corp File #: R1954747-6
3. Business Name: Giant Store #902 Email: NONE
4. Business Location Address: 2946 W. HWY 70, Thatcher, Graham County, AZ 85552
5. Is the Business located within the incorporated limits of the above City or Town? Yes No
6. Does the Business location address have a street address for a City or Town but is actually in the boundaries of another City, Town or Tribal Reservation? Yes No
7. Mailing Address: 1250 W. Washington Street, #101, Tempe, AZ 85281
8. Business Phone: 928-428-2553 Daytime Contact Phone 928-428-2553
9. Does this transaction involve the sale of any portion of the percentage of ownership or corporate stock? Yes No
10. Has there been any change of Controlling Persons? Yes No

SECTION 3 (COMPLETE THIS SECTION FOR AGENT CHANGE, ACQUISITION OF CONTROL OR RESTRUCTURE)

Each new person listed in section III must submit a questionnaire (form LIC0101) and a Department approved fingerprint card which may be obtained at the Department of Liquor. A Controlling Person already disclosed to the Department is not required to submit a questionnaire.

1. List all Controlling Persons to be disclosed, current and new.

Table with columns: New, Last, First, Middle, Title, Address, City, State, Zip. Rows include Duffy, Carina, Eckard; Meltzer, Brooks, Alan; Wilkerson, Alan, Ray; Whittington, Derek, Lawson.

(ATTACH ADDITIONAL SHEET(S) IF NECESSARY) SEE ATTACHED

2. List stockholders, percentage owners and/or Controlling Members owning 10% or more

Table with columns: New, Last, First, Middle, % Owned, Address, City, State, Zip. Row includes Western Refining Southwest, Inc. with 100% ownership.

(ATTACH ADDITIONAL SHEET(S) IF NECESSARY) SEE ATTACHED

If the ownership is owned by another entity, ATTACH AN OWNERSHIP FLOWCHART SHOWING THE OFFICERS, MEMBERS, CONTROLLING PERSON AND 10% OR MORE OWNERS FOR THE ENTITIES. Attach additional sheets as necessary in order to disclose all persons.

**NOTICE OF MEETING OF THE  
THATCHER TOWN COUNCIL  
September 18, 2017**

Councilmember's present: Mayor Rivera, Vice Mayor Allen, Councilman Griffin, Councilman Rapier, Councilman Larson, Councilman Bryce, Councilman Welker

Staff present: Town Manager Terry Hinton, Town Engineer Heath Brown, Police Chief Shaffen Woods, Town Attorney Matt Clifford, Fire Chief Mike Payne, Deputy Clerk Michelle Mortensen

Visitors: Horatio Skeet, Brooke Curley

**AGENDA**

1. Welcome and Call Meeting to Order by Mayor Rivera at 6:00 p.m. He stated we do have a quorum and on behalf of this council, God bless our men and women in the armed forces around the world, our first responders, and our police and fire.

2. Pledge of Allegiance led by Horatio Skeet.

3. **CONSENT AGENDA:**

- A. Approve minutes of the August 28, 2017 Regular Council Meeting and the September 11, 2017 Work Session.
- B. Planning and Zoning Monthly Report.
- C. Police Monthly Report.
- D. Approval of Invoices.
- E. Financial Reports.

Councilman Larson made the motion to approve the consent agenda and was seconded by Vice Mayor Allen. Motion carries unanimously.

4. **NEW BUSINESS:**

5. A. Safford Water Rate Study – Horatio Skeet
- City Manger Skeet stated on behalf of City of Safford City Council and staff we are reflecting on the agreement that we have to provide water with the Town. A rate study has been provided by K.R. Saline and Associates. With concurrence of your Town Manger, we did this study to review and see if any changed needed to be made. Town of Thatcher pays 10% over and above the rates of our City residents. One of the things I looked at is equalizing the rates among everyone. The 10% brings in about \$115-120 thousand dollars. Mr. Hinton and I got to talking about some options and one of those was to put a certain percentage of sales tax towards the capital infrastructure needs of the water system and then we could control and manage the increases. The first proposal would be to charge a 5% rate increase now and in the year 2020 another 15%. The second proposal is one where the City of Safford and Town of Thatcher put two tenths of sales tax towards the infrastructure. That would be about \$175,000 from Thatcher and \$325,000 from Safford to go towards capital infrastructure. This would make the rate increase 5% now and in

2021 6%. If we consider the option of pledging the two tenths from Thatcher and Safford that amount would always be available for capital projects. The amount of the capital improvements needed over the next five years is \$20,000,000. There is enough need to go beyond the \$20,000,000 but this should take care of the ones that are the most critical. I envision entering into an IGA between the two cities and the funds would be segregated in the water department and during the five year period both staffs would meet to make sure the needs are being met. These would be for the main six and eight inch lines that bring distribution.

If you give your approval then I will take this to my city council. Mayor Rivera asked if an MOU can be taken away. Mr. Skeet said anything is possible but in a legal IGA where the funds would be pledged towards a capital improvement it would be pretty difficult to undo. Councilman Rapier stated that we are getting to ready to spend a lot of capital on Church Street. We see City of Safford doing a lot of work there, is that something that they can stop? The next question is if we enter into this agreement that Church Street is a part of this. Mr. Hinton stated they are still going to get the money whether you approve this or disapprove this; the only question is how it will be funded. Vice Mayor Allen asked about two tenths. Let's say we have a really good year then will it take more? Mr. Skeet answered yes. Vice Mayor Allen then asked if \$175,000 suffices that then why don't we do that. Mr. Skeet answered if you have a killer year then that brings a lower rate to the customers. Mr. Rapier asked if the County would still be paying at a higher rate, and the answer was yes by Mr. Skeet. We offered them the same option but they did not want to proceed with this proposal. Councilman Griffin asked we are talking about adding arterial lines, the concern would be would we put that into an unincorporated area. Mr. Skeet said that is why we would charge the 25% to county residents to offset this. Mr. Hinton stated that we could make whatever provisions we need to be able to review the percentages if needed. Rivera stated that he thinks the council would like you to continue to work on this.

B. Diamond Springs infrastructure acceptance.

Mr. Hinton stated that Diamond Springs infrastructure has been in place and I am recommending that we accept the infrastructure into our system and Mr. Brown agreed. Councilman Griffin asked what about the road where there is only half of a street, how do we deal with that in the future? Mr. Hinton answered that if they decide to build later then that will have to be completed then. Councilman Rapier made the motion to approve the Diamond Springs infrastructure and was seconded by Vice Mayor Allen. Motion carries unanimously.

C. Bid award for Fire Department roof.

Mr. Hinton stated that when we had those major storms it damaged the roof. There are three bids. Staff would recommend accepting the bid from Woodside Construction for \$32,940 which was the low bid. Councilman Rapier made the motion to approve the bid by Woodside Construction for \$32,940 and was seconded by Councilman Bryce. Motion carries unanimously.

**10. INFORMATIONAL ITEMS:**

A. Town Manager's Report:

Mr. Hinton stated that the brush truck is almost complete. All the issues with that have been resolved and we have a commitment from the fire district to pay for part of

that. The new fire truck is just about complete. Mr. Payne and someone else will go out there to look at the truck and drive it and make sure everything is alright. The shade structure is up at the Daley Estates Park and they are working on the sidewalk and curb around it in preparation for the rubber tiles. We will be moving back to Hoopes Avenue in about two weeks. I requested the plans and the O&M on the FMI rec center. Councilman Rapier stated that Sean Wenham was pretty sure that he was going to be able to get that information. CSHQA is working up on a more detailed concept for the sports complex. Heath and I also talked about making an amphitheatre in that low lying area. That was one of the ideas we had to utilize that space. We are also looking into the game and fish grants and asking lots of questions. We hope to get an application in by the end of the October.

We have an opening on the board of adjustments which is by appointment on the Mayor. We need to look at getting that filled. Councilman Rapier stated that in his conversation with Sean Wenham, the hospital did a perception study where PRC reached out to residents to ask for their opinions. Based on what we discussed earlier this month, I am wondering if we could get this company to do the same thing to see what our community wants, and is willing to do, to make the project come to pass. Sean suggested that the United Way would probably fund this. Councilman Bryce stated that he thinks we need to do that because of the interest that the lake has brought after being in the paper. Mayor Rivera stated he had talked to Mr. Hinton earlier, when we built the appreciation monument, part of the project was to include putting a kiosk and a table with book to see all those who worked for the Town, police, and fire departments, as well as putting our cemetery information online. We need to finish that project.

B. Fire Department Report.

Mr. Payne stated that twelve of us went to fire school and we will be applying the things we learned at our meetings the next few months. Tuesday night we will be doing a preplan of the Empire building. October 10 will be our open house. One of the speakers at fire school talked about cancer in firefighters. 78% of firefighters who do that as a career get cancer. They are trying to design turnouts to be more protective to protect them from carcinogens. Mayor Rivera asked about the percentage of volunteers that do, and Mr. Payne responded that they are going to start tracking that.

C. Police Department Report.

Chief Woods stated that we had training last week out at the range. We have worked out an agreement with other departments to help cover calls during training. We did some officer and citizen training drills in the dark as well as some handgun training. Ginn & Edwards came down and gave our law and legal updates.

**11. COMMITTEE REPORTS:**

A. Safe House

Councilman Bryce stated there was nothing to report.

B. Chamber of Commerce

Councilman Rapier stated there was nothing to report.

C. SEAGO

Mayor Rivera also had nothing to report.

**12. ADJOURNMENT**

Motion was made by Councilman Rapier and was seconded by Vice Mayor Allen at 7:13 to adjourn the meeting. Motion carries unanimously.

**APPROVED:**

\_\_\_\_\_  
Michelle Mortensen, Deputy Clerk

\_\_\_\_\_  
Robert Rivera, Mayor

**CERTIFICATION**

I hereby certify that the foregoing minutes are a true and correct copy of the minutes of the regular/special meeting of the Town Council of the Town of Thatcher held on this 18th day of January 2016. I further certify that the meeting was duly called and held and that a quorum was present.

\_\_\_\_\_  
Michelle Mortensen, Deputy Clerk

## TOWN OF THATCHER BUILDING PERMITS

				Sep-17			
					<b>Number of Permits</b>	<b>Valuation</b>	<b>Number of housing Units</b>
<b>New Residential Buildings</b>							
One-family houses, detached					2	320,000	2
one-family houses, attached							
Two-family buildings							
Apartment Three and four family							
Buildings Five or more family							
Manufactured/Mobile Homes/Park Models					1	22,000	1
Publicly owned housing units							
Hotels, motels, tourist courts and cabins							
Other shelter							
<b>New Nonresidential Buildings</b>							
Amusement and recreational buildings							
Churches and other religious buildings							
Industrial buildings							
Parking garages open to general public							
Service Stations and Repair Garages							
Hospitals and other institutional buildings							
Office, bank and professional buildings							
Stores and other mercantile buildings							
Public works and utilities buildings, publicly owned							
Public works and utilities buildings, privately owned							
Schools/other educational buildings, publicly owned							
Schools/other educational buildings, privately owned							
Other nonresidential buildings							
Structures other than buildings							
Swimming pools, fences, billboards, signs, awnings, etc.					1	40,000	
<b>Additions and Alterations</b>							
Residential buildings							
Residential garages and carports							
Commercial buildings							
All other buildings and structures					1	18,000	
<b>Total</b>							
Housing unit demolitions							
<b>TOTAL</b>					<b>5</b>	<b>400,000</b>	



## POLICE DEPARTMENT ACTIVITY REPORT 2017

### MONTHLY ACTIVITY & MILEAGE

NAME	CA	A	JR	TC	W	TOT	Miles	Car #	Mileage	Hrs	Cont/H
Cauthen, Everett	38	0	1	10	97	146	1316	203	83931	200	0.73
Maner, JR	12	5	1	2	27	47	381	P206	75742	156	0.30
Ellsworth, Brian	16	3	0	5	20	44	460	207	21691	140	0.32
West, Kevin	36	0	1	17	29	83	1000	P203	66007	184	0.45
Larson, Jason	31	1	1	6	31	70	667	P207	34452	147	0.48
Rodger, Andy	19	1	0	15	72	107	966	213	30668	170	0.63
Whisman, James	11	0	0	4	17	32	975	P209	44375	134	0.24
Williams, Rebecca	<u>50</u>	<u>6</u>	<u>0</u>	<u>1</u>	<u>10</u>	67	<u>701</u>	2015	25654	<u>146</u>	<u>0.46</u>
<b>TOTAL</b>	213	16	4	60	303	596	6466			1276	0.47

### YTD

YTD ACTIVITY	Jan	Feb	Mar	Apr	May	Jun	Jul	Aug	Sep	Oct	Nov	Dec	Total	Avg.	Hours	Cont/H
<b>NAME</b>																
Cauthen, Everett	98	129	135	92	108	138	110	91	146				1047	116	1795	0.58
Maner, JR	80	96	91	88	74	107	89	75	47				747	83	1667	0.45
Ellsworth, Brian	103	51	84	58	46	55	36	40	44				517	57	1534	0.34
West, Kevin	63	58	58	48	66	55	22	47	83				500	56	1451	0.34
Larson, Jason	67	80	101	74	56	52	51	59	70				610	68	1347	0.45
Rodger, Andy	91	61	89	71	75	49	57	32	107				632	70	1522	0.42
Whisman, James	86	50	46	12	17	35	36	32	32				346	38	1399	0.25
Williams, Rebecca	<u>73</u>	<u>45</u>	<u>33</u>	<u>72</u>	<u>46</u>	<u>47</u>	<u>50</u>	<u>29</u>	<u>67</u>				<u>462</u>	<u>51</u>	<u>1392</u>	<u>0.33</u>
<b>TOTAL</b>	661	570	637	515	488	538	451	405	596	0	0	0	4861	405	12106	0.40

YTD MILEAGE	Jan	Feb	Mar	Apr	May	Jun	Jul	Aug	Sep	Oct	Nov	Dec	Total	Avg.
<b>NAME</b>														
Cauthen, Everett	1731	1436	1343	1034	1632	1739	816	1019	1316				12066	1341
Maner, JR	913	1006	1177	992	903	1663	934	994	381				8963	996
Ellsworth, Brian	967	885	933	647	927	978	666	593	460				7056	784
West, Kevin	803	747	1063	918	958	712	703	1134	1000				8038	893
Larson, Jason	326	775	629	910	802	769	655	830	667				6363	707
Rodger, Andy	1271	756	828	1870	1314		1155	819	966				8979	1122
Whisman, James	1040	643	717	386	514		1121	1079	975				6475	809
Williams, Rebecca	<u>1085</u>	<u>566</u>	<u>592</u>	<u>644</u>	<u>767</u>	<u>849</u>	<u>573</u>	<u>620</u>	<u>701</u>				<u>6397</u>	<u>711</u>
<b>TOTAL</b>	8136	6814	7282	7401	7817	6710	6623	7088	6466	0	0	0	64337	5361

TC/W RATIO	Jan		Feb		Mar		Apr		May		Jun		Jul		Aug		Sept		Oct		Nov		Dec		YTD TOTAL		YTD AVG.			
	TC	W	TC	W	TC	W	TC	W	TC	W	TC	W	TC	W	TC	W	TC	W	TC	W	TC	W	TC	W	TC	W	TC	W		
Cauthen, Everett	0	61	11	85	8	90	2	58	4	66	4	64	2	50	3	48	10	97									44	619	5	69
Hopson, James	4	42	7	46	4	60	8	46	2	37	8	56	8	38	7	30	2	27									50	382	6	42
Ellsworth, Brian	6	49	4	21	10	28	3	14	8	12	4	16	3	9	4	14	5	20									47	183	5	20
West, Kevin	4	23	4	14	1	28	3	16	1	21	1	7	0	3	4	18	17	29									35	159	4	18
Larson, Jason	0	7	4	51	9	65	12	23	0	39	4	26	6	21	2	30	6	31									43	293	5	33
Rodger, Andy	1	59	2	44	4	56	1	44	6	44	0	34	1	34	0	15	15	72									30	402	3	45
Whisman, James	0	48	2	14	0	18	0	0	0	1	3	5	0	6	1	5	4	17									10	114	1	13
Williams, Rebecca	<u>4</u>	<u>12</u>	<u>3</u>	<u>2</u>	<u>1</u>	<u>10</u>	<u>5</u>	<u>27</u>	<u>2</u>	<u>13</u>	<u>2</u>	<u>8</u>	<u>0</u>	<u>10</u>	<u>1</u>	<u>3</u>	<u>1</u>	<u>10</u>									<u>19</u>	<u>95</u>	<u>2</u>	<u>11</u>
<b>TOTAL</b>	19	301	37	277	37	355	34	228	23	233	26	216	20	171	22	163	60	303	0	0	0	0	0	0	0	0	278	2247	22.24	179.76

### Monthly Activity Average

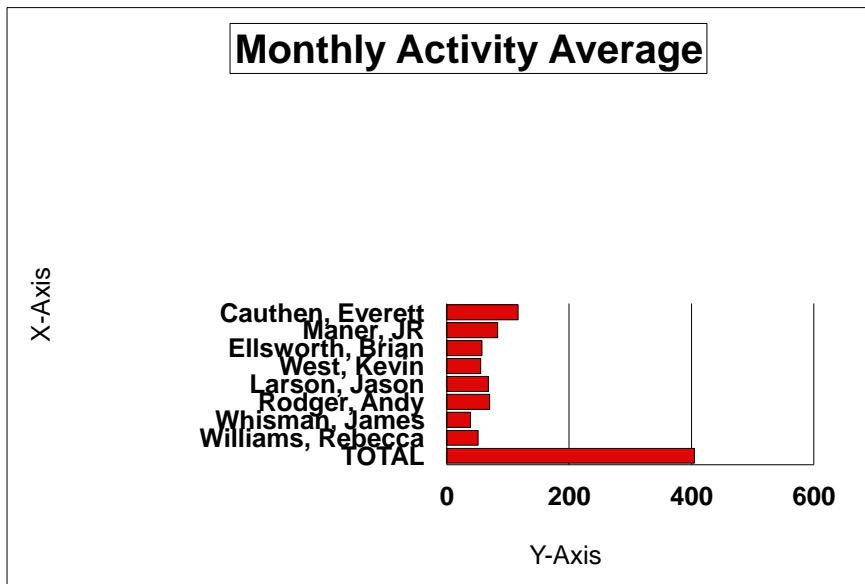

Thatcher Police Department Chief's Report  
2016

	JAN	FEB	MAR	APR	MAY	JUNE	JULY	AUG	SEP	OCT	NOV	DEC	TOTAL
Complaints Answered	195	181	206	209	221	185	188	229	225	213	196	205	2248
Arrests	20	19	21	20	23	13	27	22	35	19	14	11	733
Juvenile Referrals	3	7	7	3	2	2	2	3	5	7	0	2	41
Traffic Citations	37	37	30	22	35	34	27	50	33	51	40	36	396
Warnings	157	192	217	154	185	238	183	213	202	285	239	263	2265
MONTHLY TOTAL	412	436	481	408	466	472	427	517	500	575	489	517	5700
YEARLY TOTAL	412	848	1329	1737	2203	2675	3102	3619	4119	4694	5183	5700	5700

CURRENT MONTH BREAKDOWN

COMPLAINT BREAKDOWN

						<u>Property</u>	<u>MILES</u>
Accidents	17	Sex Offenses	0	Thefts	11	Stolen	\$ 4650 9442
Traffic Comp	7	Crim Damage	5	Disturbance	2	Recovered	3700
Veh Assist	17	Alarm	22	Fire	7	Difference	950
Domestic	2	Assault	0	Deaths	0		
DUI	5	Animal	5	Juv Comp	2		
Missing Person	0	Drugs	3	Gen Comp	109		
Alcohol Viol	2	Homicide	0				

YEAR TO DATE BREAKDOWN

COMPLAINT BREAKDOWN

						<u>Property</u>	<u>MILES</u>
Accidents	166	Sex Offenses	6	Thefts	166	Stolen	\$ 70145 106595
Traffic Comp	106	Crim Damage	75	Disturbance	31	Recovered	9524
Veh Assist	172	Alarm	189	Fire	44	Difference	60621
Domestic	66	Assault	13	Deaths	5		
DUI	36	Animal	87	Juv Comp	35		
Missing Person	10	Drugs	63	Gen Comp	1374		
Alcohol Viol	13	Homicide	0				

Thatcher Police Department Chief's Report  
2017

	JAN	FEB	MAR	APR	MAY	JUNE	JULY	AUG	SEP	OCT	NOV	DEC	TOTAL
Complaints Answered	326	237	228	230	218	277	235	201	213				2165
Arrests	13	20	19	18	12	19	25	18	16				160
Juvenile Referrals	2	0	2	8	2	1	0	3	4				22
Traffic Citations	19	37	37	34	23	26	20	22	60				278
Warnings	301	277	355	228	233	216	171	163	303				2247
MONTHLY TOTAL	661	571	641	518	488	539	451	407	536				4812
YEARLY TOTAL	661	1232	1873	2391	2879	3418	3869	4276	4812				4812

CURRENT MONTH BREAKDOWN

COMPLAINT BREAKDOWN

						<u>Property</u>	<u>MILES</u>
Accidents	9	Sex Offenses	1	Thefts	12	Stolen	\$ 1094 7449
Traffic Comp	5	Crim Damage	6	Disturbance	2	Recovered	0
Veh Assist	22	Alarm	15	Fire	5	Difference	1094
Domestic	1	Assault	4	Deaths	0		
DUI	2	Animal	6	Juv Comp	4		
Missing Person	0	Drugs	3	Gen Comp	134		
Alcohol Viol	0	Homicide	0				

YEAR TO DATE BREAKDOWN

COMPLAINT BREAKDOWN

						<u>Property</u>	<u>MILES</u>
Accidents	101	Sex Offenses	9	Thefts	89	Stolen	\$ 18572 73285
Traffic Comp	72	Crim Damage	36	Disturbance	19	Recovered	1132
Veh Assist	150	Alarm	136	Fire	34	Difference	17440
Domestic	51	Assault	13	Deaths	7		
DUI	19	Animal	129	Juv Comp	33		
Missing Person	8	Drugs	28	Gen Comp	1340		
Alcohol Viol	3	Homicide	0				

## Report Criteria:

Detail report.  
Invoices with totals above \$0.00 included.  
Only paid invoices included.

Vendor	Vendor Name	Invoice Number	Description	Invoice Date	Net Invoice Amount	Amount Paid	Date Paid
<b>03-20300</b>							
1351	AMERICAN GENERAL LIFE CO	CA0853/08251	ACCIDENT INS	08/25/2017	1,114.03	1,114.03	09/06/2017
3524	DELTA DENTAL OF ARIZONA	589676	DENTAL INS	09/15/2017	4,398.28	4,398.28	09/28/2017
Total 03-20300:					5,512.31	5,512.31	
<b>03-20380</b>							
1230	AFLAC	201637	INSURANCE PREMIUMS	09/15/2017	1,535.70	1,535.70	09/21/2017
Total 03-20380:					1,535.70	1,535.70	
<b>10-20300</b>							
8200	VISION SERVICE PLAN	SEPT-OCTOB	VISION PLAN/121448340001	09/01/2017	549.64	549.64	09/28/2017
Total 10-20300:					549.64	549.64	
<b>10-20320</b>							
1960	ARIZONA STATE TREASURER	AUG2017	COLLECTED FUNDS	09/07/2017	5,364.85	5,364.85	09/13/2017
10012	BRYAN MURPHY	CR2017-097	CASH BOND REFUND	08/31/2017	500.00	500.00	09/06/2017
3521	DENNY'S	CR2017-087	RESTITUTION-J. STEPHENS	09/25/2017	25.00	25.00	09/28/2017
4470	GRAHAM COUNTY SHERIFF'S	AUG2017	DUI HOUSING FEES	09/11/2017	110.00	110.00	09/13/2017
4505	GRAHAM COUNTY TREASURE	AUG2017	Z052 ADDITIONAL ASSESSMEN	09/11/2017	17.25	17.25	09/13/2017
9015	LOUIE TARTAGLIA	CR2016-151/0	RESTITUTION	09/05/2017	50.00	50.00	09/13/2017
Total 10-20320:					6,067.10	6,067.10	
<b>10-50-310</b>							
8050	CENTURY LINK	928428511085	TELEPHONE	08/22/2017	.05	.05	09/13/2017
4364	IMPACT TELECOM	608591142	LONG DISTANCE	09/10/2017	1.97	1.97	09/21/2017
8130	VALLEY TELECOM	33664-002/092	TELEPHONE	09/20/2017	67.27	67.27	09/28/2017
Total 10-50-310:					69.29	69.29	
<b>10-50-311</b>							
2832	CABLE ONE	105245682/091	INTERNET	09/16/2017	212.50	212.50	09/28/2017
7827	TRANSWORLD NETWORK COR	14157808-A9	INTERNET	09/16/2017	21.88	21.88	09/28/2017
7827	TRANSWORLD NETWORK COR	14162692-A10	INTERNET	09/22/2017	11.83	11.83	09/28/2017
8195	VERIZON WIRELESS	9791726905	AIR CARDS/CELL	08/26/2017	375.14	375.14	09/06/2017
Total 10-50-311:					621.35	621.35	
<b>10-50-326</b>							
5667	MATT N. CLIFFORD, P.C.	SEPT2017	ATTORNEY	09/05/2017	3,417.00	3,417.00	09/06/2017
Total 10-50-326:					3,417.00	3,417.00	
<b>10-50-344</b>							
3850	EASTERN ARIZONA COURIER	1708000630	PRINTING & ADVERTISING	08/31/2017	27.89	27.89	09/13/2017
3850	EASTERN ARIZONA COURIER	1708000998	PRINTING & ADVERTISING	08/31/2017	440.33	440.33	09/13/2017
5080	MCMURRAY COMMUNICATIONS	LOCAL SPORT	PRINTING & ADVERTISING	08/31/2017	59.70	59.70	09/13/2017
Total 10-50-344:					527.92	527.92	

Vendor	Vendor Name	Invoice Number	Description	Invoice Date	Net Invoice Amount	Amount Paid	Date Paid
<b>10-50-505</b>							
10120	Arby's	091917	NO KID HUNGRY	09/19/2017	100.00	100.00	09/21/2017
2320	CHASE CARD SERVICES	080117LEAGU	CREDIT	08/01/2017	135.00-	135.00-	09/13/2017
2320	CHASE CARD SERVICES	081617	EVENTBRITE	08/16/2017	27.37	27.37	09/13/2017
2320	CHASE CARD SERVICES	082117EVENT	EVENTBRITE	08/21/2017	27.37	27.37	09/13/2017
2320	CHASE CARD SERVICES	082217LEAGU	HILTON	08/22/2017	3,698.81	3,698.81	09/13/2017
2320	CHASE CARD SERVICES	082517HILTON	HILTON	08/25/2017	11.00	11.00	09/13/2017
6250	PETTY CASH	091217	MANOR HOUSE-ANDY	09/12/2017	2.52	2.52	09/21/2017
6250	PETTY CASH	09122017	MANOR HOUSE	09/12/2017	13.97	13.97	09/21/2017
Total 10-50-505:					3,746.04	3,746.04	
<b>10-50-515</b>							
4490	GILA VALLEY COMMUNITY FOU	2017-18	DONATION	08/29/2017	5,000.00	5,000.00	09/13/2017
Total 10-50-515:					5,000.00	5,000.00	
<b>10-50-590</b>							
2320	CHASE CARD SERVICES	081417	AMAZON	08/14/2017	108.01	108.01	09/13/2017
7855	TROPHIES 'N TEES	19302	HATS	09/15/2017	1,340.62	1,340.62	09/28/2017
Total 10-50-590:					1,448.63	1,448.63	
<b>10-52-310</b>							
8050	CENTURY LINK	928428511085	TELEPHONE	08/22/2017	.35	.35	09/13/2017
4364	IMPACT TELECOM	608591142	LONG DISTANCE	09/10/2017	12.99	12.99	09/21/2017
8130	VALLEY TELECOM	33664-002/092	TELEPHONE	09/20/2017	444.45	444.45	09/28/2017
Total 10-52-310:					457.79	457.79	
<b>10-52-311</b>							
7827	TRANSWORLD NETWORK COR	14157808-A9	INTERNET	09/16/2017	5.42	5.42	09/28/2017
7827	TRANSWORLD NETWORK COR	14162692-A10	INTERNET	09/22/2017	2.93	2.93	09/28/2017
8195	VERIZON WIRELESS	9791726905	AIR CARDS/CELL	08/26/2017	92.98	92.98	09/06/2017
Total 10-52-311:					101.33	101.33	
<b>10-52-312</b>							
4302	CITY OF SAFFORD	15-970.00/0831	EAGLE MEADOW	08/31/2017	44.22	44.22	09/13/2017
4302	CITY OF SAFFORD	16-161.01/0831	TOWN HALL	08/31/2017	364.22	364.22	09/13/2017
4302	CITY OF SAFFORD	17-528.01/0831	FIRE DEPT	08/31/2017	51.77	51.77	09/13/2017
4302	CITY OF SAFFORD	17-529.02/0831	3670 W MAIN	08/31/2017	63.19	63.19	09/13/2017
Total 10-52-312:					523.40	523.40	
<b>10-52-314</b>							
4406	GRAHAM CO UTILITIES	4743-012/0915	TOWN HALL	09/15/2017	59.07	59.07	09/21/2017
4406	GRAHAM CO UTILITIES	4743-018/0915	3670 W MAIN	09/15/2017	37.45	37.45	09/21/2017
Total 10-52-314:					96.52	96.52	
<b>10-52-342</b>							
1335	AMERICAN DYNA-MITE	091817	PEST CONTROL	09/18/2017	60.00	60.00	09/21/2017
1335	AMERICAN DYNA-MITE	4852	PEST CONTROL	08/21/2017	60.00	60.00	09/06/2017
5030	JON'S HEATING AND COOLING	7498	CITY HALL AC	09/12/2017	4,700.00	4,700.00	09/28/2017
Total 10-52-342:					4,820.00	4,820.00	

Vendor	Vendor Name	Invoice Number	Description	Invoice Date	Net Invoice Amount	Amount Paid	Date Paid
<b>10-52-344</b>							
3850	EASTERN ARIZONA COURIER	1708000630	PRINTING & ADVERTISING	08/31/2017	18.59	18.59	09/13/2017
3850	EASTERN ARIZONA COURIER	1708000998	PRINTING & ADVERTISING	08/31/2017	293.55	293.55	09/13/2017
5080	MCMURRAY COMMUNICATIONS	LOCAL SPORT	PRINTING & ADVERTISING	08/31/2017	39.80	39.80	09/13/2017
Total 10-52-344:					351.94	351.94	
<b>10-52-347</b>							
2905	CASELLE, INC.	82645	SOFTWARE SUPPORT	09/01/2017	682.50	682.50	09/06/2017
Total 10-52-347:					682.50	682.50	
<b>10-52-350</b>							
51	TERRY HINTON	AUGUST2017	PICKUP ALLOWANCE	09/21/2017	800.00	800.00	09/21/2017
Total 10-52-350:					800.00	800.00	
<b>10-52-402</b>							
1600	ARIZ DEPT OF REVENUE-TPT	AUG2017	USE TAX	09/12/2017	514.20	514.20	09/13/2017
Total 10-52-402:					514.20	514.20	
<b>10-52-505</b>							
2320	CHASE CARD SERVICES	081917	MARRIOTT	08/19/2017	207.34	207.34	09/13/2017
Total 10-52-505:					207.34	207.34	
<b>10-52-535</b>							
5667	MATT N. CLIFFORD, P.C.	SEPT2017	POSTAGE	09/05/2017	23.50	23.50	09/06/2017
6250	PETTY CASH	082917	POSTAGE	08/29/2017	23.75	23.75	09/21/2017
6250	PETTY CASH	083017	P-CARD	08/30/2017	11.70	11.70	09/21/2017
6250	PETTY CASH	091417	POSTAGE	09/14/2017	26.50	26.50	09/21/2017
6355	PITNEY BOWES	3101528338	LEASE/POSTAGE	08/31/2017	305.44	305.44	09/06/2017
Total 10-52-535:					343.89	343.89	
<b>10-52-540</b>							
2320	CHASE CARD SERVICES	081217	WALMART	08/12/2017	349.10	349.10	09/13/2017
6250	PETTY CASH	08102017	LAMINATING	08/10/2017	3.75	3.75	09/21/2017
6520	QUILL CORPORATION	008745018	OFFICE SUPPLIES	08/02/2017	43.66	43.66	09/28/2017
6520	QUILL CORPORATION	1022600	OFFICE SUPPLIES	09/20/2017	86.04	86.04	09/28/2017
6520	QUILL CORPORATION	9493061	OFFICE SUPPLIES	08/30/2017	51.15	51.15	09/13/2017
6520	QUILL CORPORATION	9498465	OFFICE SUPPLIES	08/31/2017	49.87	49.87	09/13/2017
6520	QUILL CORPORATION	9981679	OFFICE SUPPLIES	09/19/2017	96.30	96.30	09/28/2017
6520	QUILL CORPORATION	9984123	OFFICE SUPPLIES	09/19/2017	.78	.78	09/28/2017
6520	QUILL CORPORATION	9990490	OFFICE SUPPLIES	09/20/2017	31.32	31.32	09/28/2017
8245	WALMART COMMUNITY/GEMB	007888	CREAMER	08/03/2017	4.08	4.08	09/06/2017
Total 10-52-540:					716.05	716.05	
<b>10-52-542</b>							
4645	HOME DEPOT CREDIT SERVIC	1012869	COURTHOUSE	07/31/2017	195.13	195.13	09/06/2017
4645	HOME DEPOT CREDIT SERVIC	2031270	KWIKSETKEY	07/20/2017	4.30	4.30	09/06/2017
4645	HOME DEPOT CREDIT SERVIC	3031203	COURTHOUSE	07/19/2017	82.95	82.95	09/06/2017
4645	HOME DEPOT CREDIT SERVIC	4581559	FLAT BASE PAINT	08/07/2017	9.79	9.79	09/06/2017
Total 10-52-542:					292.17	292.17	

Vendor	Vendor Name	Invoice Number	Description	Invoice Date	Net Invoice Amount	Amount Paid	Date Paid
<b>10-52-543</b>							
8245	WALMART COMMUNITY/GEMB	006677	SUPPLIES	08/03/2017	90.62	90.62	09/06/2017
8245	WALMART COMMUNITY/GEMB	009251	SUPPLIES	08/01/2017	43.51-	43.51-	09/06/2017
Total 10-52-543:					47.11	47.11	
<b>10-52-590</b>							
8235	WATER DEPOT	2402	REFILL	08/22/2017	30.75	30.75	09/06/2017
8235	WATER DEPOT	3433	REFILL	08/14/2017	20.00	20.00	09/06/2017
Total 10-52-590:					50.75	50.75	
<b>10-52-748</b>							
2320	CHASE CARD SERVICES	081717	BARRACUDA	08/17/2017	899.00	899.00	09/13/2017
3435	DAN MARTIN	6023	IT CONSULTING	09/05/2017	360.00	360.00	09/13/2017
Total 10-52-748:					1,259.00	1,259.00	
<b>10-55-310</b>							
8050	CENTURY LINK	928428511085	TELEPHONE	08/22/2017	.02	.02	09/13/2017
4364	IMPACT TELECOM	608591142	LONG DISTANCE	09/10/2017	.67	.67	09/21/2017
8130	VALLEY TELECOM	33664-002/092	TELEPHONE	09/20/2017	22.82	22.82	09/28/2017
Total 10-55-310:					23.51	23.51	
<b>10-55-327</b>							
3460	DAVID B. GRIFFITH	CR2013-263	ATTORNEY	05/09/2017	600.00	600.00	09/28/2017
3460	DAVID B. GRIFFITH	CR2017-072	ATTORNEY	07/12/2017	600.00	600.00	09/28/2017
3460	DAVID B. GRIFFITH	CR2017-80	ATTORNEY	08/16/2017	600.00	600.00	09/28/2017
Total 10-55-327:					1,800.00	1,800.00	
<b>10-55-540</b>							
6250	PETTY CASH	082317	LAMINATING	08/23/2017	2.50	2.50	09/21/2017
6250	PETTY CASH	082817	LAMINATING	08/28/2017	1.25	1.25	09/21/2017
6520	QUILL CORPORATION	008745018	OFFICE SUPPLIES	08/02/2017	6.37	6.37	09/28/2017
6520	QUILL CORPORATION	1022600	OFFICE SUPPLIES	09/20/2017	12.55	12.55	09/28/2017
6520	QUILL CORPORATION	9493061	OFFICE SUPPLIES	08/30/2017	7.46	7.46	09/13/2017
6520	QUILL CORPORATION	9498465	OFFICE SUPPLIES	08/31/2017	7.27	7.27	09/13/2017
6520	QUILL CORPORATION	9981679	OFFICE SUPPLIES	09/19/2017	14.04	14.04	09/28/2017
6520	QUILL CORPORATION	9984123	OFFICE SUPPLIES	09/19/2017	.11	.11	09/28/2017
6520	QUILL CORPORATION	9990490	OFFICE SUPPLIES	09/20/2017	4.57	4.57	09/28/2017
Total 10-55-540:					56.12	56.12	
<b>10-55-548</b>							
1990	ARIZONA SUPREME COURT	2018-0000012	COMPUTERS/PRINTER	08/31/2017	1,500.00	1,500.00	09/13/2017
Total 10-55-548:					1,500.00	1,500.00	
<b>10-62-102</b>							
669	SEAN HINTON	090917	WEIGHT ROOM	09/09/2017	144.00	144.00	09/13/2017
669	SEAN HINTON	092317	WEIGHT ROOM	09/27/2017	144.00	144.00	09/28/2017
Total 10-62-102:					288.00	288.00	
<b>10-62-150</b>							
1930	ARIZONA STATE PRISON - SAF	S01111170830	LABOR	09/05/2017	93.75	93.75	09/13/2017

Vendor	Vendor Name	Invoice Number	Description	Invoice Date	Net Invoice Amount	Amount Paid	Date Paid
1930	ARIZONA STATE PRISON - SAF	S01111170914	LABOR	09/18/2017	97.50	97.50	09/21/2017
1930	ARIZONA STATE PRISON - SAF	TOT18-04	LABOR	09/05/2017	7.31	7.31	09/13/2017
1930	ARIZONA STATE PRISON - SAF	TOT18-05	LABOR	09/18/2017	6.40	6.40	09/21/2017
Total 10-62-150:					204.96	204.96	
<b>10-62-311</b>							
7827	TRANSWORLD NETWORK COR	14157808-A9	INTERNET	09/16/2017	4.11	4.11	09/28/2017
7827	TRANSWORLD NETWORK COR	14162692-A10	INTERNET	09/22/2017	2.23	2.23	09/28/2017
8195	VERIZON WIRELESS	9791726905	AIR CARDS/CELL	08/26/2017	70.54	70.54	09/06/2017
Total 10-62-311:					76.88	76.88	
<b>10-62-312</b>							
4302	CITY OF SAFFORD	13-425.01/0831	DALEY ESTATES PARK	08/31/2017	281.61	281.61	09/13/2017
4302	CITY OF SAFFORD	15-268.01/0831	CEMETARY/SPASH PARK	08/31/2017	360.25	360.25	09/13/2017
4302	CITY OF SAFFORD	16-385.01/0831	REAY LANE PARK	08/31/2017	31.89	31.89	09/13/2017
4302	CITY OF SAFFORD	17-830.01/0831	LANDSCAPE METER	08/31/2017	67.06	67.06	09/13/2017
Total 10-62-312:					740.81	740.81	
<b>10-62-321</b>							
633	ART TRUJILLO	0829-0907	BASKETBALL REF	08/29/2017	400.00	400.00	09/13/2017
633	ART TRUJILLO	0912-0921	BASKETBALL REF	09/21/2017	400.00	400.00	09/28/2017
10055	KAYLA PETERSON	08/29-09/07	ADULT BASKETBALL	08/29/2017	400.00	400.00	09/13/2017
10055	KAYLA PETERSON	0912-0921	ADULT BASKETBALL	09/21/2017	250.00	250.00	09/28/2017
10060	KENOSHE WRIGHT	0912-0921	BASKETBALL REF	09/21/2017	200.00	200.00	09/28/2017
Total 10-62-321:					1,650.00	1,650.00	
<b>10-62-341</b>							
1036	A & G TURF EQUIPMENT, INC.	D446862	CABLE ASSY	08/22/2017	54.93	54.93	09/06/2017
6025	BLUE TARP FINANCIAL	38562663	HONDA OHV ENGINE	08/25/2017	314.99	314.99	09/21/2017
3075	FIRST CALL AUTO PARTS	2752-137927	ENAMEL PAINT	09/19/2017	13.07	13.07	09/28/2017
3075	FIRST CALL AUTO PARTS	2752-137928	ENAMEL PAINT	09/19/2017	78.42	78.42	09/28/2017
3075	FIRST CALL AUTO PARTS	2752-138257	INSP TOOL	09/21/2017	13.06	13.06	09/28/2017
9014	GILA VALLEY POLARIS	6180	RPLC KIT	08/14/2017	149.99	149.99	09/06/2017
4795	INDUSTRIAL ELECTRICAL SER	6508	SEALS	08/03/2017	18.82	18.82	09/06/2017
4795	INDUSTRIAL ELECTRICAL SER	6576	KOYO BEARING	09/06/2017	9.27	9.27	09/13/2017
5530	MACK'S AUTO SUPPLY	819838	CHAMBER	08/24/2017	117.59	117.59	09/06/2017
5530	MACK'S AUTO SUPPLY	822146	HOSE	09/14/2017	264.72	264.72	09/28/2017
5530	MACK'S AUTO SUPPLY	822877	GLOVES	09/21/2017	127.84	127.84	09/28/2017
1818	STOTZ EQUIPMENT	P28571	HARDWARE KIT	08/16/2017	81.83	81.83	09/06/2017
1818	STOTZ EQUIPMENT	P28624	HARDWARE KIT	08/21/2017	55.49	55.49	09/06/2017
1818	STOTZ EQUIPMENT	P28972	BLADES	09/18/2017	101.56	101.56	09/28/2017
Total 10-62-341:					1,401.58	1,401.58	
<b>10-62-350</b>							
5530	MACK'S AUTO SUPPLY	820667	OIL FILTER	08/31/2017	38.53	38.53	09/13/2017
Total 10-62-350:					38.53	38.53	
<b>10-62-533</b>							
6250	PETTY CASH	072717	OUT OF POCKET/GARY	07/27/2017	10.90	10.90	09/21/2017
8245	WALMART COMMUNITY/GEMB	002680	BATTERIES	08/23/2017	74.60	74.60	09/28/2017



Vendor	Vendor Name	Invoice Number	Description	Invoice Date	Net Invoice Amount	Amount Paid	Date Paid
Total 10-62-533:					85.50	85.50	
<b>10-62-538</b>							
4125	FERTIZONA - THATCHER, LLC	19019209	TOP CHOICE 50#	09/20/2017	2,387.84	2,387.84	09/21/2017
Total 10-62-538:					2,387.84	2,387.84	
<b>10-62-541</b>							
2210	CLASS C SOLUTIONS GROUP	1484015001	NUTS & BOLTS	08/31/2017	34.16	34.16	09/13/2017
2210	CLASS C SOLUTIONS GROUP	1484015004	NUTS & BOLTS	09/01/2017	2.13	2.13	09/13/2017
4645	HOME DEPOT CREDIT SERVIC	3580831	SPRINKER PARTS	07/19/2017	244.31	244.31	09/06/2017
6880	SAFFORD BUILDERS SUPPLY C	734324	PRIMER	08/02/2017	70.94	70.94	09/06/2017
1818	STOTZ EQUIPMENT	P28928	HEDGE TRIMMER	09/13/2017	436.35	436.35	09/21/2017
Total 10-62-541:					787.89	787.89	
<b>10-62-542</b>							
4645	HOME DEPOT CREDIT SERVIC	3074651	FORGED RAKE	07/19/2017	28.33	28.33	09/06/2017
4645	HOME DEPOT CREDIT SERVIC	5043008	PVC ADAPTER	07/27/2017	14.52	14.52	09/06/2017
4645	HOME DEPOT CREDIT SERVIC	8581019	HOSEBIB	07/24/2017	10.32	10.32	09/06/2017
5415	LESLIE'S POOL SUPPLIES INC	3000-424119	SPLASH PAD SUPPLIES	06/06/2017	287.87	287.87	09/13/2017
5415	LESLIE'S POOL SUPPLIES INC	3000-425745	CHLORINE	06/13/2017	212.85	212.85	09/13/2017
5415	LESLIE'S POOL SUPPLIES INC	3000-444087	CHLORINE	08/28/2017	212.85	212.85	09/13/2017
Total 10-62-542:					766.74	766.74	
<b>10-62-543</b>							
8245	WALMART COMMUNITY/GEMB	006677	SUPPLIES	08/03/2017	87.60	87.60	09/06/2017
8245	WALMART COMMUNITY/GEMB	009251	SUPPLIES	08/01/2017	.00	.00	
Total 10-62-543:					87.60	87.60	
<b>10-62-553</b>							
3075	FIRST CALL AUTO PARTS	2752-130688	BATTERY	08/07/2017	96.58	96.58	09/06/2017
3075	FIRST CALL AUTO PARTS	2752-130715	CORE RETURN	08/07/2017	10.91-	10.91-	09/06/2017
Total 10-62-553:					85.67	85.67	
<b>10-62-555</b>							
3075	FIRST CALL AUTO PARTS	EB28511411	VEHICLE MAINTENANCE SUPP	07/25/2017	.00	.00	
3075	FIRST CALL AUTO PARTS	EB30394411	VEHICLE MAINTENANCE SUPP	08/23/2017	.00	.00	
7945	SENERGY PETROLEUM	383212	GAS/DIESEL	09/14/2017	386.89	386.89	09/21/2017
1818	STOTZ EQUIPMENT	P28750	FUEL	08/29/2017	83.97	83.97	09/06/2017
Total 10-62-555:					470.86	470.86	
<b>10-62-590</b>							
4645	HOME DEPOT CREDIT SERVIC	1080028	REPLELLANT	08/10/2017	32.57	32.57	09/06/2017
Total 10-62-590:					32.57	32.57	
<b>10-70-310</b>							
8050	CENTURY LINK	928428511085	TELEPHONE	08/22/2017	.16	.16	09/13/2017
4364	IMPACT TELECOM	608591142	LONG DISTANCE	09/10/2017	5.86	5.86	09/21/2017
8130	VALLEY TELECOM	33664-002/092	TELEPHONE	09/20/2017	200.60	200.60	09/28/2017

Vendor	Vendor Name	Invoice Number	Description	Invoice Date	Net Invoice Amount	Amount Paid	Date Paid
Total 10-70-310:					206.62	206.62	
<b>10-70-311</b>							
7827	TRANSWORLD NETWORK COR	14157808-A9	INTERNET	09/16/2017	32.73	32.73	09/28/2017
7827	TRANSWORLD NETWORK COR	14162692-A10	INTERNET	09/22/2017	17.70	17.70	09/28/2017
8195	VERIZON WIRELESS	9791726905	AIR CARDS/CELL	08/26/2017	561.11	561.11	09/06/2017
Total 10-70-311:					611.54	611.54	
<b>10-70-340</b>							
6250	PETTY CASH	090717	ACE	09/07/2017	27.24	27.24	09/21/2017
Total 10-70-340:					27.24	27.24	
<b>10-70-341</b>							
2320	CHASE CARD SERVICES	080117	CHIEF SUPPLY	08/01/2017	108.95	108.95	09/13/2017
2320	CHASE CARD SERVICES	080317	CHIEF SUPPLY	08/03/2017	293.21	293.21	09/13/2017
2320	CHASE CARD SERVICES	082217	CHIEF SUPPLY	08/22/2017	11.14	11.14	09/13/2017
3075	FIRST CALL AUTO PARTS	2752-135586	FAN CLUTCH	09/05/2017	364.82	364.82	09/13/2017
Total 10-70-341:					778.12	778.12	
<b>10-70-344</b>							
3850	EASTERN ARIZONA COURIER	1708000630	PRINTING & ADVERTISING	08/31/2017	30.68	30.68	09/13/2017
3850	EASTERN ARIZONA COURIER	1708000998	PRINTING & ADVERTISING	08/31/2017	484.36	484.36	09/13/2017
5080	MCMURRAY COMMUNICATIONS	LOCAL SPORT	PRINTING & ADVERTISING	08/31/2017	65.67	65.67	09/13/2017
Total 10-70-344:					580.71	580.71	
<b>10-70-350</b>							
3075	FIRST CALL AUTO PARTS	2752-134436	ENGINE MOUNT	08/29/2017	144.98	144.98	09/13/2017
3075	FIRST CALL AUTO PARTS	2752-134771	TRANSFLD	08/31/2017	17.64	17.64	09/13/2017
6999	SANDERSON FORD	315898	PUMP ASY	09/12/2017	691.84	691.84	09/21/2017
6999	SANDERSON FORD	FOW307902	AIR HOSE	08/15/2017	125.96	125.96	09/06/2017
8360	WINZER	5906729	fuses	07/16/2017	310.20	310.20	09/06/2017
Total 10-70-350:					1,290.62	1,290.62	
<b>10-70-360</b>							
4420	GRAHAM CO BOARD OF SUPE	2018-0000001	ANIMAL CONTROL	08/29/2017	153.00	153.00	09/06/2017
Total 10-70-360:					153.00	153.00	
<b>10-70-505</b>							
6250	PETTY CASH	071917	STONE GARDEN TRUCK	07/19/2017	44.00	44.00	09/21/2017
Total 10-70-505:					44.00	44.00	
<b>10-70-535</b>							
6250	PETTY CASH	081417	POSTAGE	08/14/2017	7.20	7.20	09/21/2017
6250	PETTY CASH	082417	POSTAGE	08/24/2017	41.05	41.05	09/21/2017
Total 10-70-535:					48.25	48.25	
<b>10-70-540</b>							
6250	PETTY CASH	080717	FRAMES	08/07/2017	18.42	18.42	09/21/2017
6520	QUILL CORPORATION	008745018	OFFICE SUPPLIES	08/02/2017	24.56	24.56	09/28/2017

Vendor	Vendor Name	Invoice Number	Description	Invoice Date	Net Invoice Amount	Amount Paid	Date Paid
6520	QUILL CORPORATION	1022600	OFFICE SUPPLIES	09/20/2017	48.39	48.39	09/28/2017
6520	QUILL CORPORATION	9493061	OFFICE SUPPLIES	08/30/2017	28.77	28.77	09/13/2017
6520	QUILL CORPORATION	9498465	OFFICE SUPPLIES	08/31/2017	28.05	28.05	09/13/2017
6520	QUILL CORPORATION	9981679	OFFICE SUPPLIES	09/19/2017	54.17	54.17	09/28/2017
6520	QUILL CORPORATION	9984123	OFFICE SUPPLIES	09/19/2017	.44	.44	09/28/2017
6520	QUILL CORPORATION	9990490	OFFICE SUPPLIES	09/20/2017	17.61	17.61	09/28/2017
8235	WATER DEPOT	3461	REFILL	09/18/2017	30.00	30.00	09/28/2017
8235	WATER DEPOT	3462	REFILL	09/18/2017	24.00	24.00	09/28/2017
Total 10-70-540:					274.41	274.41	
<b>10-70-541</b>							
2320	CHASE CARD SERVICES	082417	RSR GROUP	08/24/2017	412.05	412.05	09/13/2017
Total 10-70-541:					412.05	412.05	
<b>10-70-543</b>							
8245	WALMART COMMUNITY/GEMB	006677	SUPPLIES	08/03/2017	75.52	75.52	09/06/2017
8245	WALMART COMMUNITY/GEMB	009251	SUPPLIES	08/01/2017	.00	.00	
Total 10-70-543:					75.52	75.52	
<b>10-70-544</b>							
6990	SAN DIEGO POLICE EQUIPMEN	629163	AMMO	09/05/2017	1,954.70	1,954.70	09/13/2017
6990	SAN DIEGO POLICE EQUIPMEN	629343	AMMO	09/14/2017	3,169.80	3,169.80	09/28/2017
Total 10-70-544:					5,124.50	5,124.50	
<b>10-70-549</b>							
2320	CHASE CARD SERVICES	080817	DIRECTPROMOTIONALS	08/08/2017	503.97	503.97	09/13/2017
2320	CHASE CARD SERVICES	080917	CUSTOM WRISTBAND	08/09/2017	424.89	424.89	09/13/2017
Total 10-70-549:					928.86	928.86	
<b>10-70-553</b>							
3765	EAST PENN MANUFACTURING	5876692	CORE	08/25/2017	280.38	280.38	09/13/2017
3075	FIRST CALL AUTO PARTS	2752-129323	CORE RETURN	07/31/2017	327.30	327.30	09/06/2017
3075	FIRST CALL AUTO PARTS	2752-132220	BATTERY	08/16/2017	267.95	267.95	09/06/2017
5530	MACK'S AUTO SUPPLY	808196/2	CORE	05/22/2017	58.04	58.04	09/13/2017
5530	MACK'S AUTO SUPPLY	821439	CORE	09/08/2017	125.30	125.30	09/13/2017
Total 10-70-553:					404.37	404.37	
<b>10-70-555</b>							
1396	AMSOIL INC	17368868 RI	LUBRICANTS	08/03/2017	1,372.73	1,372.73	09/06/2017
7945	SENERGY PETROLEUM	383212	GAS/DIESEL	09/14/2017	1,433.62	1,433.62	09/21/2017
7314	SOUTHWESTERN BG, INC	47810	DEGREASER	09/06/2017	313.75	313.75	09/13/2017
7314	SOUTHWESTERN BG, INC	47811	IV TOOL	09/06/2017	84.98	84.98	09/13/2017
7314	SOUTHWESTERN BG, INC	47859	FUELS	09/19/2017	103.66	103.66	09/28/2017
Total 10-70-555:					3,308.74	3,308.74	
<b>10-70-748</b>							
3435	DAN MARTIN	6023	IT CONSULTING	09/05/2017	360.00	360.00	09/13/2017
Total 10-70-748:					360.00	360.00	

Vendor	Vendor Name	Invoice Number	Description	Invoice Date	Net Invoice Amount	Amount Paid	Date Paid
<b>10-72-310</b>							
8050	CENTURY LINK	928428511085	TELEPHONE	08/22/2017	.07	.07	09/13/2017
4364	IMPACT TELECOM	608591142	LONG DISTANCE	09/10/2017	2.60	2.60	09/21/2017
8130	VALLEY TELECOM	33664-002/092	TELEPHONE	09/20/2017	88.89	88.89	09/28/2017
Total 10-72-310:					91.56	91.56	
<b>10-72-341</b>							
4225	GALLS	008238096	LED LIGHT	09/07/2017	239.58	239.58	09/21/2017
Total 10-72-341:					239.58	239.58	
<b>10-72-342</b>							
2830	C E S SAFFORD	SAF/035288	VOLT SWITCH	08/16/2017	109.10	109.10	09/13/2017
8407	WOODSIDE CONSTRUCTION, L	226	FIRE DEPARTMENT ROOF	09/20/2017	18,295.00	18,295.00	09/28/2017
Total 10-72-342:					18,404.10	18,404.10	
<b>10-72-350</b>							
8360	WINZER	5906729	fuses	07/16/2017	310.20	310.20	09/06/2017
Total 10-72-350:					310.20	310.20	
<b>10-72-505</b>							
1185	ALERT - ALL CORP	217090144	BACKPACK SCHOOL KITS	09/07/2017	2,070.00	2,070.00	09/21/2017
2320	CHASE CARD SERVICES	080217	STATE FIRE TRAINING	08/02/2017	140.23	140.23	09/13/2017
Total 10-72-505:					2,210.23	2,210.23	
<b>10-72-530</b>							
6810	R & R PIZZA	082917	PIZZA-TRAINING	08/29/2017	230.43	230.43	09/06/2017
6190	SE BOTTLING CO OF AZ, INC	209226	SODAS	08/02/2017	134.79	134.79	09/13/2017
Total 10-72-530:					365.22	365.22	
<b>10-72-533</b>							
6880	SAFFORD BUILDERS SUPPLY C	736620	SUPPLIES	08/18/2017	68.99	68.99	09/06/2017
6880	SAFFORD BUILDERS SUPPLY C	736703	GRAPHITE	08/19/2017	85.34	85.34	09/06/2017
6880	SAFFORD BUILDERS SUPPLY C	K37631	VOCOILENM	08/25/2017	89.33	89.33	09/06/2017
Total 10-72-533:					243.66	243.66	
<b>10-72-540</b>							
6520	QUILL CORPORATION	008745018	OFFICE SUPPLIES	08/02/2017	.90	.90	09/28/2017
6520	QUILL CORPORATION	1022600	OFFICE SUPPLIES	09/20/2017	1.78	1.78	09/28/2017
6520	QUILL CORPORATION	9493061	OFFICE SUPPLIES	08/30/2017	1.06	1.06	09/13/2017
6520	QUILL CORPORATION	9498465	OFFICE SUPPLIES	08/31/2017	1.04	1.04	09/13/2017
6520	QUILL CORPORATION	9981679	OFFICE SUPPLIES	09/19/2017	2.02	2.02	09/28/2017
6520	QUILL CORPORATION	9984123	OFFICE SUPPLIES	09/19/2017	.02	.02	09/28/2017
6520	QUILL CORPORATION	9990490	OFFICE SUPPLIES	09/20/2017	.64	.64	09/28/2017
Total 10-72-540:					7.46	7.46	
<b>10-72-543</b>							
8245	WALMART COMMUNITY/GEMB	006677	SUPPLIES	08/03/2017	24.17	24.17	09/06/2017
8245	WALMART COMMUNITY/GEMB	009251	SUPPLIES	08/01/2017	.00	.00	

Vendor	Vendor Name	Invoice Number	Description	Invoice Date	Net Invoice Amount	Amount Paid	Date Paid
Total 10-72-543:					24.17	24.17	
<b>10-72-555</b>							
7945	SENERGY PETROLEUM	383212	GAS/DIESEL	09/14/2017	192.67	192.67	09/21/2017
Total 10-72-555:					192.67	192.67	
<b>10-72-590</b>							
1463	ANTHEM SPORTS, LLC	194229	FIRE STATION FLAG POLE	09/21/2017	889.95	889.95	09/28/2017
Total 10-72-590:					889.95	889.95	
<b>10-72-741</b>							
7662	THE BODY DOC'S	1354	FIRETRUCK PAINT	08/14/2017	2,032.75	2,032.75	09/06/2017
7960	UNITED FIRE EQUIP. CO.	670523	TURNOUTS	09/01/2017	2,130.43	2,130.43	09/13/2017
Total 10-72-741:					4,163.18	4,163.18	
<b>10-81-140</b>							
7919	UNIFIRST CORPORATION	3100850800	UNIFORMS	08/02/2017	169.25	169.25	09/06/2017
7919	UNIFIRST CORPORATION	3100851953	UNIFORMS	08/09/2017	169.25	169.25	09/06/2017
7919	UNIFIRST CORPORATION	3100853114	UNIFORMS	08/16/2017	172.13	172.13	09/06/2017
7919	UNIFIRST CORPORATION	3100854281	UNIFORMS	08/23/2017	172.39	172.39	09/06/2017
7919	UNIFIRST CORPORATION	3100855455	UNIFORMS	08/30/2017	169.51	169.51	09/13/2017
7919	UNIFIRST CORPORATION	3100856621	UNIFORMS	09/06/2017	172.39	172.39	09/13/2017
7919	UNIFIRST CORPORATION	3100857789	UNIFORMS	09/13/2017	203.02	203.02	09/28/2017
7919	UNIFIRST CORPORATION	3100858973	UNIFORMS	09/20/2017	169.25	169.25	09/28/2017
Total 10-81-140:					1,397.19	1,397.19	
<b>10-81-150</b>							
1930	ARIZONA STATE PRISON - SAF	S01111170830	LABOR	09/05/2017	112.50	112.50	09/13/2017
1930	ARIZONA STATE PRISON - SAF	S01111170914	LABOR	09/18/2017	86.25	86.25	09/21/2017
1930	ARIZONA STATE PRISON - SAF	TOT18-04	LABOR	09/05/2017	7.31	7.31	09/13/2017
1930	ARIZONA STATE PRISON - SAF	TOT18-05	LABOR	09/18/2017	6.40	6.40	09/21/2017
Total 10-81-150:					212.46	212.46	
<b>10-81-310</b>							
8050	CENTURY LINK	928428511085	TELEPHONE	08/22/2017	.03	.03	09/13/2017
4364	IMPACT TELECOM	608591142	LONG DISTANCE	09/10/2017	1.30	1.30	09/21/2017
8130	VALLEY TELECOM	33664-002/092	TELEPHONE	09/20/2017	44.45	44.45	09/28/2017
Total 10-81-310:					45.78	45.78	
<b>10-81-311</b>							
7827	TRANSWORLD NETWORK COR	14157808-A9	INTERNET	09/16/2017	4.77	4.77	09/28/2017
7827	TRANSWORLD NETWORK COR	14162692-A10	INTERNET	09/22/2017	2.58	2.58	09/28/2017
8195	VERIZON WIRELESS	9791726905	AIR CARDS/CELL	08/26/2017	81.76	81.76	09/06/2017
Total 10-81-311:					89.11	89.11	
<b>10-81-312</b>							
4302	CITY OF SAFFORD	15-273.01/0831	SHOP	08/31/2017	150.71	150.71	09/13/2017
Total 10-81-312:					150.71	150.71	

Vendor	Vendor Name	Invoice Number	Description	Invoice Date	Net Invoice Amount	Amount Paid	Date Paid
<b>10-81-341</b>							
6775	ROCKY MOUNTAIN DISTRIBUTI	557655	ATC	08/09/2017	77.54	77.54	09/06/2017
Total 10-81-341:					77.54	77.54	
<b>10-81-342</b>							
1998	RATTLE SNAKE EXTERMINATIN	48125	EXTERMINATING SERVICES	08/02/2017	140.00	140.00	09/06/2017
1998	RATTLE SNAKE EXTERMINATIN	48574	EXTERMINATING SERVICES	09/06/2017	140.00	140.00	09/13/2017
Total 10-81-342:					280.00	280.00	
<b>10-81-350</b>							
2105	AUDIO VISIONS / RADIO SHACK	10043173/22-	CD RECEIVER	08/03/2017	122.14	122.14	09/06/2017
5530	MACK'S AUTO SUPPLY	811815	WHEEL BEARING	06/20/2017	490.07	490.07	09/13/2017
5530	MACK'S AUTO SUPPLY	811819	PROP SHAFT	06/20/2017	427.08	427.08	09/13/2017
5530	MACK'S AUTO SUPPLY	812096	EXHAUST ADAPTER	06/21/2017	387.56	387.56	09/13/2017
8360	WINZER	5906729	fuses	07/16/2017	310.21	310.21	09/06/2017
Total 10-81-350:					1,737.06	1,737.06	
<b>10-81-505</b>							
6250	PETTY CASH	08302017	TRAVEL-JARED	08/30/2017	11.00	11.00	09/21/2017
6250	PETTY CASH	08302017	TRAVEL-RUSTY	08/30/2017	11.00	11.00	09/21/2017
Total 10-81-505:					22.00	22.00	
<b>10-81-533</b>							
4645	HOME DEPOT CREDIT SERVIC	5633391	TELESCOPING ALUMINUM	07/17/2017	235.98	235.98	09/06/2017
5530	MACK'S AUTO SUPPLY	822111	CREEPER-PLASTIC BODY	09/14/2017	76.36	76.36	09/28/2017
7232	SNAP ON TOOLS	08011721909	6PC MM SET	08/01/2017	398.22	398.22	09/06/2017
7232	SNAP ON TOOLS	08221722210	LI-ION BATTERY	08/22/2017	279.24	279.24	09/06/2017
7232	SNAP ON TOOLS	09121722518	CORDITE COMPACT	09/12/2017	365.32	365.32	09/21/2017
Total 10-81-533:					1,355.12	1,355.12	
<b>10-81-540</b>							
6520	QUILL CORPORATION	008745018	OFFICE SUPPLIES	08/02/2017	2.73	2.73	09/28/2017
6520	QUILL CORPORATION	1022600	OFFICE SUPPLIES	09/20/2017	5.38	5.38	09/28/2017
6520	QUILL CORPORATION	9493061	OFFICE SUPPLIES	08/30/2017	3.20	3.20	09/13/2017
6520	QUILL CORPORATION	9498465	OFFICE SUPPLIES	08/31/2017	3.12	3.12	09/13/2017
6520	QUILL CORPORATION	9981679	OFFICE SUPPLIES	09/19/2017	6.02	6.02	09/28/2017
6520	QUILL CORPORATION	9984123	OFFICE SUPPLIES	09/19/2017	.05	.05	09/28/2017
6520	QUILL CORPORATION	9990490	OFFICE SUPPLIES	09/20/2017	1.96	1.96	09/28/2017
Total 10-81-540:					22.46	22.46	
<b>10-81-541</b>							
2830	C E S SAFFORD	SAF/035304	PORTABLE CORD	08/17/2017	41.76	41.76	09/13/2017
2210	CLASS C SOLUTIONS GROUP	1484015001	NUTS & BOLTS	08/31/2017	106.74	106.74	09/13/2017
2210	CLASS C SOLUTIONS GROUP	1484015004	NUTS & BOLTS	09/01/2017	6.67	6.67	09/13/2017
5530	MACK'S AUTO SUPPLY	819515	CONTACT TIP	08/22/2017	188.42	188.42	09/06/2017
5530	MACK'S AUTO SUPPLY	819847	SPRAY INSULATION	08/24/2017	196.66	196.66	09/06/2017
5530	MACK'S AUTO SUPPLY	819878	LED WORKLAMP	08/24/2017	142.43	142.43	09/06/2017
5530	MACK'S AUTO SUPPLY	819915	NOZZLE	08/24/2017	69.91	69.91	09/06/2017
5530	MACK'S AUTO SUPPLY	820230	HOSE	08/28/2017	99.53	99.53	09/06/2017
6180	PECK'S WELDING	647837	PURLINS	08/02/2017	400.81	400.81	09/06/2017
6180	PECK'S WELDING	647845	PANELS	08/10/2017	2,677.79	2,677.79	09/06/2017

Vendor	Vendor Name	Invoice Number	Description	Invoice Date	Net Invoice Amount	Amount Paid	Date Paid
Total 10-81-541:					3,930.72	3,930.72	
<b>10-81-542</b>							
1252	AIRGAS USA, LLC	9066956171	VORTECH	08/24/2017	148.73	148.73	09/06/2017
1252	AIRGAS USA, LLC	9067509972	ELECT PLSM	09/11/2017	670.31	670.31	09/21/2017
4645	HOME DEPOT CREDIT SERVIC	3032290	SUPPLIES	08/08/2017	304.33	304.33	09/06/2017
6180	PECK'S WELDING	347864	PURLINS	08/30/2017	1,753.57	1,753.57	09/13/2017
6880	SAFFORD BUILDERS SUPPLY C	736045	KEY STEM	08/15/2017	17.57	17.57	09/06/2017
6880	SAFFORD BUILDERS SUPPLY C	736496	VLV GATE	08/17/2017	26.19	26.19	09/06/2017
Total 10-81-542:					2,920.70	2,920.70	
<b>10-81-543</b>							
8245	WALMART COMMUNITY/GEMB	006677	SUPPLIES	08/03/2017	24.17	24.17	09/06/2017
8245	WALMART COMMUNITY/GEMB	009251	SUPPLIES	08/01/2017	.00	.00	
Total 10-81-543:					24.17	24.17	
<b>10-81-550</b>							
3800	EASTERN ARIZONA AG CENTE	CS90285	BOLT	08/15/2017	18.20	18.20	09/06/2017
3800	EASTERN ARIZONA AG CENTE	CS90535	MODULE	08/23/2017	266.86	266.86	09/06/2017
3800	EASTERN ARIZONA AG CENTE	CS90541	COMBO-R	08/23/2017	397.96	397.96	09/06/2017
Total 10-81-550:					683.02	683.02	
<b>10-81-555</b>							
1396	AMSOIL INC	17407895	ALL IN ONE	08/28/2017	689.80	689.80	09/21/2017
1396	AMSOIL INC	17424217 RI	ORMD DIESEL	09/08/2017	161.88	161.88	09/21/2017
3075	FIRST CALL AUTO PARTS	2752-134292	EVAPOR RUST	08/28/2017	25.08	25.08	09/06/2017
7945	SENERGY PETROLEUM	383212	GAS/DIESEL	09/14/2017	217.78	217.78	09/21/2017
Total 10-81-555:					1,094.54	1,094.54	
<b>10-84-150</b>							
1930	ARIZONA STATE PRISON - SAF	S01111170830	LABOR	09/05/2017	30.00	30.00	09/13/2017
1930	ARIZONA STATE PRISON - SAF	S01111170914	LABOR	09/18/2017	22.50	22.50	09/21/2017
1930	ARIZONA STATE PRISON - SAF	TOT18-04	LABOR	09/05/2017	7.31	7.31	09/13/2017
1930	ARIZONA STATE PRISON - SAF	TOT18-05	LABOR	09/18/2017	6.40	6.40	09/21/2017
Total 10-84-150:					66.21	66.21	
<b>10-84-310</b>							
8050	CENTURY LINK	928428511085	TELEPHONE	08/22/2017	.05	.05	09/13/2017
4364	IMPACT TELECOM	608591142	LONG DISTANCE	09/10/2017	1.97	1.97	09/21/2017
8130	VALLEY TELECOM	33664-002/092	TELEPHONE	09/20/2017	67.27	67.27	09/28/2017
Total 10-84-310:					69.29	69.29	
<b>10-84-311</b>							
7827	TRANSWORLD NETWORK COR	14157808-A9	INTERNET	09/16/2017	6.83	6.83	09/28/2017
7827	TRANSWORLD NETWORK COR	14162692-A10	INTERNET	09/22/2017	3.69	3.69	09/28/2017
8195	VERIZON WIRELESS	9791726905	AIR CARDS/CELL	08/26/2017	117.03	117.03	09/06/2017
Total 10-84-311:					127.55	127.55	
<b>10-84-341</b>							
2255	BTM CUSTOM ENGINE	6010	OVERHAUL KIT	09/05/2017	2,062.80	2,062.80	09/13/2017

Vendor	Vendor Name	Invoice Number	Description	Invoice Date	Net Invoice Amount	Amount Paid	Date Paid
2255	BTM CUSTOM ENGINE	6026	REBUILD/ R&R VALVES	09/13/2017	800.34	800.34	09/28/2017
3800	EASTERN ARIZONA AG CENTE	CS90073	FUNNEL	08/07/2017	261.64	261.64	09/06/2017
3800	EASTERN ARIZONA AG CENTE	CS90286	DIPSTICK	08/15/2017	31.42	31.42	09/06/2017
3800	EASTERN ARIZONA AG CENTE	CS90609	DECAL	08/25/2017	25.06	25.06	09/13/2017
3800	EASTERN ARIZONA AG CENTE	CS91065	FITTING	09/13/2017	154.25	154.25	09/28/2017
3800	EASTERN ARIZONA AG CENTE	CS91095	3/4X6 -8U	09/14/2017	9.21	9.21	09/28/2017
3800	EASTERN ARIZONA AG CENTE	CS91111	CAP #6	09/14/2017	30.11	30.11	09/28/2017
3800	EASTERN ARIZONA AG CENTE	CS91177	O-RING	09/18/2017	71.31	71.31	09/28/2017
3800	EASTERN ARIZONA AG CENTE	CS91207	ORF CAP	09/19/2017	28.34	28.34	09/28/2017
4000	EMPIRE SOUTHWEST	EMPS0418956	120G	08/25/2017	2,860.02	2,860.02	09/28/2017
4000	EMPIRE SOUTHWEST	EMPS0418956	12MG	08/25/2017	201.97	201.97	09/28/2017
4000	EMPIRE SOUTHWEST	EMPS4175917	ELEMENT S	08/08/2017	72.53	72.53	09/06/2017
4000	EMPIRE SOUTHWEST	EMPS4181100	CAT ELC 50/50	08/15/2017	221.88	221.88	09/06/2017
4000	EMPIRE SOUTHWEST	EMPS4186262	RELAY	08/22/2017	197.71	197.71	09/06/2017
4000	EMPIRE SOUTHWEST	EMPS4188415	LEVER G	08/24/2017	852.36	852.36	09/06/2017
4000	EMPIRE SOUTHWEST	EMPS4205444	WASHER	09/18/2017	641.17	641.17	09/28/2017
5530	MACK'S AUTO SUPPLY	817699	AIR FILTER	08/08/2017	71.83	71.83	09/06/2017
5530	MACK'S AUTO SUPPLY	818911	SERPENTINE BELT	08/17/2017	147.29	147.29	09/06/2017
5530	MACK'S AUTO SUPPLY	819527	AIR FILTER	08/22/2017	173.16	173.16	09/06/2017
5530	MACK'S AUTO SUPPLY	820071	INJECTION PUMP	08/25/2017	1,041.34	1,041.34	09/06/2017
6070	OPEN LOOP ENERGY, INC.	117231	CYL CENTER SHIFT	08/30/2017	1,008.46	1,008.46	09/28/2017
5526	RWC INTERNATIONAL, LTD	113686T	CORE DEPOSIT	09/05/2017	880.86	880.86	09/13/2017
1818	STOTZ EQUIPMENT	P28929	GEAR CASE	09/13/2017	377.07	377.07	09/21/2017
Total 10-84-341:					12,222.13	12,222.13	
<b>10-84-350</b>							
3075	FIRST CALL AUTO PARTS	2752-131960	WIPER BLADES	08/15/2017	111.85	111.85	09/06/2017
3075	FIRST CALL AUTO PARTS	2752-133042	OIL FILTER	08/21/2017	9.86	9.86	09/06/2017
3075	FIRST CALL AUTO PARTS	2752-133048	BRAKE ROTOR	08/21/2017	346.62	346.62	09/06/2017
3075	FIRST CALL AUTO PARTS	2752-134243	FUEL FILTER	08/28/2017	26.64	26.64	09/06/2017
3075	FIRST CALL AUTO PARTS	2752-136745	COOLANT	09/11/2017	36.14	36.14	09/21/2017
3075	FIRST CALL AUTO PARTS	2752-136802	GRINDER WHL	09/12/2017	5.43	5.43	09/21/2017
3075	FIRST CALL AUTO PARTS	2752-137001	CABIN FILTER	09/13/2017	34.86	34.86	09/21/2017
3075	FIRST CALL AUTO PARTS	2752-137030	VACUUM GAUGE	09/13/2017	21.81	21.81	09/21/2017
3075	FIRST CALL AUTO PARTS	2752-137062	BRAKE ROTOR	09/13/2017	100.33	100.33	09/21/2017
5530	MACK'S AUTO SUPPLY	822028	FRZ PLUG	09/13/2017	117.42	117.42	09/28/2017
5530	MACK'S AUTO SUPPLY	822090	4FP	09/13/2017	6.76	6.76	09/28/2017
5530	MACK'S AUTO SUPPLY	822112	AXLE SHAFT SEAL	09/14/2017	22.04	22.04	09/28/2017
8360	WINZER	5906729	fuses	07/16/2017	310.20	310.20	09/06/2017
Total 10-84-350:					1,149.96	1,149.96	
<b>10-84-360</b>							
2982	CENTERLINE SUPPLY WEST, IN	00080344	STRIPING PAINT	09/05/2017	1,269.17	1,269.17	09/13/2017
3145	CKC MATERIALS DIVISION	T2778	HOT MIX	08/31/2017	1,342.84	1,342.84	09/13/2017
7820	TRI COUNTY MATERIALS INC	72924	NON SHRINK	08/14/2017	639.60	639.60	09/13/2017
7820	TRI COUNTY MATERIALS INC	73029	NON SHRINK	08/23/2017	639.60	639.60	09/13/2017
Total 10-84-360:					3,891.21	3,891.21	
<b>10-84-533</b>							
4125	FERTIZONA - THATCHER, LLC	19019128	SPRAY HAND GUN	09/11/2017	10.66	10.66	09/13/2017
1818	STOTZ EQUIPMENT	P28983	CHAIN LOOP	09/18/2017	20.17	20.17	09/21/2017
7795	TRACTOR SUPPLY CREDIT PLA	200182291	SAE IMPACT DRIVER	08/24/2017	90.89	90.89	09/13/2017
Total 10-84-533:					121.72	121.72	



Vendor	Vendor Name	Invoice Number	Description	Invoice Date	Net Invoice Amount	Amount Paid	Date Paid
<b>10-84-541</b>							
2210	CLASS C SOLUTIONS GROUP	1484015001	NUTS & BOLTS	08/31/2017	106.74	106.74	09/13/2017
2210	CLASS C SOLUTIONS GROUP	1484015004	NUTS & BOLTS	09/01/2017	6.67	6.67	09/13/2017
4645	HOME DEPOT CREDIT SERVIC	62354	4X4	08/01/2017	27.20	27.20	09/06/2017
1818	STOTZ EQUIPMENT	P27866	PARTS	06/26/2017	16.35	16.35	09/06/2017
Total 10-84-541:					156.96	156.96	
<b>10-84-553</b>							
2545	BIG O TIRES	23492	MOUNT AND BALANCE	07/31/2017	423.98	423.98	09/06/2017
2545	BIG O TIRES	23587	MOUNT AND BALANCE	08/03/2017	1,223.96	1,223.96	09/06/2017
4645	HOME DEPOT CREDIT SERVIC	2581617	BATTERIES	08/09/2017	7.07	7.07	09/06/2017
Total 10-84-553:					1,655.01	1,655.01	
<b>10-84-555</b>							
7945	SENERGY PETROLEUM	383212	GAS/DIESEL	09/14/2017	513.61	513.61	09/21/2017
1818	STOTZ EQUIPMENT	P29059	CHAIN OIL	09/25/2017	15.84	15.84	09/28/2017
6294	WESTERN REFINING WHOLES	309418CT	RED DYE	08/31/2017	798.97	798.97	09/13/2017
Total 10-84-555:					1,328.42	1,328.42	
<b>10-84-590</b>							
2320	CHASE CARD SERVICES	081717/PIZZA	R&R PIZZA	08/17/2017	113.35	113.35	09/13/2017
3350	CURTIS LANDSCAPE & IRRIGAT	21518	GATORADE	08/23/2017	20.46	20.46	09/06/2017
3350	CURTIS LANDSCAPE & IRRIGAT	21545	STRAW HAT	08/30/2017	14.17	14.17	09/13/2017
4645	HOME DEPOT CREDIT SERVIC	74436	ANT BAIT	07/12/2017	23.09	23.09	09/06/2017
4645	HOME DEPOT CREDIT SERVIC	9074995	GLUE TRAPS	08/02/2017	8.66	8.66	09/06/2017
5530	MACK'S AUTO SUPPLY	819315	GLASSES	08/21/2017	13.07	13.07	09/06/2017
7795	TRACTOR SUPPLY CREDIT PLA	200182167	MINI TWIN GALLON	08/22/2017	163.63	163.63	09/13/2017
8245	WALMART COMMUNITY/GEMB	009327-2	BENADRYL	07/31/2017	16.71	16.71	09/06/2017
Total 10-84-590:					373.14	373.14	
<b>10-84-667</b>							
1818	STOTZ EQUIPMENT	P29023	3LB ROUND	09/21/2017	41.45	41.45	09/28/2017
Total 10-84-667:					41.45	41.45	
<b>10-84-741</b>							
1818	STOTZ EQUIPMENT	P28358	WEED EATER	08/01/2017	349.07	349.07	09/06/2017
Total 10-84-741:					349.07	349.07	
<b>10-85-310</b>							
8050	CENTURY LINK	928428511085	TELEPHONE	08/22/2017	.07	.07	09/13/2017
4364	IMPACT TELECOM	608591142	LONG DISTANCE	09/10/2017	2.60	2.60	09/21/2017
8130	VALLEY TELECOM	33664-002/092	TELEPHONE	09/20/2017	88.89	88.89	09/28/2017
Total 10-85-310:					91.56	91.56	
<b>10-85-311</b>							
7827	TRANSWORLD NETWORK COR	14157808-A9	INTERNET	09/16/2017	8.23	8.23	09/28/2017
7827	TRANSWORLD NETWORK COR	14162692-A10	INTERNET	09/22/2017	4.45	4.45	09/28/2017
8195	VERIZON WIRELESS	9791726905	AIR CARDS/CELL	08/26/2017	141.08	141.08	09/06/2017
Total 10-85-311:					153.76	153.76	

Vendor	Vendor Name	Invoice Number	Description	Invoice Date	Net Invoice Amount	Amount Paid	Date Paid
<b>10-85-344</b>							
3850	EASTERN ARIZONA COURIER	1708000630	PRINTING & ADVERTISING	08/31/2017	9.30	9.30	09/13/2017
3850	EASTERN ARIZONA COURIER	1708000998	PRINTING & ADVERTISING	08/31/2017	146.78	146.78	09/13/2017
5080	MCMURRAY COMMUNICATIONS	LOCAL SPORT	PRINTING & ADVERTISING	08/31/2017	19.90	19.90	09/13/2017
Total 10-85-344:					175.98	175.98	
<b>10-85-505</b>							
6250	PETTY CASH	072017	SEAGO TAC	07/20/2017	11.00	11.00	09/21/2017
Total 10-85-505:					11.00	11.00	
<b>10-85-540</b>							
2320	CHASE CARD SERVICES	081117	AMAZON	08/11/2017	42.24	42.24	09/13/2017
6520	QUILL CORPORATION	008745018	OFFICE SUPPLIES	08/02/2017	6.37	6.37	09/28/2017
6520	QUILL CORPORATION	1022600	OFFICE SUPPLIES	09/20/2017	12.55	12.55	09/28/2017
6520	QUILL CORPORATION	9493061	OFFICE SUPPLIES	08/30/2017	7.46	7.46	09/13/2017
6520	QUILL CORPORATION	9498465	OFFICE SUPPLIES	08/31/2017	7.27	7.27	09/13/2017
6520	QUILL CORPORATION	9981679	OFFICE SUPPLIES	09/19/2017	14.04	14.04	09/28/2017
6520	QUILL CORPORATION	9984123	OFFICE SUPPLIES	09/19/2017	.11	.11	09/28/2017
6520	QUILL CORPORATION	9990490	OFFICE SUPPLIES	09/20/2017	4.57	4.57	09/28/2017
Total 10-85-540:					94.61	94.61	
<b>10-85-555</b>							
7945	SENERGY PETROLEUM	383212	GAS/DIESEL	09/14/2017	131.40	131.40	09/21/2017
Total 10-85-555:					131.40	131.40	
<b>10-85-747</b>							
2320	CHASE CARD SERVICES	082117	CBI	08/21/2017	85.27	85.27	09/13/2017
2320	CHASE CARD SERVICES	082117MICRO	MICROSOFT	08/21/2017	218.19	218.19	09/13/2017
2320	CHASE CARD SERVICES	082317	CBI	08/23/2017	38.17	38.17	09/13/2017
Total 10-85-747:					341.63	341.63	
<b>10-85-748</b>							
2320	CHASE CARD SERVICES	08/09APPLE	HEATH-LAPTOP	08/09/2017	1,474.97	1,474.97	09/13/2017
Total 10-85-748:					1,474.97	1,474.97	
<b>10-87-850</b>							
4867	J C G TECHNOLOGIES	5819	SUPPORT SERVICES PACKAGE	06/01/2017	458.79	458.79	09/21/2017
Total 10-87-850:					458.79	458.79	
<b>10-87-852</b>							
2039	ARIZONA BAG COMPANY	3964	BACKSTOP NET	11/22/2016	867.25	867.25	09/21/2017
2035	ARIZONA WATERWORKS SUPP	051044	VALVE BOX	08/10/2017	2,246.51	2,246.51	09/06/2017
6880	SAFFORD BUILDERS SUPPLY C	737265	REBAR	08/23/2017	662.94	662.94	09/06/2017
7820	TRI COUNTY MATERIALS INC	73092	CONCRETE	08/29/2017	911.43	911.43	09/13/2017
7820	TRI COUNTY MATERIALS INC	73093	CONCRETE	08/29/2017	911.43	911.43	09/13/2017
Total 10-87-852:					5,599.56	5,599.56	
<b>10-87-865</b>							
6830	RYLEY CARLOCK & APPLEWHI	275239	ATTORNEY	09/11/2017	797.00	797.00	09/21/2017

Vendor	Vendor Name	Invoice Number	Description	Invoice Date	Net Invoice Amount	Amount Paid	Date Paid
Total 10-87-865:					797.00	797.00	
<b>20-80-770</b>							
4645	HOME DEPOT CREDIT SERVIC	5031104	PIPE WRAP	07/17/2017	62.34	62.34	09/06/2017
Total 20-80-770:					62.34	62.34	
<b>30-75-801</b>							
7075	SEAGO	135-17/082917	TAAP	08/29/2017	4,000.00	4,000.00	09/06/2017
Total 30-75-801:					4,000.00	4,000.00	
<b>30-75-825</b>							
4000	EMPIRE SOUTHWEST	EMRA0016237	REAY LN DAM/740B TRUCK	08/21/2017	18,639.81	18,639.81	09/06/2017
4000	EMPIRE SOUTHWEST	EMRA0016254	REAY LN DAM/D8T DOZER	08/22/2017	21,527.87	21,527.87	09/06/2017
4000	EMPIRE SOUTHWEST	EMRA0016254	REAY LN DAM/740B TRUCK	08/22/2017	15,650.75	15,650.75	09/06/2017
4000	EMPIRE SOUTHWEST	EMRA0016254	REAY LN DAM/740B TRUCK	08/22/2017	17,604.72	17,604.72	09/06/2017
4000	EMPIRE SOUTHWEST	EMRA0016254	REAY LN DAM/740B TRUCK	08/22/2017	16,305.27	16,305.27	09/06/2017
4000	EMPIRE SOUTHWEST	EMRA0016265	REAY LN DAM/980M LOADER	08/23/2017	18,422.61	18,422.61	09/06/2017
4000	EMPIRE SOUTHWEST	EMWK258367	REAY LN DAM/RED DIESEL	08/25/2017	19,639.29	19,639.29	09/06/2017
Total 30-75-825:					127,790.32	127,790.32	
<b>45-83-334</b>							
4302	CITY OF SAFFORD	01-432.01/0831	LANDFILL	08/31/2017	9,754.78	9,754.78	09/13/2017
Total 45-83-334:					9,754.78	9,754.78	
<b>45-83-341</b>							
3800	EASTERN ARIZONA AG CENTE	CS90874	FITTING	09/06/2017	258.45	258.45	09/13/2017
6070	OPEN LOOP ENERGY, INC.	116783	GARBAGE TRUCK	07/26/2017	1,739.65	1,739.65	09/06/2017
5526	RWC INTERNATIONAL, LTD	114659T	KT CAP KIT	09/21/2017	55.45	55.45	09/28/2017
Total 45-83-341:					2,053.55	2,053.55	
<b>45-83-541</b>							
2210	CLASS C SOLUTIONS GROUP	1484015001	NUTS & BOLTS	08/31/2017	106.74	106.74	09/13/2017
2210	CLASS C SOLUTIONS GROUP	1484015004	NUTS & BOLTS	09/01/2017	6.67	6.67	09/13/2017
Total 45-83-541:					113.41	113.41	
<b>45-83-553</b>							
2545	BIG O TIRES	23365	MOUNT	07/27/2017	299.69	299.69	09/06/2017
2545	BIG O TIRES	23374	MOUNT	07/27/2017	313.22	313.22	09/06/2017
2545	BIG O TIRES	23422	MOUNT	07/28/2017	720.81	720.81	09/06/2017
Total 45-83-553:					1,333.72	1,333.72	
<b>45-83-555</b>							
3075	FIRST CALL AUTO PARTS	EB28511411	VEHICLE MAINTENANCE SUPP	07/25/2017	6.67-	6.67-	09/06/2017
3075	FIRST CALL AUTO PARTS	EB30394411	VEHICLE MAINTENANCE SUPP	08/23/2017	6.13-	6.13-	09/06/2017
7945	SENERGY PETROLEUM	383212	GAS/DIESEL	09/14/2017	29.24	29.24	09/21/2017
Total 45-83-555:					16.44	16.44	
<b>50-86-150</b>							
1930	ARIZONA STATE PRISON - SAF	S01111170830	LABOR	09/05/2017	56.25	56.25	09/13/2017

Vendor	Vendor Name	Invoice Number	Description	Invoice Date	Net Invoice Amount	Amount Paid	Date Paid
1930	ARIZONA STATE PRISON - SAF	S01111170914	LABOR	09/18/2017	45.00	45.00	09/21/2017
1930	ARIZONA STATE PRISON - SAF	TOT18-04	LABOR	09/05/2017	7.32	7.32	09/13/2017
1930	ARIZONA STATE PRISON - SAF	TOT18-05	LABOR	09/18/2017	6.39	6.39	09/21/2017
Total 50-86-150:					114.96	114.96	
<b>50-86-310</b>							
8050	CENTURY LINK	928428511085	TELEPHONE	08/22/2017	.03	.03	09/13/2017
4364	IMPACT TELECOM	608591142	LONG DISTANCE	09/10/2017	1.30	1.30	09/21/2017
8130	VALLEY TELECOM	33664-002/092	TELEPHONE	09/20/2017	44.45	44.45	09/28/2017
Total 50-86-310:					45.78	45.78	
<b>50-86-311</b>							
7827	TRANSWORLD NETWORK COR	14157808-A9	INTERNET	09/16/2017	1.40	1.40	09/28/2017
7827	TRANSWORLD NETWORK COR	14162692-A10	INTERNET	09/22/2017	.76	.76	09/28/2017
8195	VERIZON WIRELESS	9791726905	AIR CARDS/CELL	08/26/2017	24.05	24.05	09/06/2017
Total 50-86-311:					26.21	26.21	
<b>50-86-325</b>							
2170	ARIZ DEPT OF ENVIRONMENTA	0000265381X	ANNUAL FEE FOR APP	07/21/2017	2,500.00	2,500.00	09/06/2017
3110	CITY OF PHOENIX	400848281/2	BI SYSTEM USE	07/13/2017	275.00	275.00	09/13/2017
3333	CSHQA	30205	TOWN LAKE CONCEPT	09/01/2017	7,000.00	7,000.00	09/13/2017
Total 50-86-325:					9,775.00	9,775.00	
<b>50-86-347</b>							
2905	CASELLE, INC.	82645	SOFTWARE SUPPORT	09/01/2017	341.25	341.25	09/06/2017
Total 50-86-347:					341.25	341.25	
<b>50-86-520</b>							
4184	FREEDOM MAILING SERVICES,	32011	OUTSOURCE BILLING	09/06/2017	108.23	108.23	09/13/2017
Total 50-86-520:					108.23	108.23	
<b>50-86-533</b>							
4645	HOME DEPOT CREDIT SERVIC	1012870	RIDGID SAW	07/31/2017	129.83	129.83	09/06/2017
7903	HUGHES SUPPLY	S151040398.0	PVC SW ADAPT	09/11/2017	173.09	173.09	09/21/2017
Total 50-86-533:					302.92	302.92	
<b>50-86-537</b>							
4125	FERTIZONA - THATCHER, LLC	19019285	HYVAR	09/26/2017	879.45	879.45	09/28/2017
Total 50-86-537:					879.45	879.45	
<b>50-86-541</b>							
2210	CLASS C SOLUTIONS GROUP	1484015001	NUTS & BOLTS	08/31/2017	34.16	34.16	09/13/2017
2210	CLASS C SOLUTIONS GROUP	1484015004	NUTS & BOLTS	09/01/2017	2.13	2.13	09/13/2017
Total 50-86-541:					36.29	36.29	
<b>50-86-553</b>							
3765	EAST PENN MANUFACTURING	5835375	CORE	08/11/2017	428.95	428.95	09/06/2017

Vendor	Vendor Name	Invoice Number	Description	Invoice Date	Net Invoice Amount	Amount Paid	Date Paid
Total 50-86-553:					428.95	428.95	
<b>50-86-555</b>							
3075	FIRST CALL AUTO PARTS	EB28511411	VEHICLE MAINTENANCE SUPP	07/25/2017	.00	.00	
3075	FIRST CALL AUTO PARTS	EB30394411	VEHICLE MAINTENANCE SUPP	08/23/2017	.00	.00	
7945	SENERGY PETROLEUM	383212	GAS/DIESEL	09/14/2017	145.40	145.40	09/21/2017
7314	SOUTHWESTERN BG, INC	47859	FUELS	09/19/2017	103.66	103.66	09/28/2017
Total 50-86-555:					249.06	249.06	
<b>50-86-571</b>							
7903	HUGHES SUPPLY	S151040398.0	ADAPT SLEEVE	09/11/2017	55.45	55.45	09/21/2017
Total 50-86-571:					55.45	55.45	
<b>50-86-590</b>							
4645	HOME DEPOT CREDIT SERVIC	9062380	POLY ROPE	08/02/2017	72.16	72.16	09/06/2017
8120	UNITED RENTALS(N. AMERICA)	150272923-00	RENTAL	09/18/2017	60.92	60.92	09/28/2017
Total 50-86-590:					133.08	133.08	
<b>50-86-667</b>							
4125	FERTIZONA - THATCHER, LLC	19019141	GLYSTAR PLUS	09/12/2017	460.51	460.51	09/21/2017
Total 50-86-667:					460.51	460.51	
<b>50-86-748</b>							
3435	DAN MARTIN	6023	IT CONSULTING	09/05/2017	360.00	360.00	09/13/2017
Total 50-86-748:					360.00	360.00	
<b>50-86-775</b>							
3145	CKC MATERIALS DIVISION	C1280	PSI	08/31/2017	202.54	202.54	09/13/2017
7820	TRI COUNTY MATERIALS INC	M31682	COLD MIX	08/09/2017	315.64	315.64	09/13/2017
Total 50-86-775:					518.18	518.18	
<b>55-20210</b>							
1600	ARIZ DEPT OF REVENUE-TPT	AUG2017	SALES TAXES	09/12/2017	27,703.69	27,703.69	09/13/2017
Total 55-20210:					27,703.69	27,703.69	
<b>55-21350</b>							
9208	HOPE LOFGREEN	092117	DEPOSIT REFUND	09/21/2017	80.00	80.00	09/28/2017
10055	SELU KULA	083117	DEPOSIT REFUND	08/31/2017	78.14	78.14	09/06/2017
10121	VAKHTANG MATSKHONASHVILI	091317	DEPOSIT REFUND	09/13/2017	46.11	46.11	09/21/2017
Total 55-21350:					204.25	204.25	
<b>55-33-800</b>							
6250	PETTY CASH	092017	SHORT	09/20/2017	.99	.99	09/21/2017
Total 55-33-800:					.99	.99	
<b>55-88-150</b>							
1930	ARIZONA STATE PRISON - SAF	S01111170830	LABOR	09/05/2017	60.00	60.00	09/13/2017
1930	ARIZONA STATE PRISON - SAF	S01111170914	LABOR	09/18/2017	52.50	52.50	09/21/2017

Vendor	Vendor Name	Invoice Number	Description	Invoice Date	Net Invoice Amount	Amount Paid	Date Paid
1930	ARIZONA STATE PRISON - SAF	TOT18-04	LABOR	09/05/2017	7.31	7.31	09/13/2017
1930	ARIZONA STATE PRISON - SAF	TOT18-05	LABOR	09/18/2017	6.40	6.40	09/21/2017
Total 55-88-150:					126.21	126.21	
<b>55-88-310</b>							
8050	CENTURY LINK	928428511085	TELEPHONE	08/22/2017	.11	.11	09/13/2017
4364	IMPACT TELECOM	608591142	LONG DISTANCE	09/10/2017	3.85	3.85	09/21/2017
8130	VALLEY TELECOM	33664-002/092	TELEPHONE	09/20/2017	132.13	132.13	09/28/2017
Total 55-88-310:					136.09	136.09	
<b>55-88-311</b>							
7827	TRANSWORLD NETWORK COR	14157808-A9	INTERNET	09/16/2017	8.24	8.24	09/28/2017
7827	TRANSWORLD NETWORK COR	14162692-A10	INTERNET	09/22/2017	4.45	4.45	09/28/2017
8195	VERIZON WIRELESS	9791726905	AIR CARDS/CELL	08/26/2017	139.48	139.48	09/06/2017
Total 55-88-311:					152.17	152.17	
<b>55-88-325</b>							
5235	K.R. SALINE & ASSOCIATES, PL	TCH311	CONSULTING SERVICES	08/31/2017	1,055.43	1,055.43	09/13/2017
Total 55-88-325:					1,055.43	1,055.43	
<b>55-88-341</b>							
5530	MACK'S AUTO SUPPLY	822748	FUEL PUMP ASSY	09/20/2017	430.56	430.56	09/28/2017
5530	MACK'S AUTO SUPPLY	822792	35 TON SERVICE JACK	09/20/2017	379.22	379.22	09/28/2017
Total 55-88-341:					809.78	809.78	
<b>55-88-344</b>							
3850	EASTERN ARIZONA COURIER	1708000630	PRINTING & ADVERTISING	08/31/2017	6.50	6.50	09/13/2017
3850	EASTERN ARIZONA COURIER	1708000998	PRINTING & ADVERTISING	08/31/2017	102.73	102.73	09/13/2017
5080	MCMURRAY COMMUNICATIONS	LOCAL SPORT	PRINTING & ADVERTISING	08/31/2017	13.93	13.93	09/13/2017
Total 55-88-344:					123.16	123.16	
<b>55-88-347</b>							
2905	CASELLE, INC.	82645	SOFTWARE SUPPORT	09/01/2017	341.25	341.25	09/06/2017
Total 55-88-347:					341.25	341.25	
<b>55-88-381</b>							
7355	ARIZONA ELECTRIC POWER C	AUGUST 2017	TRANSMISSION SERVICES	09/11/2017	26,544.48	26,544.48	09/21/2017
4406	GRAHAM CO UTILITIES	AUGUST 2017	WHEELING	09/13/2017	113,471.00	113,471.00	09/21/2017
8005	US DEPARTMENT OF ENERGY	GG1229B0817	FIRM TRANSMISSION SERVICE	09/05/2017	2,250.00	2,250.00	09/06/2017
Total 55-88-381:					142,265.48	142,265.48	
<b>55-88-385</b>							
1885	ARIZONA POWER AUTHORITY	OY2017-0837	MONTHLY ENERGY BILL	09/08/2017	5,493.28	5,493.28	09/13/2017
2728	BUREAU OF RECLAMATION	90567361	ADVANCE FUNDS CONTRACT	09/15/2017	6,151.79	6,151.79	09/21/2017
7333	SOUTHWEST PUBLIC POWER	1561	PURCHASE OF POWER	09/23/2017	169,857.58	169,857.58	09/28/2017
7677	THE BANK OF NEW YORK TRU	92717.18	LOWER COLORADO	09/01/2017	258.68	258.68	09/13/2017
8005	US DEPARTMENT OF ENERGY	979577	POINT TO POINT TRANSMISSIO	09/01/2017	561.99	561.99	09/13/2017
8005	US DEPARTMENT OF ENERGY	JJPB1229A081	PURCHASE OF POWER	09/14/2017	5,807.23	5,807.23	09/21/2017

Vendor	Vendor Name	Invoice Number	Description	Invoice Date	Net Invoice Amount	Amount Paid	Date Paid
Total 55-88-385:					188,130.55	188,130.55	
<b>55-88-520</b>							
4184	FREEDOM MAILING SERVICES,	32011	OUTSOURCE BILLING	09/06/2017	108.23	108.23	09/13/2017
6052	ON LINE COLLECTIONS	206600000086	COMMISSION ON COLLECTED	09/05/2017	107.95	107.95	09/06/2017
Total 55-88-520:					216.18	216.18	
<b>55-88-525</b>							
2780	BYRAM LABORATORIES	29627	AMR DATA TRANSFERS	09/01/2017	749.70	749.70	09/13/2017
Total 55-88-525:					749.70	749.70	
<b>55-88-533</b>							
2531	BORDER STATES ELECTRIC SU	913172416	PUNCH SET	06/06/2017	370.56	370.56	09/21/2017
4645	HOME DEPOT CREDIT SERVIC	1031833	PVC ADAPTER	07/31/2017	21.88	21.88	09/06/2017
4645	HOME DEPOT CREDIT SERVIC	31888	GROUT	08/01/2017	15.22	15.22	09/06/2017
4645	HOME DEPOT CREDIT SERVIC	4573895	HOLE STRAP	08/07/2017	51.86	51.86	09/06/2017
8245	WALMART COMMUNITY/GEMB	003646	AIR PRO	09/07/2017	5.46	5.46	09/28/2017
8245	WALMART COMMUNITY/GEMB	005587	AIR PRO	09/07/2017	52.11	52.11	09/28/2017
Total 55-88-533:					517.09	517.09	
<b>55-88-535</b>							
4184	FREEDOM MAILING SERVICES,	32011	POSTAGE	09/06/2017	601.19	601.19	09/13/2017
6250	PETTY CASH	072517	POSTAGE	07/25/2017	.58	.58	09/21/2017
6250	PETTY CASH	081017	POSTAGE	08/10/2017	47.50	47.50	09/21/2017
6250	PETTY CASH	081717	POSTAGE	08/17/2017	12.62	12.62	09/21/2017
6250	PETTY CASH	091117	POSTAGE	09/11/2017	47.50	47.50	09/21/2017
6250	PETTY CASH	091417	POSTAGE	09/14/2017	26.50	26.50	09/21/2017
Total 55-88-535:					735.89	735.89	
<b>55-88-540</b>							
6520	QUILL CORPORATION	008745018	OFFICE SUPPLIES	08/02/2017	6.37	6.37	09/28/2017
6520	QUILL CORPORATION	1022600	OFFICE SUPPLIES	09/20/2017	12.55	12.55	09/28/2017
6520	QUILL CORPORATION	9493061	OFFICE SUPPLIES	08/30/2017	7.46	7.46	09/13/2017
6520	QUILL CORPORATION	9498465	OFFICE SUPPLIES	08/31/2017	7.27	7.27	09/13/2017
6520	QUILL CORPORATION	9981679	OFFICE SUPPLIES	09/19/2017	14.04	14.04	09/28/2017
6520	QUILL CORPORATION	9984123	OFFICE SUPPLIES	09/19/2017	.11	.11	09/28/2017
6520	QUILL CORPORATION	9990490	OFFICE SUPPLIES	09/20/2017	4.57	4.57	09/28/2017
Total 55-88-540:					52.37	52.37	
<b>55-88-541</b>							
2210	CLASS C SOLUTIONS GROUP	1484015001	NUTS & BOLTS	08/31/2017	38.40	38.40	09/13/2017
2210	CLASS C SOLUTIONS GROUP	1484015004	NUTS & BOLTS	09/01/2017	2.40	2.40	09/13/2017
4645	HOME DEPOT CREDIT SERVIC	9043421	WISS MAX CUT	08/02/2017	46.72	46.72	09/06/2017
Total 55-88-541:					87.52	87.52	
<b>55-88-542</b>							
4645	HOME DEPOT CREDIT SERVIC	5012785	CONCRETE MIX	07/27/2017	28.37	28.37	09/06/2017
Total 55-88-542:					28.37	28.37	

Vendor	Vendor Name	Invoice Number	Description	Invoice Date	Net Invoice Amount	Amount Paid	Date Paid
<b>55-88-550</b>							
5950	NCE MANAGEMENT TRUST	57825	KEYS	08/18/2017	3.00	3.00	09/13/2017
5950	NCE MANAGEMENT TRUST	57930	KEYS	09/07/2017	6.00	6.00	09/13/2017
Total 55-88-550:					9.00	9.00	
<b>55-88-553</b>							
5530	MACK'S AUTO SUPPLY	805409	TXREEL	05/01/2017	98.39	98.39	09/13/2017
Total 55-88-553:					98.39	98.39	
<b>55-88-555</b>							
3075	FIRST CALL AUTO PARTS	EB28511411	VEHICLE MAINTENANCE SUPP	07/25/2017	.00	.00	
3075	FIRST CALL AUTO PARTS	EB30394411	VEHICLE MAINTENANCE SUPP	08/23/2017	.00	.00	
7945	SENERGY PETROLEUM	383212	GAS/DIESEL	09/14/2017	243.02	243.02	09/21/2017
7314	SOUTHWESTERN BG, INC	47683	BRAKE CLEANER	08/08/2017	241.74	241.74	09/06/2017
Total 55-88-555:					484.76	484.76	
<b>55-88-748</b>							
3435	DAN MARTIN	6023	IT CONSULTING	09/05/2017	360.00	360.00	09/13/2017
Total 55-88-748:					360.00	360.00	
<b>55-88-760</b>							
2531	BORDER STATES ELECTRIC SU	912902167	500SP	04/18/2017	490.66	490.66	09/21/2017
2531	BORDER STATES ELECTRIC SU	913099795	PVC CONDUIT	05/23/2017	360.52	360.52	09/21/2017
4406	GRAHAM CO UTILITIES	W/O AUG 2017	BART CARTER/REAY LN	09/14/2017	11,340.61	11,340.61	09/28/2017
4406	GRAHAM CO UTILITIES	W/O AUG 2017	BOYD BRYCE/WRECKING YAR	09/14/2017	5,572.89	5,572.89	09/28/2017
Total 55-88-760:					17,764.68	17,764.68	
<b>55-88-780</b>							
4645	HOME DEPOT CREDIT SERVIC	2031233	TOTE	07/20/2017	7.60	7.60	09/06/2017
Total 55-88-780:					7.60	7.60	
<b>55-88-781</b>							
4645	HOME DEPOT CREDIT SERVIC	3580827	BREAKER TEST	07/19/2017	42.34	42.34	09/06/2017
5530	MACK'S AUTO SUPPLY	817765	MARKERS	08/08/2017	34.04	34.04	09/06/2017
Total 55-88-781:					76.38	76.38	
<b>55-88-782</b>							
4645	HOME DEPOT CREDIT SERVIC	8573780	STRETCH WRAP	08/03/2017	39.24	39.24	09/06/2017
Total 55-88-782:					39.24	39.24	
<b>55-88-784</b>							
2531	BORDER STATES ELECTRIC SU	913374541	ELECTRIC	07/13/2017	101.15	101.15	09/21/2017
2830	C E S SAFFORD	SAF/035414	WP BOX	08/29/2017	110.60	110.60	09/13/2017
4645	HOME DEPOT CREDIT SERVIC	4074629	SPRING CLAMP	07/18/2017	39.81	39.81	09/06/2017
4645	HOME DEPOT CREDIT SERVIC	42005	GERMICIDAL BLEACH	07/12/2017	10.41	10.41	09/06/2017
4645	HOME DEPOT CREDIT SERVIC	5031621	COUPLING	07/27/2017	43.94	43.94	09/06/2017
4645	HOME DEPOT CREDIT SERVIC	5074575	PRE MIX FUEL	07/17/2017	32.64	32.64	09/06/2017
4645	HOME DEPOT CREDIT SERVIC	6083378	METAL DC WHEEL	07/26/2017	39.63	39.63	09/06/2017



---

Vendor	Vendor Name	Invoice Number	Description	Invoice Date	Net Invoice Amount	Amount Paid	Date Paid
Total 55-88-784:					378.18	378.18	
Grand Totals:					680,553.80	680,553.80	

---

Dated: \_\_\_\_\_

Mayor: \_\_\_\_\_

Vice Mayor: \_\_\_\_\_

Town Council: \_\_\_\_\_

\_\_\_\_\_

\_\_\_\_\_

\_\_\_\_\_

\_\_\_\_\_

Depty Clerk: \_\_\_\_\_

---

Report Criteria:

- Detail report.
  - Invoices with totals above \$0.00 included.
  - Only paid invoices included.
-

TOWN OF THATCHER  
FUND SUMMARY  
FOR THE 3 MONTHS ENDING SEPTEMBER 30, 2017

GENERAL FUND

	PERIOD ACTUAL	YTD ACTUAL	BUDGET	VARIANCE	PCNT
<u>REVENUE</u>					
TOWN TAXES	255,535.67	817,802.18	3,000,000.00	2,182,197.82	27.3
INTERGOVERNMENTAL REVENUE	129,874.18	361,465.17	1,411,051.00	1,049,585.83	25.6
CHARGES FOR SERVICES	6,749.82	24,575.34	167,500.00	142,924.66	14.7
LICENSES/PERMITS	6,033.50	15,641.00	17,050.00	1,409.00	91.7
FINES/FOREITS	.00	.00	50.00	50.00	.0
MISCELLANEOUS	3,255.56	3,245.67	26,200.00	22,954.33	12.4
INTEREST ON INVESTMENTS	8,786.40	24,092.24	35,000.00	10,907.76	68.8
SOURCE 39	.00	.00	.00	.00	.0
	<u>410,235.13</u>	<u>1,246,821.60</u>	<u>4,656,851.00</u>	<u>3,410,029.40</u>	<u>26.8</u>
<u>EXPENDITURES</u>					
MAYOR AND COUNCIL	27,062.26	54,807.73	247,699.00	192,891.27	22.1
ADMINISTRATION	23,182.91	73,386.97	279,922.00	206,535.03	26.2
MAGISTRATE	10,396.03	31,890.02	112,868.00	80,977.98	28.3
COMMUNITY DEVELOPMENT	.00	.00	.00	.00	.0
PARKS/RECREATION	26,943.09	143,463.52	450,110.00	306,646.48	31.9
POLICE	130,978.54	665,839.24	2,099,072.00	1,433,232.76	31.7
FIRE	27,141.98	46,237.08	122,825.00	76,587.92	37.6
SHOP	28,470.91	84,497.98	280,484.00	195,986.02	30.1
SANITATION	.00	.00	.00	.00	.0
STREETS	52,718.19	157,876.53	673,503.00	515,626.47	23.4
COMMUNITY DEVELOPMENT	26,764.21	98,729.42	379,739.00	281,009.58	26.0
MISCELLANEOUS EXPENSES	6,855.35	( 1,452.42)	4,195,500.00	4,196,952.42	.0
	<u>360,513.47</u>	<u>1,355,276.07</u>	<u>8,841,722.00</u>	<u>7,486,445.93</u>	<u>15.3</u>
	<u>49,721.66</u>	<u>( 108,454.47)</u>	<u>( 4,184,871.00)</u>	<u>( 4,076,416.53)</u>	<u>( 2.6)</u>

TOWN OF THATCHER  
 FUND SUMMARY  
 FOR THE 3 MONTHS ENDING SEPTEMBER 30, 2017

HURF FUND

	PERIOD ACTUAL	YTD ACTUAL	BUDGET	VARIANCE	PCNT
<u>REVENUE</u>					
INTERGOVERNMENTAL REVENUE	41,873.51	106,479.51	421,611.00	315,131.49	25.3
INTEREST ON INVESTMENTS	.66	1.81	.00	( 1.81)	.0
	<u>41,874.17</u>	<u>106,481.32</u>	<u>421,611.00</u>	<u>315,129.68</u>	<u>25.3</u>
<u>EXPENDITURES</u>					
SPECIAL REVENUE EXPENDITURES	62.34	42,519.43	421,611.00	379,091.57	10.1
DEPARTMENT 87	.00	.00	.00	.00	.0
	<u>62.34</u>	<u>42,519.43</u>	<u>421,611.00</u>	<u>379,091.57</u>	<u>10.1</u>
	<u><u>41,811.83</u></u>	<u><u>63,961.89</u></u>	<u><u>.00</u></u>	<u><u>( 63,961.89)</u></u>	<u><u>.0</u></u>

TOWN OF THATCHER  
 FUND SUMMARY  
 FOR THE 3 MONTHS ENDING SEPTEMBER 30, 2017

LTAF FUND

	<u>PERIOD ACTUAL</u>	<u>YTD ACTUAL</u>	<u>BUDGET</u>	<u>VARIANCE</u>	<u>PCNT</u>
<u>REVENUE</u>					
INTERGOVERNMENTAL REVENUE	.00	.00	.00	.00	.0
INTEREST ON INVESTMENTS	.00	.00	.00	.00	.0
	<u>.00</u>	<u>.00</u>	<u>.00</u>	<u>.00</u>	<u>.0</u>
<u>EXPENDITURES</u>					
SPECIAL REVENUE EXPENDITURES	.00	.00	.00	.00	.0
	<u>.00</u>	<u>.00</u>	<u>.00</u>	<u>.00</u>	<u>.0</u>
	<u>.00</u>	<u>.00</u>	<u>.00</u>	<u>.00</u>	<u>.0</u>

TOWN OF THATCHER  
 FUND SUMMARY  
 FOR THE 3 MONTHS ENDING SEPTEMBER 30, 2017

MISCELLANEOUS GRANTS

	<u>PERIOD ACTUAL</u>	<u>YTD ACTUAL</u>	<u>BUDGET</u>	<u>VARIANCE</u>	<u>PCNT</u>
<u>REVENUE</u>					
INTERGOVERNMENTAL REVENUE	12,864.25	80,127.55	456,800.00	376,672.45	17.5
SOURCE 37	.00	.00	.00	.00	.0
	<u>12,864.25</u>	<u>80,127.55</u>	<u>456,800.00</u>	<u>376,672.45</u>	<u>17.5</u>
<u>EXPENDITURES</u>					
POLICE	.00	.00	.00	.00	.0
GRANT-EXPENDITURES	140,459.15	210,588.06	456,800.00	246,211.94	46.1
	<u>140,459.15</u>	<u>210,588.06</u>	<u>456,800.00</u>	<u>246,211.94</u>	<u>46.1</u>
	<u>( 127,594.90)</u>	<u>( 130,460.51)</u>	<u>.00</u>	<u>130,460.51</u>	<u>.0</u>

TOWN OF THATCHER  
 FUND SUMMARY  
 FOR THE 3 MONTHS ENDING SEPTEMBER 30, 2017

IMPROVEMENT DISTRICT FUND

	<u>PERIOD ACTUAL</u>	<u>YTD ACTUAL</u>	<u>BUDGET</u>	<u>VARIANCE</u>	<u>PCNT</u>
<u>REVENUE</u>					
SOURCE 30	.00	.00	.00	.00	.0
	.00	.00	.00	.00	.0
 <u>EXPENDITURES</u>					
	.00	.00	.00	.00	.0
	.00	.00	.00	.00	.0

TOWN OF THATCHER  
 FUND SUMMARY  
 FOR THE 3 MONTHS ENDING SEPTEMBER 30, 2017

SANITATION ENTERPRISE FUND

	PERIOD ACTUAL	YTD ACTUAL	BUDGET	VARIANCE	PCNT
<u>REVENUE</u>					
CHARGES FOR SERVICES	24,490.02	73,662.60	275,000.00	201,337.40	26.8
SOURCE 36	.00	.00	.00	.00	.0
INTEREST ON INVESTMENTS	.00	.00	.00	.00	.0
SOURCE 38	.00	.00	.00	.00	.0
	<u>24,490.02</u>	<u>73,662.60</u>	<u>275,000.00</u>	<u>201,337.40</u>	<u>26.8</u>
<u>EXPENDITURES</u>					
DEPARTMENT 83	<u>20,438.19</u>	<u>77,293.90</u>	<u>297,376.00</u>	<u>220,082.10</u>	<u>26.0</u>
	<u>20,438.19</u>	<u>77,293.90</u>	<u>297,376.00</u>	<u>220,082.10</u>	<u>26.0</u>
	<u>4,051.83</u>	<u>( 3,631.30)</u>	<u>( 22,376.00)</u>	<u>( 18,744.70)</u>	<u>( 16.2)</u>

TOWN OF THATCHER  
 FUND SUMMARY  
 FOR THE 3 MONTHS ENDING SEPTEMBER 30, 2017

SEWER ENTERPRISE FUND

	PERIOD ACTUAL	YTD ACTUAL	BUDGET	VARIANCE	PCNT
<u>REVENUE</u>					
INTERGOVERNMENTAL REVENUE	.00	.00	.00	.00	.0
CHARGES FOR SERVICES	30,254.24	98,375.00	303,000.00	204,625.00	32.5
MISCELLANEOUS	.00	.00	.00	.00	.0
INTEREST ON INVESTMENTS	.00	.00	.00	.00	.0
SOURCE 38	.00	.00	.00	.00	.0
	<u>30,254.24</u>	<u>98,375.00</u>	<u>303,000.00</u>	<u>204,625.00</u>	<u>32.5</u>
 <u>EXPENDITURES</u>					
SEWER	<u>20,302.73</u>	<u>68,104.48</u>	<u>303,000.00</u>	<u>234,895.52</u>	<u>22.5</u>
	<u>20,302.73</u>	<u>68,104.48</u>	<u>303,000.00</u>	<u>234,895.52</u>	<u>22.5</u>
	<u>9,951.51</u>	<u>30,270.52</u>	<u>.00</u>	<u>( 30,270.52)</u>	<u>.0</u>



TOWN OF THATCHER  
 FUND SUMMARY  
 FOR THE 3 MONTHS ENDING SEPTEMBER 30, 2017

ELECTRIC ENTERPRISE FUND

	<u>PERIOD ACTUAL</u>	<u>YTD ACTUAL</u>	<u>BUDGET</u>	<u>VARIANCE</u>	<u>PCNT</u>
<u>REVENUE</u>					
CHARGES FOR SERVICES	677,344.56	1,724,356.68	4,684,356.00	2,959,999.32	36.8
INTEREST ON INVESTMENTS	1,402.27	3,845.03	5,000.00	1,154.97	76.9
	<u>678,746.83</u>	<u>1,728,201.71</u>	<u>4,689,356.00</u>	<u>2,961,154.29</u>	<u>36.9</u>
<u>EXPENDITURES</u>					
ELECTRIC	<u>389,474.62</u>	<u>1,223,204.70</u>	<u>5,689,357.00</u>	<u>4,466,152.30</u>	<u>21.5</u>
	<u>389,474.62</u>	<u>1,223,204.70</u>	<u>5,689,357.00</u>	<u>4,466,152.30</u>	<u>21.5</u>
	<u><u>289,272.21</u></u>	<u><u>504,997.01</u></u>	<u><u>( 1,000,001.00)</u></u>	<u><u>( 1,504,998.01)</u></u>	<u><u>50.5</u></u>