



AGENDA 6:30 PM

TOWN OF THATCHER, TOWN COUNCIL MEETING

MONDAY, AUGUST 21, 2023

Thatcher Town Hall Council Chambers - 3700 West Main St, Thatcher, Arizona

1. Welcome and Call Meeting to Order
2. Pledge of Allegiance
3. Roll Call
4. **PUBLIC HEARING**
5. **OPEN CALL TO THE PUBLIC:**
6. **PUBLIC APPEARANCES:**
7. **CONSENT AGENDA:** Action Item
 - A. Approve Minutes of the July 17, 2023, Regular Council Meeting
 - B. Planning and Zoning Monthly Report
 - C. Police Monthly Report
 - D. Approval of Invoices
 - E. Financial Reports
8. **OLD BUSINESS:** Discussion, consideration, and possible action
9. **NEW BUSINESS:** Discussion, consideration, and possible action
 - A. Engineering Services for Electric Sub-Station Design, T & D Services, \$219,675.00
 - B. Engineering Services for 8th Street Reconstruction Project, EPS Group
 - C. Purchase of Sub-Station Transformer, Pralar, \$692,420.00
 - D. Sewer Main CCTV & Cleaning Contract Extension, BCAC Underground, \$62,038.00
 - E. Town of Thatcher Fee Schedule - Revision

GUIDELINES FOR CITIZEN COMMENTS DURING PUBLIC HEARINGS:

PURPOSE:

- Allow citizens to provide input to the Town Council on a particular subject scheduled on the agenda as a public hearing.
- This is not a question-and-answer session.

PROCEDURES:

- When recognized during the "Public Hearing" section use the microphone.
- Limit comments to 3 minutes.
- State your Name & City of residence

GUIDELINES FOR CITIZEN COMMENTS ON NON-AGENDA ITEMS:

PURPOSE:

- The Thatcher Town Council values citizen comments and input.
- Because these items are not listed on the Council Agenda, Council may not act on the information during the meeting but may refer the matter to the Town Manager for follow-up.

PROCEDURES:

- When recognized during the "Open Call to the Public" section use the microphone.
- Limit comments to 5 minutes.
- State your Name & City of residence

DECLARATION ON CONFLICT OF INTEREST: Council members and staff have a right to declare interest. The declaration of a conflict of interest must be made prior to discussion of any agenda item in which Council Members or staff members determine they have a conflict of interest.

10. INFORMATIONAL ITEMS:

A. Town Manager’s Report

- Public Works Department – Recreation Complex, Empire Driveway, La Casita Landscaping
- Personnel Update
- US 70 Beautification Grant
- 8th Street Widening Grant - Funding
- On-Call Engineering Services – Grant Pursual
- Grant Opportunities – Field Lighting & Little League Field
- Financial Summary
- Police Department
- Fire Department

B. Council Reports

11. FUTURE AGENDA ITEMS & POTENTIAL QUOROM’S

12. ADJOURNMENT

GUIDELINES FOR CITIZEN COMMENTS ON AGENDA ITEMS:

PURPOSE:

-The Thatcher Town Council welcomes citizens to address them in their public meetings and will schedule the subject on the agenda.

PROCEDURES:

- Fill out a “Public Appearance Request” form to address the Town Council and present it to the Town Clerk 7 days prior to the meeting.
- When recognized during the “Public Appearance” section use the microphone.
- Limit comments to 15 minutes.
- State your Name & City of residence

A copy of agenda background material provided to Council members, except for material relating to possible executive sessions, is available for public inspection at the Town Clerk’s office, 3700 W. Main Street, Monday-Thursday 7:00 am – 6:00 pm. The Town Council reserves the right to act upon any item on the agenda. Town Council Meeting Agendas are available on the Town’s website at: www.thatcher.az.gov

NOTES: Pursuant to Title II of the Americans with Disabilities Act (ADA), persons with a disability may request reasonable accommodations by contacting Thatcher Town Hall at (928) 428-2290, forty-eight (48) hours prior to the meeting.

POSTED BY:

DATE:

TIME:



**MEETING MINUTES FOR THE REGULAR MEETING & PUBLIC HEARING
OF THE THATCHER TOWN COUNCIL
JULY 17, 2023**

Councilmembers present: Vice Mayor Howard, Councilwoman Smith, Councilman Welker, Councilman Vining, Councilman Carlton, Councilman McEuen

Councilmembers absent: Mayor Bryce

Staff present: Town Manager Heath Brown, Town Attorney Matt Clifford, Police Chief Shaffen Woods, Interim Fire Chief Steve Curtis, Town Engineer Tom Palmer, Deputy Town Clerk Annie Reidhead, Procurement Officer Gary Allred, Finance Intern Brooklyn Angle

Visitors: County Supervisor John Howard, David Bell (EA Courier), Rue Mattice, Ray Bejarano, Steve Curtis, Ryan Curtis, Jake Ferrin, Curtis Whittle, Dayna Tolman, Matt Petersen, Natasha Petersen, David Rigley, Kirke Goltib, Debbie Turley, Shawn Turley, Todd Rusell

Welcome and Call Meeting to Order at 6:30 p.m. by Vice Mayor Howard and she stated that this is a public meeting of the Thatcher Town Council. She stated that we do have a quorum.

Pledge of Allegiance led by Councilman Welker.

AGENDA

1. **PUBLIC HEARING:** None

2. **OPEN CALL TO THE PUBLIC:** None

3. **PUBLIC APPEARANCES:**

A. Debbie Turley – Pickleball Courts

Debbie Turley asked the council to consider adding additional pickleball courts to the Recreation Complex. She explained how pickleball is becoming more popular and how it is a sport that is bringing the community together. There were lots of supporters in attendance. Mrs. Turley also provided the council with photos.

The council agreed to add this information as an agenda item for the next Work Session meeting.

4. **CONSENT AGENDA:** Action Item

A. Approve Minutes of the June 19, 2023, Regular Council Meeting.

B. Planning and Zoning Monthly Report.

C. Police Monthly Report.

D. Approval of Invoices.

E. Financial Reports.

Vice Mayor Howard asked if Mr. Brown could recap the year-end information from the financial report.

Councilmember Carlton made a motion to approve the Consent Agenda and seconded by Councilmember Welker. Motion carried unanimously.

5. **OLD BUSINESS:**

A. Fire Department Pay per Call / Meetings

Mr. Brown stated that Mayor Bryce and Councilman Vining met with the Fire Department heads to discuss this item in detail. The meeting discussion included talks about paying each firefighter \$20 per call and \$20 per meeting, paying the Fire Chief \$2,000 per month, and discussed increasing the fire pension fund from \$5,000 to \$15,000. Mr. Brown stated that these payments total approximately \$75,000. Councilmember Vining spoke about the condition of the Fire Department building and stated that there are needed improvements, and this should be discussed in the future.

Councilmember Vining made a motion to move \$100,000 out of the contingency fund to pay volunteer firefighters \$20 per call and \$20 per meeting, pay \$25,000 yearly to the Fire Chief, and add \$10,000 to the fire pension fund and seconded by Councilmember McEuen. Motion carried unanimously.

6. NEW BUSINESS: Discussion, consideration, and possible action

A. Approval Extension of Copper Valley Farms Subdivision

Mr. Brown stated that this is the Ben Allred subdivision on Reay Lane that was approved 2 years ago and is in the construction process. Mr. Allred has submitted a letter to the Council to renew the approval.

Councilmember Welker made a motion to approve the extension of Copper Valley Farms Subdivision as discussed and seconded by Councilmember Vining. Motion carried unanimously.

B. Fire Chief Appointment

Mr. Brown announced that the Fire Department has voted and recommended interim Fire Chief Steve Curtis as the new Fire Chief. The Fire Department has asked the Council to consider the recommendation and make the appointment official.

Councilmember Carlton made a motion to appoint Steve Curtis as Fire Department Chief and seconded by Councilmember McEuen. Motion carried unanimously.

C. ADOT IGA 23-0009287 for 8th Street Re-Construction

Mr. Brown stated that this is the IGA between the Town and ADOT for most needed re-construction of 8th Street. ADOT will provide \$4,526,400 in funds and the Town will match the remaining funds to total an amount of \$5 million. Mr. Brown stated that then the Town will reconstruct the road as reported in the application provided to ADOT. The IGA has been reviewed by the Town Attorney Matt Clifford.

Councilmember Carlton made a motion to approve ADOT IGA 23-000987 for 8th Street Re-Construction and seconded by Councilmember McEuen. Motion carried unanimously.

D. Thatcher Unified School Dist. IGA 2023-07-17 for School Resource Officer

Mr. Brown stated that last year the Thatcher Unified School District received a grant that paid this IGA 100%. This year the school did not receive the grant. Thatcher Unified School District has agreed to pay \$50,000 towards the salaries and benefits for the School Resource Officer as stated in the IGA. The school and Town agree this will allow the program to continue, which are both in approval of. Officer Arbizo is designated as the School Resource Officer and when school is not in session he will be designated as a regular officer.

Councilmember Carlton made a motion to approve Thatcher Unified School District IGA 2023-07-17 for School Resource Officer and seconded by Councilmember Smith. Motion carried unanimously.

E. Arizona School Risk Retention Trust, Inc. Facility Use Agreement Between TUSD and the Town of Thatcher

Mr. Brown stated that the Town has used the school's facilities for many years for some of our recreation leagues. There has not been a formal agreement in place for the use of the facilities. The Town would follow the schools' rental rates. This would be approximately \$10,000 for this year. This IGA is based on an annual review and has been reviewed by Town Attorney Matt Clifford. Staff recommends approval of this IGA.

Councilmember Smith made a motion to approve the Arizona School Risk Retention Trust, Inc. Use Agreement between TUSD and the Town of Thatcher and seconded by Councilmember Carlton. Motion carried unanimously.

7. INFORMATIONAL ITEMS:

A. Town Manager's Report

- Public Works Department
Landscape rock and boulders have been placed at the Recreation Complex.

Crews have finished the work on High School Avenue. They have been busy with sewer taps and potholes. They have also finished the fencing on 1st Avenue.

- 4th of July Report
The event went well, and everyone was thanked.
- 8th Street Widening Project Update, ROW
Verbal commitments from everyone
- American Southwest Credit Union Update
Commitment from there is still in place and they will begin moving forward soon.
- Grant Opportunities
Applications have been submitted to United Way for \$200,000 and FMI for \$100,000 towards the soccer field lighting at the Recreation Complex.
The Diamondbacks grant is in process and is due July 31st. These funds will be for baseball field construction at the Platt property.
- Financial Summary
- Reported back information on the 3-day ACMA conference that was last week.
- Police Department
Chief Woods stated that our K9 officer is in training this week. He reported back on the weeklong FBI course he attended in Virginia.
- Fire Department
Chief Curtis thanked the Council for approving the funds for pay outs to the Firefighters. He said they will be doing some house cleaning with their bylaws. Chief Curtis also discussed the recent house burn fires that were done for training purposes. The Chief referred to one of the firefighters for an explanation of the training and how he learned from it.
Josh Curtis announced that the Fire Department was awarded a grant from AgWest Farm Credit for \$100,000 that will be used toward radio equipment.

B. Council Reports

Vice Mayor Howard mentioned that there is more funding that will be available from RTAC and SEAGO.

8. FUTURE AGENDA ITEMS & POTENTIAL QUORUM'S:

The council recommended adding the pickleball court additions and the golf course assistance to the work session agenda.

9. ADJOURNMENT

Councilmember Smith made a motion to adjourn the meeting at 7:30 p.m. and was seconded by Councilmember Welker. Motion carried unanimously.

APPROVED:

Heath Brown, Town Manager

Randy Bryce, Mayor

CERTIFICATION

I hereby certify that the foregoing minutes are a true and correct copy of the minutes of the regular meeting of the Town Council of the Town of Thatcher held on this 17th day of July. I further certify that the meeting was duly called and held and that a quorum was present.

Annie Reidhead, Deputy Clerk

TOWN OF THATCHER BUILDING PERMITS

				Jul-23						
								Number of Permits	Valuation	Number of housing Units
New Residential Buildings										
One-family houses, detached										
one-family houses, attached										
Two-family buildings										
Apartment Three and four family										
Buildings Five or more family										
Manufactured/Mobile Homes/Park Models										
Publicly owned housing units										
Hotels, motels, tourist courts and cabins										
Other shelter										
New Nonresidential Buildings										
Amusement and recreational buildings										
Churches and other religious buildings										
Industrial buildings										
Parking garages open to general public										
Service Stations and Repair Garages										
Hospitals and other institutional buildings										
Office, bank and professional buildings										
Stores and other mercantile buildings										
Public works and utilities buildings, publicly owned										
Public works and utilities buildings, privately owned										
Schools/other educational buildings, publicly owned										
Schools/other educational buildings, privately owned										
Other nonresidential buildings								1	\$ 90,000.00	
Structures other than buildings, Solar PV Systems								2	\$ 20,334.00	
Swimming pools, fences, billboards, signs, awnings, etc.								2	\$ 48,214.00	
Additions and Alterations										
Residential buildings								2	\$ 11,700.00	
Residential garages and carports										
Commercial buildings										
All other buildings and structures										
Total										
Housing unit demolitions										
TOTAL								7	\$ 170,248.00	

Thatcher Police Department Chief's Report
2022

	JAN	FEB	MAR	APR	MAY	JUNE	JULY	AUG	SEP	OCT	NOV	DEC	TOTAL
Complaints Answered	200	209	204	205	228	192	283	321	224	222	280	235	2803
Arrests	8	9	7	14	10	12	26	12	9	8	14	10	139
Juvenile Referrals	2	0	1	2	1	0	3	1	10	8	14	1	43
Traffic Citations	31	17	24	39	51	42	22	31	39	48	41	26	411
Warnings	243	212	218	172	218	211	118	223	108	159	217	134	2233
MONTHLY TOTAL	484	447	454	332	508	457	452	588	390	445	566	406	5529
YEARLY TOTAL	484	931	1385	1717	2225	2682	3134	3722	4112	4557	5123	5529	5529

CURRENT MONTH BREAKDOWN

COMPLAINT BREAKDOWN

						<u>Property</u>	<u>MILES</u>
Accidents	13	Sex Offenses	1	Thefts	5	Stolen	\$ 2038
Traffic Comp	6	Crim Damage	7	Disturbance	1	Recovered	750
Veh Assist	12	Alarm	6	Fire	3	Difference	1288
Domestic	6	Assault	1	Deaths	1		
DUI	6	Animal	2	Juv Comp	4		
Missing Person	0	Drugs	5	Gen Comp	155		
Alcohol Viol	0	Homicide	1				

YEAR TO DATE BREAKDOWN

COMPLAINT BREAKDOWN

						<u>Property</u>	<u>MILES</u>
Accidents	135	Sex Offenses	3	Thefts	48	Stolen	\$ 9398
Traffic Comp	79	Crim Damage	58	Disturbance	26	Recovered	3440
Veh Assist	159	Alarm	94	Fire	32	Difference	5958
Domestic	65	Assault	16	Deaths	7		
DUI	37	Animal	103	Juv Comp	86		
Missing Person	3	Drugs	20	Gen Comp	1905		
Alcohol Viol	17	Homicide	1				

Thatcher Police Department Chief's Report
2023

	JAN	FEB	MAR	APR	MAY	JUNE	JULY	AUG	SEP	OCT	NOV	DEC	TOTAL
Complaints Answered	247	270	275	273	243	241							1549
Arrests	11	9	7	5	10	10							52
Juvenile Referrals	1	3	2	3	3	2							12
Traffic Citations	42	21	18	12	39	29							161
Warnings	181	152	149	155	176	195							1008
MONTHLY TOTAL	482	455	451	448	471	477							2784
YEARLY TOTAL	482	937	1388	1836	2307	2784							2784

CURRENT MONTH BREAKDOWN

COMPLAINT BREAKDOWN

						<u>Property</u>	<u>MILES</u>
Accidents	9	Sex Offenses	2	Thefts	5	Stolen	\$12300 6879
Traffic Comp	3	Crim Damage	4	Disturbance	1	Recovered	0
Veh Assist	10	Alarm	5	Fire	4	Difference	12300
Domestic	4	Assault	3	Deaths	0		
DUI	3	Animal	14	Juv Comp	8		
Missing Person	0	Drugs	1	Gen Comp	165		
Alcohol Viol	0	Homicide	0				

YEAR TO DATE BREAKDOWN

COMPLAINT BREAKDOWN

						<u>Property</u>	<u>MILES</u>
Accidents	70	Sex Offenses	2	Thefts	28	Stolen	\$ 15928 52736
Traffic Comp	34	Crim Damage	22	Disturbance	7	Recovered	0
Veh Assist	73	Alarm	48	Fire	11	Difference	19028
Domestic	34	Assault	10	Deaths	1		
DUI	17	Animal	50	Juv Comp	50		
Missing Person	0	Drugs	14	Gen Comp	1116		
Alcohol Viol	2	Homicide	0				

Report Criteria:

- Detail report.
- Invoices with totals above \$0.00 included.
- Only paid invoices included.

GL Account and Title	Vendor	Vendor Name	Invoice Number	Description	Invoice Date	Net Invoice Amount	Amount Paid	Date Paid
10-20300 MEDICAL INSURANCE PAYABLE								
10-20300 MEDICAL INSURANCE PAYA	2077	ASSURITY LIFE INSURANCE C	4004010913	ACCIDENT INSURANCE	07/20/2023	5,189.74	5,189.74	07/19/2023
Total 10-20300 MEDICAL INSURANCE PAYABLE:						5,189.74	5,189.74	
10-20320 JCEF PAYABLE								
10-20320 JCEF PAYABLE	10139	ANGELA LATTERI	CM202100000	RESTITUTION	07/05/2023	25.00	25.00	07/06/2023
10-20320 JCEF PAYABLE	1960	ARIZONA STATE TREASURER	JUNE 2023	COLLECTED FUNDS-PIMA	07/13/2023	466.13	466.13	07/19/2023
10-20320 JCEF PAYABLE	1960	ARIZONA STATE TREASURER	JUNE 2023	COLLECTED FUNDS-SAFFORD	07/13/2023	9,697.35	9,697.35	07/19/2023
10-20320 JCEF PAYABLE	1960	ARIZONA STATE TREASURER	JUNE 2023	COLLECTED FUNDS-THATCHE	07/13/2023	4,249.06	4,249.06	07/19/2023
10-20320 JCEF PAYABLE	4302	CITY OF SAFFORD	JUNE 2023	MONTHLY COURT REVENUE	07/13/2023	4,124.98	4,124.98	07/19/2023
10-20320 JCEF PAYABLE	3482	DAVID EDWARDS	TR2022000051	RESTITUTION	07/17/2023	50.00	50.00	07/19/2023
10-20320 JCEF PAYABLE	10215	FRANCISCO ABEL OCHOA	CR2018271	TIPS REFUND	07/19/2023	566.00	566.00	07/26/2023
10-20320 JCEF PAYABLE	4505	GRAHAM COUNTY TREASURE	JUNE 2023	Z052 ADDITIONAL ASSESSMEN	07/13/2023	17.06	17.06	07/19/2023
10-20320 JCEF PAYABLE	10215	KIMBERLY KIDD	TR2022000197	RESTITUTION	06/29/2023	400.00	400.00	07/06/2023
10-20320 JCEF PAYABLE	10060	RICHARD PINO	CM202200035	BOND REFUND	07/19/2023	400.00	400.00	07/26/2023
10-20320 JCEF PAYABLE	10039	ROBIN MCDONALD	CM202200010	RESTITUTION	07/06/2023	225.19	225.19	07/13/2023
10-20320 JCEF PAYABLE	7379	SPEEDWAY	CM202200018	RESTITUTION	07/06/2023	28.00	28.00	07/13/2023
10-20320 JCEF PAYABLE	7390	ST ROSE OF LIMA	TR2022000140	RESTITUTION-T.S.ROBERTS	07/05/2023	25.00	25.00	07/13/2023
10-20320 JCEF PAYABLE	10215	STEVEN BOSWELL	CM201900010	BOND REFUND	07/19/2023	500.00	500.00	07/26/2023
10-20320 JCEF PAYABLE	7775	TOWN OF PIMA	JUNE 2023	MONTHLY COURT REVENUE	07/13/2023	303.87	303.87	07/19/2023
10-20320 JCEF PAYABLE	8245	WALMART COMMUNITY	CM202200017	RESTITUTION	07/24/2023	3.00	3.00	07/26/2023
10-20320 JCEF PAYABLE	8245	WALMART COMMUNITY	CM202300009	RESTITUTION	06/27/2023	50.00	50.00	07/13/2023
10-20320 JCEF PAYABLE	8245	WALMART COMMUNITY	CM202300009	RESTITUTION	07/24/2023	25.00	25.00	07/26/2023
10-20320 JCEF PAYABLE	8245	WALMART COMMUNITY	CM202300016	RESTITUTION	07/18/2023	29.96	29.96	07/26/2023
10-20320 JCEF PAYABLE	8245	WALMART COMMUNITY	CR2014205/07	RESTITUTION	07/19/2023	193.00	193.00	07/26/2023
Total 10-20320 JCEF PAYABLE:						21,378.60	21,378.60	
10-50-250 EMPLOYEE BONUS								
10-50-250 EMPLOYEE BONUS	2469	BMO HARRIS MASTERCARD	07236101	SAFEWAY - BDAY CARDS	07/05/2023	80.00	80.00	07/26/2023
10-50-250 EMPLOYEE BONUS	2469	BMO HARRIS MASTERCARD	07236101	LA CASITA - BDAY CARDS	07/05/2023	40.00	40.00	07/26/2023
Total 10-50-250 EMPLOYEE BONUS:						120.00	120.00	

GL Account and Title	Vendor	Vendor Name	Invoice Number	Description	Invoice Date	Net Invoice Amount	Amount Paid	Date Paid
10-50-310 TELEPHONE								
10-50-310 TELEPHONE	8130	VALLEY TELECOM	33664002/0701	TELEPHONE	07/01/2023	111.15	111.15	07/13/2023
Total 10-50-310 TELEPHONE:						111.15	111.15	
10-50-311 CELL PHONES & AIR CARDS								
10-50-311 CELL PHONES & AIR CARD	7827	TRANSWORLD NETWORK COR	15589095-A6	INTERNET	07/16/2023	21.24	21.24	07/26/2023
10-50-311 CELL PHONES & AIR CARD	8195	VERIZON WIRELESS	9938209028	AIR CARDS/CELL	06/26/2023	415.10	415.10	07/13/2023
Total 10-50-311 CELL PHONES & AIR CARDS:						436.34	436.34	
10-50-326 ATTORNEY								
10-50-326 ATTORNEY	5667	MATT N. CLIFFORD, P.C.	JULY 2023	ADMIN	07/05/2023	2,379.22	2,379.22	07/06/2023
Total 10-50-326 ATTORNEY:						2,379.22	2,379.22	
10-50-328 AUDITOR								
10-50-328 AUDITOR	2320	CHASE CARD SERVICES	JUNE 2023	COLUMN PBC	05/30/2023	242.62	242.62	07/19/2023
Total 10-50-328 AUDITOR:						242.62	242.62	
10-50-344 PRINTING & ADVERTISING								
10-50-344 PRINTING & ADVERTISING	5080	DOUBLE-R COMMUNICATIONS	78-00002-0009	PRINTING & ADVERTISING	06/30/2023	127.50	127.50	07/13/2023
10-50-344 PRINTING & ADVERTISING	5080	DOUBLE-R COMMUNICATIONS	78-00009-0000	PRINTING & ADVERTISING	06/30/2023	29.70	29.70	07/13/2023
Total 10-50-344 PRINTING & ADVERTISING:						157.20	157.20	
10-50-400 E-MAIL/WEBPAGE								
10-50-400 E-MAIL/WEBPAGE	2469	BMO HARRIS MASTERCARD	07235713	APP RIVER	07/05/2023	674.01	674.01	07/26/2023
Total 10-50-400 E-MAIL/WEBPAGE:						674.01	674.01	
10-50-430 CHAMBER								
10-50-430 CHAMBER	2995	CHAMBER OF COMMERCE	2963	THATCHER COMMUNITY PART	07/03/2023	12,000.00	12,000.00	07/13/2023
Total 10-50-430 CHAMBER:						12,000.00	12,000.00	
10-50-505 TRAINING/MEETING/TRAVEL								
10-50-505 TRAINING/MEETING/TRAVE	2469	BMO HARRIS MASTERCARD	07236101	GFOAZ CONF	07/05/2023	185.00	185.00	07/26/2023

GL Account and Title	Vendor	Vendor Name	Invoice Number	Description	Invoice Date	Net Invoice Amount	Amount Paid	Date Paid
Total 10-50-505 TRAINING/MEETING/TRAVEL:						185.00	185.00	
10-50-511 LEAGUE OF CITIES/TOWNS								
10-50-511 LEAGUE OF CITIES/TOWNS	2320	CHASE CARD SERVICES	JUNE 2023	LEAGUE CONFERENCE	05/30/2023	4,915.00	4,915.00	07/19/2023
Total 10-50-511 LEAGUE OF CITIES/TOWNS:						4,915.00	4,915.00	
10-50-512 SEAGO								
10-50-512 SEAGO	7075	SEAGO	2023-24	ANNUAL DUES & RTAC MEMBE	07/01/2023	2,742.00	2,742.00	07/13/2023
Total 10-50-512 SEAGO:						2,742.00	2,742.00	
10-50-590 MISCELLANEOUS								
10-50-590 MISCELLANEOUS	38	AARON ALLEN	2	4TH OF JULY DJ	07/12/2023	400.00	400.00	07/19/2023
10-50-590 MISCELLANEOUS	2469	BMO HARRIS MASTERCARD	07236101	WALMART - NAPKINS	07/05/2023	7.40	7.40	07/26/2023
10-50-590 MISCELLANEOUS	2469	BMO HARRIS MASTERCARD	07236101	AMCA FUND	07/05/2023	70.97	70.97	07/26/2023
Total 10-50-590 MISCELLANEOUS:						478.37	478.37	
10-50-750 DONATIONS								
10-50-750 DONATIONS	2469	BMO HARRIS MASTERCARD	07236101	SAFEWAY-AMCA DONATION	07/05/2023	105.95	105.95	07/26/2023
10-50-750 DONATIONS	7660	THATCHER UNIFIED SCH DIST.	2023-24	THS CHOIR-GREEN PACKAGE	07/24/2023	500.00	500.00	07/26/2023
Total 10-50-750 DONATIONS:						605.95	605.95	
10-52-305 INSURANCE DEDUCTIBLES								
10-52-305 INSURANCE DEDUCTIBLES	4143	FERRIN'S AUTO COLLISION CE	6137	SANDOVAL CAR REPAIR	07/11/2023	1,354.17	1,354.17	07/13/2023
10-52-305 INSURANCE DEDUCTIBLES	10215	GERARDO SANDOVAL	071123	CAR RENTAL	07/11/2023	205.35	205.35	07/13/2023
Total 10-52-305 INSURANCE DEDUCTIBLES:						1,559.52	1,559.52	
10-52-310 TELEPHONE								
10-52-310 TELEPHONE	8130	VALLEY TELECOM	33664002/0701	TELEPHONE	07/01/2023	772.12	772.12	07/13/2023
Total 10-52-310 TELEPHONE:						772.12	772.12	
10-52-311 CELL PHONES & AIR CARDS								
10-52-311 CELL PHONES & AIR CARD	7827	TRANSWORLD NETWORK COR	15589095-A6	INTERNET	07/16/2023	5.26	5.26	07/26/2023
10-52-311 CELL PHONES & AIR CARD	8195	VERIZON WIRELESS	9938209028	AIR CARDS/CELL	06/26/2023	102.89	102.89	07/13/2023

GL Account and Title	Vendor	Vendor Name	Invoice Number	Description	Invoice Date	Net Invoice Amount	Amount Paid	Date Paid
Total 10-52-311 CELL PHONES & AIR CARDS:						108.15	108.15	
10-52-312 WATER								
10-52-312 WATER	4302	CITY OF SAFFORD	16.161.01/0630	TOWN HALL	06/30/2023	688.78	688.78	07/13/2023
10-52-312 WATER	4302	CITY OF SAFFORD	17.529.02/0630	3670 W MAIN	06/30/2023	38.27	38.27	07/13/2023
Total 10-52-312 WATER:						727.05	727.05	
10-52-314 NATURAL GAS								
10-52-314 NATURAL GAS	7319	SOUTHWEST GAS	910003247045/	GAS	07/13/2023	77.00	77.00	07/19/2023
10-52-314 NATURAL GAS	7319	SOUTHWEST GAS	910003247046/	GAS	07/13/2023	48.48	48.48	07/19/2023
Total 10-52-314 NATURAL GAS:						125.48	125.48	
10-52-325 PROFESSIONAL TECHNICAL SERVICE								
10-52-325 PROFESSIONAL TECHNICA	4867	J C G TECHNOLOGIES	9036	MEETING RECORDER KIT	06/01/2023	450.00	450.00	07/13/2023
Total 10-52-325 PROFESSIONAL TECHNICAL SERVICE:						450.00	450.00	
10-52-340 OFFICE EQUIPMENT MAINTENANCE								
10-52-340 OFFICE EQUIPMENT MAIN	8272	WELLS FARGO FINANCE LEASI	5025742314	KYOCERA LEASE	06/30/2023	210.43	210.43	07/13/2023
Total 10-52-340 OFFICE EQUIPMENT MAINTENANCE:						210.43	210.43	
10-52-342 BUILDING MAINTENANCE								
10-52-342 BUILDING MAINTENANCE	4645	HOME DEPOT CREDIT SERVIC	3615343	COOL WHITE PACK	06/28/2023	103.62	103.62	07/19/2023
Total 10-52-342 BUILDING MAINTENANCE:						103.62	103.62	
10-52-344 PRINTING/ADVERTISING								
10-52-344 PRINTING/ADVERTISING	5080	DOUBLE-R COMMUNICATIONS	78-00002-0009	PRINTING & ADVERTISING	06/30/2023	85.00	85.00	07/13/2023
10-52-344 PRINTING/ADVERTISING	5080	DOUBLE-R COMMUNICATIONS	78-00009-0000	PRINTING & ADVERTISING	06/30/2023	19.80	19.80	07/13/2023
10-52-344 PRINTING/ADVERTISING	4491	GILA VALLEY CENTRAL	2480	SPORTS AD	07/01/2023	125.00	125.00	07/13/2023
Total 10-52-344 PRINTING/ADVERTISING:						229.80	229.80	
10-52-347 COMPUTER SOFTWARE SUPPORT								
10-52-347 COMPUTER SOFTWARE S	2905	CASELLE, INC.	125728	SOFTWARE SUPPORT	07/01/2023	812.00	812.00	07/06/2023

GL Account and Title	Vendor	Vendor Name	Invoice Number	Description	Invoice Date	Net Invoice Amount	Amount Paid	Date Paid
Total 10-52-347 COMPUTER SOFTWARE SUPPORT:						812.00	812.00	
10-52-505 TRAINING/MEETING/TRAVEL								
10-52-505 TRAINING/MEETING/TRAVE	704	ANNIE REIDHEAD	071923	AMCA ANNUAL CONF	07/19/2023	166.00	166.00	07/19/2023
10-52-505 TRAINING/MEETING/TRAVE	2469	BMO HARRIS MASTERCARD	07235333	LA CASITA - MANAGERS MEETI	07/05/2023	33.71	33.71	07/26/2023
10-52-505 TRAINING/MEETING/TRAVE	776	BROOKLYN ANGLE	071923	AMCA CONFERENCE	07/19/2023	270.00	270.00	07/19/2023
10-52-505 TRAINING/MEETING/TRAVE	81	HEATH BROWN	071123	ACMA CONFERENCE	07/11/2023	177.00	177.00	07/13/2023
10-52-505 TRAINING/MEETING/TRAVE	6250	PETTY CASH	071923	ACMA	07/19/2023	153.00	153.00	07/26/2023
Total 10-52-505 TRAINING/MEETING/TRAVEL:						799.71	799.71	
10-52-510 DUES/SUBSCRIPTIONS								
10-52-510 DUES/SUBSCRIPTIONS	2469	BMO HARRIS MASTERCARD	07236101	AMCA	07/05/2023	185.00	185.00	07/26/2023
10-52-510 DUES/SUBSCRIPTIONS	2320	CHASE CARD SERVICES	JUNE 2023	AMCA	05/30/2023	30.00	30.00	07/19/2023
Total 10-52-510 DUES/SUBSCRIPTIONS:						215.00	215.00	
10-52-528 HOLIDAY DECORATIONS								
10-52-528 HOLIDAY DECORATIONS	5865	MOSCA DESIGN	36752-2	SLEIGH & BOXES	07/01/2023	9,971.20	9,971.20	07/13/2023
Total 10-52-528 HOLIDAY DECORATIONS:						9,971.20	9,971.20	
10-52-535 POSTAGE								
10-52-535 POSTAGE	6355	PITNEY BOWES	060123	POSTAGE	06/01/2023	300.00	300.00	07/06/2023
Total 10-52-535 POSTAGE:						300.00	300.00	
10-52-540 OFFICE SUPPLIES								
10-52-540 OFFICE SUPPLIES	1467	AMAZON CAPITAL SERVICES, I	1GWC-D1K4-K	OFFICE SUPPLIES	07/01/2023	1,201.07	1,201.07	07/06/2023
10-52-540 OFFICE SUPPLIES	2469	BMO HARRIS MASTERCARD	07233385	WALMART - THANK YOU CARD	07/05/2023	7.62	7.62	07/26/2023
10-52-540 OFFICE SUPPLIES	2469	BMO HARRIS MASTERCARD	07233385	WALMART - SUPPLIES	07/05/2023	92.74	92.74	07/26/2023
10-52-540 OFFICE SUPPLIES	2469	BMO HARRIS MASTERCARD	07233385	WALMART - PAPER TOWELS	07/05/2023	39.21	39.21	07/26/2023
10-52-540 OFFICE SUPPLIES	2469	BMO HARRIS MASTERCARD	07233385	WALMART - SUPPLIES	07/05/2023	160.50	160.50	07/26/2023
10-52-540 OFFICE SUPPLIES	2469	BMO HARRIS MASTERCARD	07233385	WALMART - SUPPLIES	07/05/2023	90.36	90.36	07/26/2023
10-52-540 OFFICE SUPPLIES	2469	BMO HARRIS MASTERCARD	07233385	WALMART - SUPPLIES	07/05/2023	15.21	15.21	07/26/2023
10-52-540 OFFICE SUPPLIES	8235	WATER DEPOT	7448	REFILL	07/18/2023	18.00	18.00	07/26/2023
Total 10-52-540 OFFICE SUPPLIES:						1,624.71	1,624.71	

GL Account and Title	Vendor	Vendor Name	Invoice Number	Description	Invoice Date	Net Invoice Amount	Amount Paid	Date Paid
10-52-590 MISCELLANEOUS								
10-52-590 MISCELLANEOUS	1467	AMAZON CAPITAL SERVICES, I	1GWC-D1K4-K	MOVIE NIGHT	07/01/2023	146.87	146.87	07/06/2023
10-52-590 MISCELLANEOUS	2469	BMO HARRIS MASTERCARD	07233385	USPS	07/05/2023	9.85	9.85	07/26/2023
10-52-590 MISCELLANEOUS	2469	BMO HARRIS MASTERCARD	07235622	WALMART - 4TH OF JULY	07/05/2023	30.46	30.46	07/26/2023
10-52-590 MISCELLANEOUS	2469	BMO HARRIS MASTERCARD	07236259	BRANDING IRON - FUNDRAISE	07/05/2023	834.95	834.95	07/26/2023
10-52-590 MISCELLANEOUS	2469	BMO HARRIS MASTERCARD	07239614	BASHAS - SUPPLIES	07/05/2023	32.29	32.29	07/26/2023
10-52-590 MISCELLANEOUS	2469	BMO HARRIS MASTERCARD	07239614	SAFEWAY - 4TH OF JULY	07/05/2023	50.65	50.65	07/26/2023
10-52-590 MISCELLANEOUS	2469	BMO HARRIS MASTERCARD	07239614	WALMART - 4TH OF JULY	07/05/2023	86.19	86.19	07/26/2023
10-52-590 MISCELLANEOUS	2469	BMO HARRIS MASTERCARD	7235580	WALMART - 4TH OF JULY	07/05/2023	63.18	63.18	07/26/2023
10-52-590 MISCELLANEOUS	6250	PETTY CASH	071923	BASHAS- OPEN ENROLLEMEN	07/19/2023	18.43	18.43	07/26/2023
Total 10-52-590 MISCELLANEOUS:						1,272.87	1,272.87	
10-52-747 COMPUTER SOFTWARE								
10-52-747 COMPUTER SOFTWARE	2320	CHASE CARD SERVICES	JUNE 2023	ADOBE	05/30/2023	21.81	21.81	07/19/2023
Total 10-52-747 COMPUTER SOFTWARE:						21.81	21.81	
10-52-748 COMPUTER SUPPORT								
10-52-748 COMPUTER SUPPORT	3435	DAN MARTIN	JULY 2023	IT CONSULTING	07/03/2023	558.00	558.00	07/06/2023
Total 10-52-748 COMPUTER SUPPORT:						558.00	558.00	
10-52-750 VEHICLES								
10-52-750 VEHICLES	4042	ENTERPRISE FLEET MANAGEM	FBN4788216	TOWN HALL	07/06/2023	399.14	399.14	07/19/2023
Total 10-52-750 VEHICLES:						399.14	399.14	
10-55-312 WATER								
10-55-312 WATER	4302	CITY OF SAFFORD	73.045.09/0630	702 8TH AVE	06/30/2023	737.50	737.50	07/13/2023
Total 10-55-312 WATER:						737.50	737.50	
10-55-505 TRAINING/MEETING/TRAVEL								
10-55-505 TRAINING/MEETING/TRAVE	2469	BMO HARRIS MASTERCARD	07232112	GREEN TREE HOTEL - TRAININ	07/05/2023	480.12	480.12	07/26/2023
10-55-505 TRAINING/MEETING/TRAVE	2469	BMO HARRIS MASTERCARD	07235689	JW MARRIOTT - TRAINING	07/05/2023	382.25	382.25	07/26/2023
Total 10-55-505 TRAINING/MEETING/TRAVEL:						862.37	862.37	
10-55-510 DUES/SUBSCRIPTIONS								
10-55-510 DUES/SUBSCRIPTIONS	5248	LJCAA	2023	MEMBERSHIP	07/01/2023	25.00	25.00	07/13/2023

GL Account and Title	Vendor	Vendor Name	Invoice Number	Description	Invoice Date	Net Invoice Amount	Amount Paid	Date Paid
Total 10-55-510 DUES/SUBSCRIPTIONS:						25.00	25.00	
10-55-535 POSTAGE								
10-55-535 POSTAGE	6355	PITNEY BOWES	060123	POSTAGE	06/01/2023	45.00	45.00	07/06/2023
Total 10-55-535 POSTAGE:						45.00	45.00	
10-55-540 OFFICE SUPPLIES								
10-55-540 OFFICE SUPPLIES	2469	BMO HARRIS MASTERCARD	07239996	AMAZON - CUPS	07/05/2023	32.84	32.84	07/26/2023
10-55-540 OFFICE SUPPLIES	2469	BMO HARRIS MASTERCARD	07239996	AMAZON - CUPS	07/05/2023	24.90	24.90	07/26/2023
10-55-540 OFFICE SUPPLIES	2469	BMO HARRIS MASTERCARD	07239996	WALMART - SUPPLIES	07/05/2023	91.19	91.19	07/26/2023
10-55-540 OFFICE SUPPLIES	6520	QUILL CORPORATION	33095713	COURT SUPPLIES	06/20/2023	38.07	38.07	07/13/2023
10-55-540 OFFICE SUPPLIES	6520	QUILL CORPORATION	33114149	COURT SUPPLIES	06/20/2023	151.44	151.44	07/13/2023
10-55-540 OFFICE SUPPLIES	6520	QUILL CORPORATION	33137631	COURT SUPPLIES	06/21/2023	187.96	187.96	07/13/2023
10-55-540 OFFICE SUPPLIES	7365	SPARKLETTS	17051740 0708	WATER	07/08/2023	117.37	117.37	07/19/2023
Total 10-55-540 OFFICE SUPPLIES:						643.77	643.77	
10-62-150 ASP LABOR								
10-62-150 ASP LABOR	1930	ARIZONA STATE PRISON - SAF	S01527723062	LABOR	06/29/2023	73.07	73.07	07/06/2023
10-62-150 ASP LABOR	1930	ARIZONA STATE PRISON - SAF	S01530423070	LABOR	07/14/2023	92.07	92.07	07/19/2023
10-62-150 ASP LABOR	1930	ARIZONA STATE PRISON - SAF	TOT23-26	LABOR	07/14/2023	18.28	18.28	07/19/2023
Total 10-62-150 ASP LABOR:						183.42	183.42	
10-62-311 CELL PHONES & AIR CARDS								
10-62-311 CELL PHONES & AIR CARD	2469	BMO HARRIS MASTERCARD	07235713	BLUESPAN	07/05/2023	78.98	78.98	07/26/2023
10-62-311 CELL PHONES & AIR CARD	2832	SPARKLIGHT	121419568/070	INTERNET	07/08/2023	94.69	94.69	07/19/2023
10-62-311 CELL PHONES & AIR CARD	7827	TRANSWORLD NETWORK COR	15589095-A6	INTERNET	07/16/2023	3.99	3.99	07/26/2023
10-62-311 CELL PHONES & AIR CARD	8195	VERIZON WIRELESS	9938209028	AIR CARDS/CELL	06/26/2023	78.05	78.05	07/13/2023
Total 10-62-311 CELL PHONES & AIR CARDS:						255.71	255.71	
10-62-312 WATER								
10-62-312 WATER	4302	CITY OF SAFFORD	12.702.00/0630	REAY LN & DALEY FOUNTAIN	06/30/2023	32.78	32.78	07/13/2023
10-62-312 WATER	4302	CITY OF SAFFORD	13.425.01/0630	DALEY PARK	06/30/2023	640.01	640.01	07/13/2023
10-62-312 WATER	4302	CITY OF SAFFORD	14.950.01/0630	IRRIGATION	06/30/2023	616.96	616.96	07/13/2023
10-62-312 WATER	4302	CITY OF SAFFORD	15.218.00/0630	HIGHLINE & REAY FOUNTAIN	06/30/2023	32.78	32.78	07/13/2023
10-62-312 WATER	4302	CITY OF SAFFORD	15.268.01/0630	SPLASHPARK/CEMETERY	06/30/2023	825.43	825.43	07/13/2023
10-62-312 WATER	4302	CITY OF SAFFORD	15.785.01/0630	2161 HWY 70	06/30/2023	136.64	136.64	07/13/2023

GL Account and Title	Vendor	Vendor Name	Invoice Number	Description	Invoice Date	Net Invoice Amount	Amount Paid	Date Paid
10-62-312 WATER	4302	CITY OF SAFFORD	15.970.00/0630	EAGLE MEADOW	06/30/2023	154.47	154.47	07/13/2023
10-62-312 WATER	4302	CITY OF SAFFORD	16.385.01/0630	REAY LANE PARK	06/30/2023	33.61	33.61	07/13/2023
10-62-312 WATER	4302	CITY OF SAFFORD	17.830.01/0630	LANDSCAPE METER	06/30/2023	428.85	428.85	07/13/2023
10-62-312 WATER	4302	CITY OF SAFFORD	81.674.02/0630	8th ST LANDSCAPE	06/30/2023	117.03	117.03	07/13/2023
10-62-312 WATER	4302	CITY OF SAFFORD	81.675.02/0630	8th ST LANDSCAPE	06/30/2023	32.78	32.78	07/13/2023
Total 10-62-312 WATER:						3,051.34	3,051.34	
10-62-317 SWIM LEAGUE								
10-62-317 SWIM LEAGUE	9042	ANERON PALMER	2023	SWIM TEAM	07/12/2023	1,800.00	1,800.00	07/13/2023
10-62-317 SWIM LEAGUE	10215	ASHLYN OLIVER	2023	SWIM TEAM	07/12/2023	1,128.76	1,128.76	07/13/2023
10-62-317 SWIM LEAGUE	2972	CMI QUICK COPY	47950	SWIM TEAM COPIES	05/25/2023	156.29	156.29	07/13/2023
10-62-317 SWIM LEAGUE	10157	ELIZA BARRON	2023	SWIM TEAM	07/12/2023	1,274.20	1,274.20	07/13/2023
10-62-317 SWIM LEAGUE	10202	JADE GRIFFIN	2023	SWIM TEAM	07/12/2023	1,184.18	1,184.18	07/13/2023
10-62-317 SWIM LEAGUE	10187	LEILIA OLIVER	2023	SWIM TEAM	07/12/2023	1,121.85	1,121.85	07/13/2023
10-62-317 SWIM LEAGUE	10081	MADISON WEBB	2023	SWIM TEAM	07/12/2023	1,800.00	1,800.00	07/13/2023
10-62-317 SWIM LEAGUE	10187	MAGGIE BARRON	2023	SWIM TEAM	07/12/2023	1,274.20	1,274.20	07/13/2023
Total 10-62-317 SWIM LEAGUE:						9,739.48	9,739.48	
10-62-323 SUMMER BASEBALL								
10-62-323 SUMMER BASEBALL	9104	MICHAEL RICHINS	06/12-06/21	SUMMER BASEBALL	07/19/2023	200.00	200.00	07/19/2023
Total 10-62-323 SUMMER BASEBALL:						200.00	200.00	
10-62-325 PROFESSIONAL/TECHNICAL SERVICE								
10-62-325 PROFESSIONAL/TECHNICA	5447	LOGANSIMPSON	32334	THATCHER BALLPARK CD'S	07/24/2023	3,086.86	3,086.86	07/26/2023
Total 10-62-325 PROFESSIONAL/TECHNICAL SERVICE:						3,086.86	3,086.86	
10-62-523 BASEBALL SUPPLIES								
10-62-523 BASEBALL SUPPLIES	2469	BMO HARRIS MASTERCARD	07235622	HOME DEPOT - MAXCOOL	07/05/2023	68.23	68.23	07/26/2023
10-62-523 BASEBALL SUPPLIES	2469	BMO HARRIS MASTERCARD	07236259	CROWN AWARDS	07/05/2023	1,644.29	1,644.29	07/26/2023
10-62-523 BASEBALL SUPPLIES	2469	BMO HARRIS MASTERCARD	07236259	AMAZON - BASEBALL SUPPLIE	07/05/2023	80.33	80.33	07/26/2023
10-62-523 BASEBALL SUPPLIES	6880	SAFFORD BUILDERS SUPPLY C	154287	STARTER PAWL	06/01/2023	50.75	50.75	07/06/2023
10-62-523 BASEBALL SUPPLIES	6880	SAFFORD BUILDERS SUPPLY C	971605	FIELD MARKER	06/12/2023	870.07	870.07	07/06/2023
Total 10-62-523 BASEBALL SUPPLIES:						2,713.67	2,713.67	
10-62-533 SMALL TOOLS/HARDWARE								
10-62-533 SMALL TOOLS/HARDWARE	2469	BMO HARRIS MASTERCARD	07235622	HOME DEPOT - SPECTRACIDE	07/05/2023	116.45	116.45	07/26/2023

GL Account and Title	Vendor	Vendor Name	Invoice Number	Description	Invoice Date	Net Invoice Amount	Amount Paid	Date Paid
Total 10-62-533 SMALL TOOLS/HARDWARE:						116.45	116.45	
10-62-540 SPLASH PAD MAINTENANCE								
10-62-540 SPLASH PAD MAINTENANC	2469	BMO HARRIS MASTERCARD	07235614	HOME DEPOT - SPLASH PAD P	07/05/2023	74.90	74.90	07/26/2023
10-62-540 SPLASH PAD MAINTENANC	2469	BMO HARRIS MASTERCARD	07235622	LEE TOOLS	07/05/2023	182.14	182.14	07/26/2023
Total 10-62-540 SPLASH PAD MAINTENANCE:						257.04	257.04	
10-62-541 EQUIPMENT SUPPLIES								
10-62-541 EQUIPMENT SUPPLIES	2469	BMO HARRIS MASTERCARD	07235622	HOME DEPOT - ROPE	07/05/2023	117.57	117.57	07/26/2023
10-62-541 EQUIPMENT SUPPLIES	2469	BMO HARRIS MASTERCARD	07235622	HOME DEPOT - GOGGLES	07/05/2023	22.85	22.85	07/26/2023
Total 10-62-541 EQUIPMENT SUPPLIES:						140.42	140.42	
10-62-542 BLDG MATERIALS/SUPPLIES								
10-62-542 BLDG MATERIALS/SUPPLIE	2469	BMO HARRIS MASTERCARD	07235614	HOME DEPOT - TOILET SEAL	07/05/2023	57.75	57.75	07/26/2023
10-62-542 BLDG MATERIALS/SUPPLIE	2469	BMO HARRIS MASTERCARD	07235622	TRACTOR SUPPLY - NO SPILL	07/05/2023	106.85	106.85	07/26/2023
10-62-542 BLDG MATERIALS/SUPPLIE	2469	BMO HARRIS MASTERCARD	07235622	AMAZON - COOLER	07/05/2023	33.30	33.30	07/26/2023
10-62-542 BLDG MATERIALS/SUPPLIE	2469	BMO HARRIS MASTERCARD	07235739	CMI-SIGNAGE	07/05/2023	94.37	94.37	07/26/2023
10-62-542 BLDG MATERIALS/SUPPLIE	2469	BMO HARRIS MASTERCARD	07235739	ACTUATOR	07/05/2023	129.35	129.35	07/26/2023
10-62-542 BLDG MATERIALS/SUPPLIE	2469	BMO HARRIS MASTERCARD	07235739	WEBSTAUARANT STORE	07/05/2023	298.01	298.01	07/26/2023
10-62-542 BLDG MATERIALS/SUPPLIE	6880	SAFFORD BUILDERS SUPPLY C	971919	WATER COOLER	06/14/2023	43.52	43.52	07/06/2023
10-62-542 BLDG MATERIALS/SUPPLIE	6880	SAFFORD BUILDERS SUPPLY C	972575	CONNECTERS	06/21/2023	22.54	22.54	07/06/2023
Total 10-62-542 BLDG MATERIALS/SUPPLIES:						785.69	785.69	
10-62-553 TIRES & BATTERIES								
10-62-553 TIRES & BATTERIES	2545	BIG O TIRES	004224-10656	TIRES	06/27/2023	285.99	285.99	07/19/2023
Total 10-62-553 TIRES & BATTERIES:						285.99	285.99	
10-62-555 GAS/OIL/LUBRICANTS								
10-62-555 GAS/OIL/LUBRICANTS	7945	SENERGY PETROLEUM	SEN-581667	GAS/DIESEL	07/12/2023	879.72	879.72	07/19/2023
Total 10-62-555 GAS/OIL/LUBRICANTS:						879.72	879.72	
10-62-590 MISCELLANEOUS								
10-62-590 MISCELLANEOUS	2469	BMO HARRIS MASTERCARD	07235622	HOME DEPOT - STARTERKIT	07/05/2023	521.50	521.50	07/26/2023

GL Account and Title	Vendor	Vendor Name	Invoice Number	Description	Invoice Date	Net Invoice Amount	Amount Paid	Date Paid
Total 10-62-590 MISCELLANEOUS:						521.50	521.50	
10-62-650 CEMETERY								
10-62-650 CEMETERY	4125	FERTIZONA - THATCHER, LLC	19041749	HONCHO K6	06/28/2023	4,922.00	4,922.00	07/13/2023
Total 10-62-650 CEMETERY:						4,922.00	4,922.00	
10-62-750 VEHICLES								
10-62-750 VEHICLES	4042	ENTERPRISE FLEET MANAGEM	FBN4788216	PARKS - CLARIDGE	07/06/2023	716.07	716.07	07/19/2023
10-62-750 VEHICLES	4042	ENTERPRISE FLEET MANAGEM	FBN4788216	PARKS - WHITMIRE	07/06/2023	724.74	724.74	07/19/2023
Total 10-62-750 VEHICLES:						1,440.81	1,440.81	
10-70-310 TELEPHONE								
10-70-310 TELEPHONE	8130	VALLEY TELECOM	33664002/0701	TELEPHONE	07/01/2023	331.47	331.47	07/13/2023
Total 10-70-310 TELEPHONE:						331.47	331.47	
10-70-311 CELL PHONES & AIR CARDS								
10-70-311 CELL PHONES & AIR CARD	7827	TRANSWORLD NETWORK COR	15589095-A6	INTERNET	07/16/2023	31.76	31.76	07/26/2023
10-70-311 CELL PHONES & AIR CARD	8195	VERIZON WIRELESS	9938209028	AIR CARDS/CELL	06/26/2023	620.87	620.87	07/13/2023
Total 10-70-311 CELL PHONES & AIR CARDS:						652.63	652.63	
10-70-334 DISPATCHING								
10-70-334 DISPATCHING	4420	GRAHAM CO BOARD OF SUPE	2024-0002	DISPATCHING SERVICES	07/01/2023	65,911.59	65,911.59	07/06/2023
Total 10-70-334 DISPATCHING:						65,911.59	65,911.59	
10-70-335 BODY CAMERA CONTRACT								
10-70-335 BODY CAMERA CONTRACT	7545	AXON ENTERPRISES, INC	INUS168796	UNLIMITED7	07/01/2023	581.70	581.70	07/19/2023
10-70-335 BODY CAMERA CONTRACT	7545	AXON ENTERPRISES, INC	INUS169256	BWCAMTAP	07/01/2023	17,802.05	17,802.05	07/19/2023
Total 10-70-335 BODY CAMERA CONTRACT:						18,383.75	18,383.75	
10-70-344 PRINTING/ADVERTISING								
10-70-344 PRINTING/ADVERTISING	5080	DOUBLE-R COMMUNICATIONS	78-00002-0009	PRINTING & ADVERTISING	06/30/2023	140.25	140.25	07/13/2023
10-70-344 PRINTING/ADVERTISING	5080	DOUBLE-R COMMUNICATIONS	78-00009-0000	PRINTING & ADVERTISING	06/30/2023	32.67	32.67	07/13/2023

GL Account and Title	Vendor	Vendor Name	Invoice Number	Description	Invoice Date	Net Invoice Amount	Amount Paid	Date Paid
Total 10-70-344 PRINTING/ADVERTISING:						172.92	172.92	
10-70-350 VEHICLE MAINTENANCE								
10-70-350 VEHICLE MAINTENANCE	2320	CHASE CARD SERVICES	JUNE 2023	JJ EXPRESS WASH	05/30/2023	9.65	9.65	07/19/2023
10-70-350 VEHICLE MAINTENANCE	2320	CHASE CARD SERVICES	JUNE 2023	JJ EXPRESS WASH	05/30/2023	244.20	244.20	07/19/2023
10-70-350 VEHICLE MAINTENANCE	3075	FIRST CALL AUTO PARTS	2752-169441	TENSIONER	06/06/2023	67.88	67.88	07/26/2023
10-70-350 VEHICLE MAINTENANCE	3075	FIRST CALL AUTO PARTS	2752-171150	OIL FILTER	06/13/2023	40.40	40.40	07/26/2023
10-70-350 VEHICLE MAINTENANCE	3075	FIRST CALL AUTO PARTS	2752-171152	AIR FILTER	06/13/2023	38.88	38.88	07/26/2023
10-70-350 VEHICLE MAINTENANCE	5530	MACK'S AUTO SUPPLY	144942	CORE KIT	06/22/2023	15.15	15.15	07/19/2023
Total 10-70-350 VEHICLE MAINTENANCE:						416.16	416.16	
10-70-360 ANIMAL CONTROL SERVICES								
10-70-360 ANIMAL CONTROL SERVIC	4420	GRAHAM CO BOARD OF SUPE	2023-0093	ANIMAL CONTROL	06/30/2023	300.00	300.00	07/06/2023
10-70-360 ANIMAL CONTROL SERVIC	4420	GRAHAM CO BOARD OF SUPE	2024-0006	ANIMAL SHELTER	07/01/2023	9,033.66	9,033.66	07/06/2023
Total 10-70-360 ANIMAL CONTROL SERVICES:						9,333.66	9,333.66	
10-70-505 TRAINING/MEETING/TRAVEL								
10-70-505 TRAINING/MEETING/TRAVE	2469	BMO HARRIS MASTERCARD	07230190	BASHAS - ALICE TRAINING	07/05/2023	82.11	82.11	07/26/2023
10-70-505 TRAINING/MEETING/TRAVE	2469	BMO HARRIS MASTERCARD	07230190	BASHAS - ALICE TRAINING	07/05/2023	81.79	81.79	07/26/2023
10-70-505 TRAINING/MEETING/TRAVE	2469	BMO HARRIS MASTERCARD	07230190	BASHAS - ALICE TRAINING.	07/05/2023	9.21	9.21	07/26/2023
10-70-505 TRAINING/MEETING/TRAVE	2469	BMO HARRIS MASTERCARD	07234169	SAFEWAY - ALICE TRAINING	07/05/2023	65.46	65.46	07/26/2023
10-70-505 TRAINING/MEETING/TRAVE	2469	BMO HARRIS MASTERCARD	07234169	SAFEWAY - ALICE TRAINING	07/05/2023	65.46	65.46	07/26/2023
10-70-505 TRAINING/MEETING/TRAVE	2469	BMO HARRIS MASTERCARD	07235440	MT GRAHAM MRKT-GAS	07/05/2023	13.56	13.56	07/26/2023
10-70-505 TRAINING/MEETING/TRAVE	2469	BMO HARRIS MASTERCARD	07235515	SHELL - GAS	07/05/2023	83.28	83.28	07/26/2023
10-70-505 TRAINING/MEETING/TRAVE	2469	BMO HARRIS MASTERCARD	07235523	AZLERMA	07/05/2023	25.00	25.00	07/26/2023
10-70-505 TRAINING/MEETING/TRAVE	80	KRIS LEMON	070523	AZLERMA	07/05/2023	624.46	624.46	07/06/2023
10-70-505 TRAINING/MEETING/TRAVE	79	SHAFFEN WOODS	070523	FBI NCC	07/05/2023	208.00	208.00	07/06/2023
Total 10-70-505 TRAINING/MEETING/TRAVEL:						1,258.33	1,258.33	
10-70-510 DUES/SUBSCRIPTIONS								
10-70-510 DUES/SUBSCRIPTIONS	3895	EDWARDS & AMATO, P.C.	646	CONSULTATION/SUBSCRIPTIO	07/21/2023	1,700.00	1,700.00	07/26/2023
10-70-510 DUES/SUBSCRIPTIONS	6780	ROCKY MOUNTAIN INFO NETW	24598	DUES/SUBSCRIPTIONS	07/12/2023	50.00	50.00	07/19/2023
Total 10-70-510 DUES/SUBSCRIPTIONS:						1,750.00	1,750.00	
10-70-515 K9								
10-70-515 K9	2469	BMO HARRIS MASTERCARD	07235515	CHEWY.COM	07/05/2023	74.16	74.16	07/26/2023

GL Account and Title	Vendor	Vendor Name	Invoice Number	Description	Invoice Date	Net Invoice Amount	Amount Paid	Date Paid
Total 10-70-515 K9:						74.16	74.16	
10-70-535 POSTAGE								
10-70-535 POSTAGE	6355	PITNEY BOWES	060123	POSTAGE	06/01/2023	45.00	45.00	07/06/2023
Total 10-70-535 POSTAGE:						45.00	45.00	
10-70-540 OFFICE SUPPLIES								
10-70-540 OFFICE SUPPLIES	2469	BMO HARRIS MASTERCARD	07233385	LTRON - PAPER	07/05/2023	215.00	215.00	07/26/2023
10-70-540 OFFICE SUPPLIES	2469	BMO HARRIS MASTERCARD	07235499	BASHAS - SUPPLIES	07/05/2023	18.40	18.40	07/26/2023
10-70-540 OFFICE SUPPLIES	2469	BMO HARRIS MASTERCARD	7235424	S.CARTER PURCHASES	07/05/2023	1,926.73	1,926.73	07/26/2023
Total 10-70-540 OFFICE SUPPLIES:						2,160.13	2,160.13	
10-70-541 EQUIPMENT SUPPLIES								
10-70-541 EQUIPMENT SUPPLIES	6880	SAFFORD BUILDERS SUPPLY C	972561	LIGHTER	06/21/2023	8.28	8.28	07/06/2023
Total 10-70-541 EQUIPMENT SUPPLIES:						8.28	8.28	
10-70-555 GAS/OIL/LUBRICANTS								
10-70-555 GAS/OIL/LUBRICANTS	7945	SENERGY PETROLEUM	SEN-581667	GAS/DIESEL	07/12/2023	3,130.91	3,130.91	07/19/2023
Total 10-70-555 GAS/OIL/LUBRICANTS:						3,130.91	3,130.91	
10-70-590 MISCELLANEOUS								
10-70-590 MISCELLANEOUS	2469	BMO HARRIS MASTERCARD	07235499	THRIFTEE - CAKE	07/05/2023	34.83	34.83	07/26/2023
10-70-590 MISCELLANEOUS	2469	BMO HARRIS MASTERCARD	07235499	DOLLAR TREE - DECOR RETIR	07/05/2023	25.91	25.91	07/26/2023
10-70-590 MISCELLANEOUS	6250	PETTY CASH	071923	ADOT	07/19/2023	4.00	4.00	07/26/2023
Total 10-70-590 MISCELLANEOUS:						64.74	64.74	
10-70-748 COMPUTER SUPPORT								
10-70-748 COMPUTER SUPPORT	3435	DAN MARTIN	JULY 2023	IT CONSULTING	07/03/2023	558.00	558.00	07/06/2023
Total 10-70-748 COMPUTER SUPPORT:						558.00	558.00	
10-70-750 VEHICLES								
10-70-750 VEHICLES	4042	ENTERPRISE FLEET MANAGEM	FBN4788216	POLICE - MANER	07/06/2023	1,191.70	1,191.70	07/19/2023
10-70-750 VEHICLES	4042	ENTERPRISE FLEET MANAGEM	FBN4788216	POLICE - WEST	07/06/2023	338.91	338.91	07/19/2023
10-70-750 VEHICLES	4042	ENTERPRISE FLEET MANAGEM	FBN4788216	POLICE - THATCHER	07/06/2023	962.15	962.15	07/19/2023

GL Account and Title	Vendor	Vendor Name	Invoice Number	Description	Invoice Date	Net Invoice Amount	Amount Paid	Date Paid	
10-70-750 VEHICLES	4042	ENTERPRISE FLEET MANAGEM	FBN4788216	POLICE- LARSON	07/06/2023	1,121.00	1,121.00	07/19/2023	
10-70-750 VEHICLES	4042	ENTERPRISE FLEET MANAGEM	FBN4788216	POLICE - WHISMAN	07/06/2023	1,301.05	1,301.05	07/19/2023	
10-70-750 VEHICLES	4042	ENTERPRISE FLEET MANAGEM	FBN4788216	POLICE - ARBIZO	07/06/2023	1,198.15	1,198.15	07/19/2023	
Total 10-70-750 VEHICLES:						6,112.96	6,112.96		
10-72-310 TELEPHONE									
10-72-310 TELEPHONE	8130	VALLEY TELECOM	33664002/0701	TELEPHONE	07/01/2023	146.88	146.88	07/13/2023	
Total 10-72-310 TELEPHONE:						146.88	146.88		
10-72-312 WATER									
10-72-312 WATER	4302	CITY OF SAFFORD	17.528.01/0630	FIRE DEPARTMENT	06/30/2023	128.90	128.90	07/13/2023	
Total 10-72-312 WATER:						128.90	128.90		
10-72-320 FIRE FIGHTER CANCER FUND									
10-72-320 FIRE FIGHTER CANCER FU	4813	INDUSTRIAL COMMISSION OF	M23-00000629	FY 2024 MUNICIPAL FIREFIGHT	07/05/2023	13,836.02	13,836.02	07/06/2023	
Total 10-72-320 FIRE FIGHTER CANCER FUND:						13,836.02	13,836.02		
10-72-340 OFFICE EQUIPMENT MAINTENANCE									
10-72-340 OFFICE EQUIPMENT MAIN	4840	INTERSTATE ELECTRONICS IN	13634	COPIES	06/30/2023	96.63	96.63	07/13/2023	
Total 10-72-340 OFFICE EQUIPMENT MAINTENANCE:						96.63	96.63		
10-72-341 EQUIPMENT MAINTENANCE									
10-72-341 EQUIPMENT MAINTENANC	4687	HUGHES FIRE EQUIPMENT, INC	594478	DEF HEADER	06/14/2023	1,144.33	1,144.33	07/26/2023	
Total 10-72-341 EQUIPMENT MAINTENANCE:						1,144.33	1,144.33		
10-72-342 BUILDING MAINTENANCE									
10-72-342 BUILDING MAINTENANCE	4645	HOME DEPOT CREDIT SERVIC	5973290	VINYL FENCE	07/06/2023	1,180.36	1,180.36	07/19/2023	
Total 10-72-342 BUILDING MAINTENANCE:						1,180.36	1,180.36		
10-72-350 VEHICLE MAINTENANCE									
10-72-350 VEHICLE MAINTENANCE	2469	BMO HARRIS MASTERCARD	07237364	TRUCK PRO - FAN	07/05/2023	87.52	87.52	07/26/2023	
Total 10-72-350 VEHICLE MAINTENANCE:						87.52	87.52		

GL Account and Title	Vendor	Vendor Name	Invoice Number	Description	Invoice Date	Net Invoice Amount	Amount Paid	Date Paid
10-72-505 TRAINING/MEETING/TRAVEL								
10-72-505 TRAINING/MEETING/TRAVE	2469	BMO HARRIS MASTERCARD	07233942	HOME DEPOT - TIEDOWNS	07/05/2023	234.29	234.29	07/26/2023
10-72-505 TRAINING/MEETING/TRAVE	6190	SE BOTTLING CO OF AZ, INC	352617	SODAS	06/13/2023	1,403.41	1,403.41	07/06/2023
Total 10-72-505 TRAINING/MEETING/TRAVEL:						1,637.70	1,637.70	
10-72-533 SMALL TOOLS/HARDWARE								
10-72-533 SMALL TOOLS/HARDWARE	2469	BMO HARRIS MASTERCARD	07233942	HOME DEPOT - TOOLS	07/05/2023	535.92	535.92	07/26/2023
Total 10-72-533 SMALL TOOLS/HARDWARE:						535.92	535.92	
10-72-540 OFFICE SUPPLIES								
10-72-540 OFFICE SUPPLIES	2469	BMO HARRIS MASTERCARD	07233942	WALMART - INK	07/05/2023	109.93	109.93	07/26/2023
Total 10-72-540 OFFICE SUPPLIES:						109.93	109.93	
10-72-545 RADIO SUPPLIES								
10-72-545 RADIO SUPPLIES	2469	BMO HARRIS MASTERCARD	07233942	AMAZON - CHARGERS	07/05/2023	81.83	81.83	07/26/2023
Total 10-72-545 RADIO SUPPLIES:						81.83	81.83	
10-72-550 VEHICLE SUPPLIES								
10-72-550 VEHICLE SUPPLIES	5528	RV STRIPES & GRAPHICS, INC	28948	REPLACEMENT STRIPES/DORR	05/15/2023	274.86	274.86	07/13/2023
Total 10-72-550 VEHICLE SUPPLIES:						274.86	274.86	
10-72-555 GAS/OIL/LUBRICANTS								
10-72-555 GAS/OIL/LUBRICANTS	7945	SENERGY PETROLEUM	SEN-581667	GAS/DIESEL	07/12/2023	710.04	710.04	07/19/2023
Total 10-72-555 GAS/OIL/LUBRICANTS:						710.04	710.04	
10-72-740 OFFICE FURNITURE/EQUIP								
10-72-740 OFFICE FURNITURE/EQUIP	2469	BMO HARRIS MASTERCARD	07233942	AMAZON - CABINET	07/05/2023	725.50	725.50	07/26/2023
Total 10-72-740 OFFICE FURNITURE/EQUIP:						725.50	725.50	
10-72-741 MACHINERY/EQUIPMENT								
10-72-741 MACHINERY/EQUIPMENT	2469	BMO HARRIS MASTERCARD	07233942	HOME DEPOT - PREMIX	07/05/2023	686.24	686.24	07/26/2023
10-72-741 MACHINERY/EQUIPMENT	2469	BMO HARRIS MASTERCARD	07233942	VALLEY FURNITURE- SOFA	07/05/2023	3,367.23	3,367.23	07/26/2023
10-72-741 MACHINERY/EQUIPMENT	5250	L. N. CURTIS & SONS	PINV820548	IMAGER	06/30/2023	8,693.23	8,693.23	07/19/2023

GL Account and Title	Vendor	Vendor Name	Invoice Number	Description	Invoice Date	Net Invoice Amount	Amount Paid	Date Paid
Total 10-72-741 MACHINERY/EQUIPMENT:						12,746.70	12,746.70	
10-72-748 COMPUTER HARDWARE								
10-72-748 COMPUTER HARDWARE	3435	DAN MARTIN	JULY 2023	IT CONSULTING	07/03/2023	168.00	168.00	07/06/2023
Total 10-72-748 COMPUTER HARDWARE:						168.00	168.00	
10-72-750 VEHICLES								
10-72-750 VEHICLES	4042	ENTERPRISE FLEET MANAGEM	FBN4788216	FIRE DEPT	07/06/2023	1,220.69	1,220.69	07/19/2023
Total 10-72-750 VEHICLES:						1,220.69	1,220.69	
10-81-140 CLOTHING ALLOWANCE								
10-81-140 CLOTHING ALLOWANCE	8332	CINTAS PHOENIX FIRE PROTE	4157789520	CLOTHING	06/07/2023	446.59	446.59	07/19/2023
10-81-140 CLOTHING ALLOWANCE	8332	CINTAS PHOENIX FIRE PROTE	4158526693	CLOTHING	06/14/2023	365.23	365.23	07/19/2023
10-81-140 CLOTHING ALLOWANCE	8332	CINTAS PHOENIX FIRE PROTE	4159204261	CLOTHING	06/21/2023	367.93	367.93	07/19/2023
10-81-140 CLOTHING ALLOWANCE	8332	CINTAS PHOENIX FIRE PROTE	4159900250	CLOTHING	06/28/2023	361.75	361.75	07/19/2023
Total 10-81-140 CLOTHING ALLOWANCE:						1,541.50	1,541.50	
10-81-150 ASP LABOR								
10-81-150 ASP LABOR	1930	ARIZONA STATE PRISON - SAF	S01527723062	LABOR	06/29/2023	73.06	73.06	07/06/2023
10-81-150 ASP LABOR	1930	ARIZONA STATE PRISON - SAF	S01530423070	LABOR	07/14/2023	92.07	92.07	07/19/2023
10-81-150 ASP LABOR	1930	ARIZONA STATE PRISON - SAF	TOT23-26	LABOR	07/14/2023	18.28	18.28	07/19/2023
Total 10-81-150 ASP LABOR:						183.41	183.41	
10-81-310 TELEPHONE								
10-81-310 TELEPHONE	8130	VALLEY TELECOM	33664002/0701	TELEPHONE	07/01/2023	73.44	73.44	07/13/2023
Total 10-81-310 TELEPHONE:						73.44	73.44	
10-81-311 CELL PHONES & AIR CARDS								
10-81-311 CELL PHONES & AIR CARD	7827	TRANSWORLD NETWORK COR	15589095-A6	INTERNET	07/16/2023	4.63	4.63	07/26/2023
10-81-311 CELL PHONES & AIR CARD	8195	VERIZON WIRELESS	9938209028	AIR CARDS/CELL	06/26/2023	90.47	90.47	07/13/2023
Total 10-81-311 CELL PHONES & AIR CARDS:						95.10	95.10	
10-81-312 WATER								
10-81-312 WATER	4302	CITY OF SAFFORD	15.273.01/0630	SHOP	06/30/2023	282.60	282.60	07/13/2023

GL Account and Title	Vendor	Vendor Name	Invoice Number	Description	Invoice Date	Net Invoice Amount	Amount Paid	Date Paid
Total 10-81-312 WATER:						282.60	282.60	
10-81-350 VEHICLE MAINTENANCE								
10-81-350 VEHICLE MAINTENANCE	3075	FIRST CALL AUTO PARTS	2752-168194	BATT CLAMPS	06/01/2023	18.54	18.54	07/26/2023
10-81-350 VEHICLE MAINTENANCE	3075	FIRST CALL AUTO PARTS	2752-173458	PIGTAIL	06/22/2023	80.28	80.28	07/26/2023
10-81-350 VEHICLE MAINTENANCE	3075	FIRST CALL AUTO PARTS	2752-173564	RELAY	06/22/2023	31.90	31.90	07/26/2023
10-81-350 VEHICLE MAINTENANCE	3075	FIRST CALL AUTO PARTS	2752-174406	IGN LOCK	06/26/2023	42.20	42.20	07/26/2023
10-81-350 VEHICLE MAINTENANCE	3075	FIRST CALL AUTO PARTS	2752-174666	RADIATOR CAP	06/27/2023	12.64	12.64	07/26/2023
10-81-350 VEHICLE MAINTENANCE	3075	FIRST CALL AUTO PARTS	2752-174714	FUEL FILTER	06/27/2023	4.19	4.19	07/26/2023
10-81-350 VEHICLE MAINTENANCE	3075	FIRST CALL AUTO PARTS	2752-174728	FUEL FILTER	06/27/2023	4.34	4.34	07/26/2023
10-81-350 VEHICLE MAINTENANCE	3075	FIRST CALL AUTO PARTS	2752-174729	RELAY	06/27/2023	96.92-	96.92-	07/26/2023
10-81-350 VEHICLE MAINTENANCE	3075	FIRST CALL AUTO PARTS	2752-174811	CAP	06/27/2023	3.86-	3.86-	07/26/2023
Total 10-81-350 VEHICLE MAINTENANCE:						93.31	93.31	
10-81-533 SMALL TOOLS/HARDWARE								
10-81-533 SMALL TOOLS/HARDWARE	5363	LEE TOOLS LLC	3741	TOOLS	06/29/2023	545.33	545.33	07/19/2023
10-81-533 SMALL TOOLS/HARDWARE	5363	LEE TOOLS LLC	3811	TENSIONER CUTTER	07/06/2023	490.24	490.24	07/19/2023
10-81-533 SMALL TOOLS/HARDWARE	5363	LEE TOOLS LLC	3957	AUTOMATIC WIRE STRIPPER	07/13/2023	136.33	136.33	07/19/2023
10-81-533 SMALL TOOLS/HARDWARE	5533	MAC TOOLS	D 58333	S/D FOAM SET GREEN	07/25/2023	185.45	185.45	07/26/2023
10-81-533 SMALL TOOLS/HARDWARE	5533	MAC TOOLS	D57804	BATTERY	06/27/2023	447.28	447.28	07/13/2023
10-81-533 SMALL TOOLS/HARDWARE	5533	MAC TOOLS	D58047	TOOLS	07/11/2023	266.16	266.16	07/13/2023
10-81-533 SMALL TOOLS/HARDWARE	5788	MITCHELL 1	IB29483262	WEB TEAMWORKS	06/19/2023	263.67	263.67	07/06/2023
Total 10-81-533 SMALL TOOLS/HARDWARE:						2,334.46	2,334.46	
10-81-540 OFFICE SUPPLIES								
10-81-540 OFFICE SUPPLIES	2469	BMO HARRIS MASTERCARD	07237364	WALGREENS	07/05/2023	10.90	10.90	07/26/2023
Total 10-81-540 OFFICE SUPPLIES:						10.90	10.90	
10-81-541 EQUIPMENT SUPPLIES								
10-81-541 EQUIPMENT SUPPLIES	2469	BMO HARRIS MASTERCARD	07237364	HARBOR FREIGHT - SUPPLIES	07/05/2023	102.44	102.44	07/26/2023
10-81-541 EQUIPMENT SUPPLIES	2469	BMO HARRIS MASTERCARD	07237364	TRACTOR SUPPLY - RSE CHAR	07/05/2023	74.04	74.04	07/26/2023
Total 10-81-541 EQUIPMENT SUPPLIES:						176.48	176.48	
10-81-543 CLEANING SUPPLIES								
10-81-543 CLEANING SUPPLIES	2469	BMO HARRIS MASTERCARD	07237364	TRUCK PRO - DEGREASER	07/05/2023	150.00	150.00	07/26/2023

GL Account and Title	Vendor	Vendor Name	Invoice Number	Description	Invoice Date	Net Invoice Amount	Amount Paid	Date Paid
Total 10-81-543 CLEANING SUPPLIES:						150.00	150.00	
10-81-550 VEHICLE SUPPLIES								
10-81-550 VEHICLE SUPPLIES	8360	WINZER	1185129	SAE FUEL LINE	06/27/2023	58.77	58.77	07/26/2023
Total 10-81-550 VEHICLE SUPPLIES:						58.77	58.77	
10-81-553 TIRES/BATTERIES								
10-81-553 TIRES/BATTERIES	3075	FIRST CALL AUTO PARTS	2752-173154	BATTERY	06/21/2023	218.30	218.30	07/26/2023
10-81-553 TIRES/BATTERIES	3075	FIRST CALL AUTO PARTS	2752-173171	CORE RETURN	06/21/2023	218.30-	218.30-	07/26/2023
Total 10-81-553 TIRES/BATTERIES:						.00	.00	
10-81-555 GAS/OIL/LUBRICANTS								
10-81-555 GAS/OIL/LUBRICANTS	1396	AMSOIL INC	21721296	5W30	06/29/2023	485.32	485.32	07/06/2023
10-81-555 GAS/OIL/LUBRICANTS	7945	SENERGY PETROLEUM	SEN-581667	GAS/DIESEL	07/12/2023	895.94	895.94	07/19/2023
10-81-555 GAS/OIL/LUBRICANTS	7945	SENERGY PETROLEUM	SEN-581667	DYED ULSD #2	07/12/2023	1,502.15	1,502.15	07/19/2023
10-81-555 GAS/OIL/LUBRICANTS	7317	SOUTHWESTERN WYNN'S PRO	2822	RETURN	06/20/2023	217.83-	217.83-	07/06/2023
10-81-555 GAS/OIL/LUBRICANTS	7317	SOUTHWESTERN WYNN'S PRO	2822	2822	06/20/2023	178.24	178.24	07/06/2023
Total 10-81-555 GAS/OIL/LUBRICANTS:						2,843.82	2,843.82	
10-81-741 MACHINERY/EQUIPMENT								
10-81-741 MACHINERY/EQUIPMENT	7232	SNAP ON TOOLS	07062313581	AC RECOVERY & CHARGE MAC	07/06/2023	22,170.98	22,170.98	07/19/2023
10-81-741 MACHINERY/EQUIPMENT	8360	WINZER	1191000	SPLIT LOOM	06/29/2023	67.93	67.93	07/26/2023
Total 10-81-741 MACHINERY/EQUIPMENT:						22,238.91	22,238.91	
10-81-750 VEHICLES								
10-81-750 VEHICLES	4042	ENTERPRISE FLEET MANAGEM	FBN4788216	SHOP - THATCHER	07/06/2023	642.15	642.15	07/19/2023
Total 10-81-750 VEHICLES:						642.15	642.15	
10-84-150 ASP LABOR								
10-84-150 ASP LABOR	1930	ARIZONA STATE PRISON - SAF	S01527723062	LABOR	06/29/2023	.00	.00	
10-84-150 ASP LABOR	1930	ARIZONA STATE PRISON - SAF	S01530423070	LABOR	07/14/2023	.00	.00	
10-84-150 ASP LABOR	1930	ARIZONA STATE PRISON - SAF	TOT23-26	LABOR	07/14/2023	.00	.00	
Total 10-84-150 ASP LABOR:						.00	.00	

GL Account and Title	Vendor	Vendor Name	Invoice Number	Description	Invoice Date	Net Invoice Amount	Amount Paid	Date Paid
10-84-310 TELEPHONE								
10-84-310 TELEPHONE	8130	VALLEY TELECOM	33664002/0701	TELEPHONE	07/01/2023	111.15	111.15	07/13/2023
Total 10-84-310 TELEPHONE:						111.15	111.15	
10-84-311 CELL PHONES & AIR CARDS								
10-84-311 CELL PHONES & AIR CARD	7827	TRANSWORLD NETWORK COR	15589095-A6	INTERNET	07/16/2023	6.62	6.62	07/26/2023
10-84-311 CELL PHONES & AIR CARD	8195	VERIZON WIRELESS	9938209028	AIR CARDS/CELL	06/26/2023	129.50	129.50	07/13/2023
Total 10-84-311 CELL PHONES & AIR CARDS:						136.12	136.12	
10-84-349 EQUIPMENT RENTALS								
10-84-349 EQUIPMENT RENTALS	4000	EMPIRE SOUTHWEST	EMRA0036470	RENTAL	05/30/2023	1,171.73	1,171.73	07/06/2023
Total 10-84-349 EQUIPMENT RENTALS:						1,171.73	1,171.73	
10-84-350 VEHICLE MAINTENANCE								
10-84-350 VEHICLE MAINTENANCE	2469	BMO HARRIS MASTERCARD	07237364	CARPARTS.COM	07/05/2023	115.17	115.17	07/26/2023
10-84-350 VEHICLE MAINTENANCE	4000	EMPIRE SOUTHWEST	EMPC0837548	RETURN	06/19/2023	858.22-	858.22-	07/06/2023
10-84-350 VEHICLE MAINTENANCE	4000	EMPIRE SOUTHWEST	EMPS5983437	FILTER	05/23/2023	111.71	111.71	07/06/2023
10-84-350 VEHICLE MAINTENANCE	4000	EMPIRE SOUTHWEST	EMPS5984863	ELEMENT/OIL TODTO 50	05/24/2023	230.04	230.04	07/06/2023
10-84-350 VEHICLE MAINTENANCE	4000	EMPIRE SOUTHWEST	EMPS6003018	CUSHION	06/12/2023	858.22	858.22	07/06/2023
10-84-350 VEHICLE MAINTENANCE	4000	EMPIRE SOUTHWEST	RLOK184389	PAYMENT	06/05/2023	3,357.60-	3,357.60-	07/06/2023
10-84-350 VEHICLE MAINTENANCE	4000	EMPIRE SOUTHWEST	RV1711166	RETURN	05/23/2023	844.43-	844.43-	07/06/2023
10-84-350 VEHICLE MAINTENANCE	4038	ENGLAND & SON	303189	AXLE	07/10/2023	293.15	293.15	07/19/2023
10-84-350 VEHICLE MAINTENANCE	3075	FIRST CALL AUTO PARTS	2752-167643	BATTERY	05/30/2023	190.83	190.83	07/26/2023
10-84-350 VEHICLE MAINTENANCE	3075	FIRST CALL AUTO PARTS	2752-172947	RTD BELT	06/20/2023	21.48	21.48	07/26/2023
10-84-350 VEHICLE MAINTENANCE	5530	MACK'S AUTO SUPPLY	144272	HYD HOSE	06/19/2023	347.04	347.04	07/19/2023
Total 10-84-350 VEHICLE MAINTENANCE:						2,892.61-	2,892.61-	
10-84-505 TRAINING/MEETING/TRAVEL								
10-84-505 TRAINING/MEETING/TRAVE	2469	BMO HARRIS MASTERCARD	07231979	HOME DEPOT - TOOLS	07/05/2023	287.25	287.25	07/26/2023
Total 10-84-505 TRAINING/MEETING/TRAVEL:						287.25	287.25	
10-84-542 BLDG MATERIALS/SUPPLIES								
10-84-542 BLDG MATERIALS/SUPPLIE	2469	BMO HARRIS MASTERCARD	07238854	HOME DEPOT - PARTS	07/05/2023	135.88	135.88	07/26/2023
Total 10-84-542 BLDG MATERIALS/SUPPLIES:						135.88	135.88	

GL Account and Title	Vendor	Vendor Name	Invoice Number	Description	Invoice Date	Net Invoice Amount	Amount Paid	Date Paid
10-84-553 TIRES/BATTERIES								
10-84-553 TIRES/BATTERIES	3075	FIRST CALL AUTO PARTS	2752-172622	CORE RETURN	06/19/2023	136.38-	136.38-	07/26/2023
10-84-553 TIRES/BATTERIES	3075	FIRST CALL AUTO PARTS	2752-172625	CORE RETURN	06/19/2023	30.55-	30.55-	07/26/2023
Total 10-84-553 TIRES/BATTERIES:						166.93-	166.93-	
10-84-555 GAS/OIL/LUBRICANTS								
10-84-555 GAS/OIL/LUBRICANTS	7945	SENERGY PETROLEUM	SEN-581667	GAS/DIESEL	07/12/2023	1,673.66	1,673.66	07/19/2023
Total 10-84-555 GAS/OIL/LUBRICANTS:						1,673.66	1,673.66	
10-84-590 MISCELLANEOUS								
10-84-590 MISCELLANEOUS	8130	VALLEY TELECOM	33664002/0701	DAMAGE FACILITIES REPAIR	07/01/2023	1,044.80	1,044.80	07/13/2023
Total 10-84-590 MISCELLANEOUS:						1,044.80	1,044.80	
10-84-665 DRAINAGE								
10-84-665 DRAINAGE	2469	BMO HARRIS MASTERCARD	07230918	HOME DEPOT - FENCE	07/05/2023	101.82	101.82	07/26/2023
10-84-665 DRAINAGE	3145	CKC MATERIALS DIVISION	C1980	1ST AVE	06/30/2023	618.28	618.28	07/13/2023
10-84-665 DRAINAGE	6165	PACIFIC CORRUGATED PIPE C	S1457063	DRAIN PIPE	07/11/2023	14,506.62	14,506.62	07/19/2023
10-84-665 DRAINAGE	6880	SAFFORD BUILDERS SUPPLY C	970272	1ST AVE	05/30/2023	437.17	437.17	07/06/2023
10-84-665 DRAINAGE	6880	SAFFORD BUILDERS SUPPLY C	970612	1ST AVE	06/01/2023	95.52	95.52	07/06/2023
10-84-665 DRAINAGE	6880	SAFFORD BUILDERS SUPPLY C	970861	1ST AVE	06/05/2023	26.94	26.94	07/06/2023
10-84-665 DRAINAGE	6953	SAFFORD STONE COMPANY LL	2318	MATERIALS AND LABOR	05/26/2023	5,000.00	5,000.00	07/13/2023
Total 10-84-665 DRAINAGE:						20,786.35	20,786.35	
10-84-741 MACHINERY/EQUIPMENT								
10-84-741 MACHINERY/EQUIPMENT	2469	BMO HARRIS MASTERCARD	07230918	HOME DEPOT - FENCE	07/05/2023	719.80	719.80	07/26/2023
10-84-741 MACHINERY/EQUIPMENT	2469	BMO HARRIS MASTERCARD	07230918	HOME DEPOT - FENCE	07/05/2023	46.22	46.22	07/26/2023
10-84-741 MACHINERY/EQUIPMENT	2469	BMO HARRIS MASTERCARD	07230918	HOME DEPOT - HIGH SCHOOL	07/05/2023	173.09	173.09	07/26/2023
10-84-741 MACHINERY/EQUIPMENT	2469	BMO HARRIS MASTERCARD	07238255	HOME DEPOT - FENCE	07/05/2023	65.39	65.39	07/26/2023
10-84-741 MACHINERY/EQUIPMENT	4000	EMPIRE SOUTHWEST	EMSL0007797	S9655001	06/16/2023	3,342.13	3,342.13	07/06/2023
10-84-741 MACHINERY/EQUIPMENT	6025	NORTHERN TOOL & EQUIPMEN	545600978	WELDING SUPPLIES	06/20/2023	844.69	844.69	07/19/2023
Total 10-84-741 MACHINERY/EQUIPMENT:						5,191.32	5,191.32	
10-84-750 VEHICLES								
10-84-750 VEHICLES	4042	ENTERPRISE FLEET MANAGEM	FBN4788216	STREETS - KAY	07/06/2023	788.95	788.95	07/19/2023
10-84-750 VEHICLES	4042	ENTERPRISE FLEET MANAGEM	FBN4788216	STREETS - FERRIN	07/06/2023	793.73	793.73	07/19/2023
10-84-750 VEHICLES	4042	ENTERPRISE FLEET MANAGEM	FBN4788216	STREETS - AJEMAN	07/06/2023	782.65	782.65	07/19/2023

GL Account and Title	Vendor	Vendor Name	Invoice Number	Description	Invoice Date	Net Invoice Amount	Amount Paid	Date Paid
Total 10-84-750 VEHICLES:						2,365.33	2,365.33	
10-85-310 TELEPHONE								
10-85-310 TELEPHONE	8130	VALLEY TELECOM	33664002/0701	TELEPHONE	07/01/2023	146.88	146.88	07/13/2023
Total 10-85-310 TELEPHONE:						146.88	146.88	
10-85-311 CELL PHONE & AIR CARDS								
10-85-311 CELL PHONE & AIR CARDS	7827	TRANSWORLD NETWORK COR	15589095-A6	INTERNET	07/16/2023	7.99	7.99	07/26/2023
10-85-311 CELL PHONE & AIR CARDS	8195	VERIZON WIRELESS	9938209028	AIR CARDS/CELL	06/26/2023	156.10	156.10	07/13/2023
Total 10-85-311 CELL PHONE & AIR CARDS:						164.09	164.09	
10-85-325 PROFESSIONAL/TECHNICAL SERVICE								
10-85-325 PROFESSIONAL/TECHNICA	4420	GRAHAM CO BOARD OF SUPE	2024-0008	GIS SERVICES IGA	07/01/2023	3,750.00	3,750.00	07/06/2023
Total 10-85-325 PROFESSIONAL/TECHNICAL SERVICE:						3,750.00	3,750.00	
10-85-344 PRINTING/ADVERTISING								
10-85-344 PRINTING/ADVERTISING	2320	CHASE CARD SERVICES	JUNE 2023	COLUMN PBC	05/30/2023	136.86	136.86	07/19/2023
10-85-344 PRINTING/ADVERTISING	5080	DOUBLE-R COMMUNICATIONS	78-00002-0009	PRINTING & ADVERTISING	06/30/2023	42.50	42.50	07/13/2023
10-85-344 PRINTING/ADVERTISING	5080	DOUBLE-R COMMUNICATIONS	78-00009-0000	PRINTING & ADVERTISING	06/30/2023	9.90	9.90	07/13/2023
Total 10-85-344 PRINTING/ADVERTISING:						189.26	189.26	
10-85-555 GAS/OIL/LUBRICANTS								
10-85-555 GAS/OIL/LUBRICANTS	7945	SENERGY PETROLEUM	SEN-581667	GAS/DIESEL	07/12/2023	307.49	307.49	07/19/2023
Total 10-85-555 GAS/OIL/LUBRICANTS:						307.49	307.49	
10-85-590 MISCELLANEOUS								
10-85-590 MISCELLANEOUS	2469	BMO HARRIS MASTERCARD	07236101	RUSTIC BARN - BIRTHDAY	07/05/2023	33.12	33.12	07/26/2023
Total 10-85-590 MISCELLANEOUS:						33.12	33.12	
10-85-750 VEHICLES								
10-85-750 VEHICLES	4042	ENTERPRISE FLEET MANAGEM	FBN4788216	COMMUNITY DEV - ALLRED	07/06/2023	680.53	680.53	07/19/2023
Total 10-85-750 VEHICLES:						680.53	680.53	

GL Account and Title	Vendor	Vendor Name	Invoice Number	Description	Invoice Date	Net Invoice Amount	Amount Paid	Date Paid
10-87-601 RIGHT OF WAY AQUISITIONS								
10-87-601 RIGHT OF WAY AQUISITIO	4475	GRAHAM COUNTY RECORDER	2126	Recording Fee	07/03/2023	24.00	24.00	07/13/2023
10-87-601 RIGHT OF WAY AQUISITIO	10225	JUSTIN D HOUSEHOLDER	104-35-492	RIGHT OF WAY AQUISTION	07/05/2023	56,350.00	56,350.00	07/06/2023
10-87-601 RIGHT OF WAY AQUISITIO	10215	RODNEY OR NELDA PLATT	104-31-066	RIGHT OF WAY	07/11/2023	49,300.00	49,300.00	07/19/2023
10-87-601 RIGHT OF WAY AQUISITIO	10215	RODNEY OR NELDA PLATT	104-31-066	MISCALCULATION	07/11/2023	49,300.00-	49,300.00-	07/19/2023
10-87-601 RIGHT OF WAY AQUISITIO	10215	RODNEY OR NELDA PLATT	104-31-066	104-31-066	07/11/2023	49,800.00	49,800.00	07/19/2023
Total 10-87-601 RIGHT OF WAY AQUISITIONS:						106,174.00	106,174.00	
10-87-852 PARK								
10-87-852 PARK	2469	BMO HARRIS MASTERCARD	07235614	HOME DEPOT - PARTS	07/05/2023	277.62	277.62	07/26/2023
10-87-852 PARK	7820	TRI COUNTY MATERIALS INC	06/13-06/29/23	ROCK FOR SOCCER FIELDS	06/30/2023	69,953.01	69,953.01	07/13/2023
Total 10-87-852 PARK:						70,230.63	70,230.63	
10-87-853 GOLF COURSE								
10-87-853 GOLF COURSE	6037	OB SPORTS GOLF MANAGEME	23-2306	GAS JUNE 2023	06/20/2023	378.39	378.39	07/13/2023
Total 10-87-853 GOLF COURSE:						378.39	378.39	
10-89-100 INFRASTRUCTURE - ONSITE								
10-89-100 INFRASTRUCTURE - ONSIT	5447	LOGANSIMPSON	32236	RED LAMP COMMERCIAL PLAZ	07/21/2023	1,255.56	1,255.56	07/26/2023
Total 10-89-100 INFRASTRUCTURE - ONSITE:						1,255.56	1,255.56	
30-32-700 GOHS STEP GRANT 2023-PTS-066								
30-32-700 GOHS STEP GRANT 2023-P	5245	KUSTOM SIGNALS INC	25612	CUSTOM RADAR	06/05/2023	2,340.74	2,340.74	07/26/2023
Total 30-32-700 GOHS STEP GRANT 2023-PTS-066:						2,340.74	2,340.74	
30-75-600 DEMA BORDER RELATED CRIMES								
30-75-600 DEMA BORDER RELATED C	3340	CDW GOVERNMENT, INC	KK08134	TOUGH BOOKS - DEMA	06/23/2023	15,857.41	15,857.41	07/06/2023
30-75-600 DEMA BORDER RELATED C	3340	CDW GOVERNMENT, INC	KL68614	VEHICLE DOCK - DEMA	06/28/2023	13,040.02	13,040.02	07/06/2023
30-75-600 DEMA BORDER RELATED C	4156	FLOCK SAFETY	INV-12751	FALCON/FALCON FLEX	03/03/2023	15,583.00	15,583.00	07/06/2023
Total 30-75-600 DEMA BORDER RELATED CRIMES:						44,480.43	44,480.43	
45-83-334 LANDFILL COSTS								
45-83-334 LANDFILL COSTS	4302	CITY OF SAFFORD	1.432.01/06302	LANDFILL	06/30/2023	11,808.54	11,808.54	07/13/2023

GL Account and Title	Vendor	Vendor Name	Invoice Number	Description	Invoice Date	Net Invoice Amount	Amount Paid	Date Paid
Total 45-83-334 LANDFILL COSTS:						11,808.54	11,808.54	
45-83-341 EQUIPMENT MAINTENANCE								
45-83-341 EQUIPMENT MAINTENANC	2469	BMO HARRIS MASTERCARD	07237364	ZORO - SWITCH	07/05/2023	14.86	14.86	07/26/2023
45-83-341 EQUIPMENT MAINTENANC	2469	BMO HARRIS MASTERCARD	07237364	ZORO - SWITCH	07/05/2023	123.99	123.99	07/26/2023
45-83-341 EQUIPMENT MAINTENANC	5530	MACK'S AUTO SUPPLY	144917	HYD HOSE	06/22/2023	103.60	103.60	07/19/2023
45-83-341 EQUIPMENT MAINTENANC	5530	MACK'S AUTO SUPPLY	145473	CABLE	06/26/2023	128.51	128.51	07/19/2023
Total 45-83-341 EQUIPMENT MAINTENANCE:						370.96	370.96	
45-83-350 VEHICLE MAINTENANCE								
45-83-350 VEHICLE MAINTENANCE	2469	BMO HARRIS MASTERCARD	07237364	EBAY - OLD MACK	07/05/2023	45.97	45.97	07/26/2023
45-83-350 VEHICLE MAINTENANCE	2469	BMO HARRIS MASTERCARD	07237364	TEXAS TRUCK - A/C	07/05/2023	129.23	129.23	07/26/2023
45-83-350 VEHICLE MAINTENANCE	3075	FIRST CALL AUTO PARTS	2752-174805	FAN CLUTCH	06/27/2023	119.25	119.25	07/26/2023
45-83-350 VEHICLE MAINTENANCE	5529	MCNEILUS TRUCK & MFG. CO.	5952010	SENSOR	07/12/2023	430.31	430.31	07/19/2023
Total 45-83-350 VEHICLE MAINTENANCE:						724.76	724.76	
45-83-555 GAS/OIL/LUBRICANTS								
45-83-555 GAS/OIL/LUBRICANTS	7945	SENERGY PETROLEUM	SEN-581667	GAS/DIESEL	07/12/2023	1,752.04	1,752.04	07/19/2023
Total 45-83-555 GAS/OIL/LUBRICANTS:						1,752.04	1,752.04	
45-83-750 VEHICLES								
45-83-750 VEHICLES	4042	ENTERPRISE FLEET MANAGEM	FBN4788216	SEWER - WES	07/06/2023	786.68	786.68	07/19/2023
Total 45-83-750 VEHICLES:						786.68	786.68	
50-86-150 ASP LABOR								
50-86-150 ASP LABOR	1930	ARIZONA STATE PRISON - SAF	S01527723062	LABOR	06/29/2023	.00	.00	
50-86-150 ASP LABOR	1930	ARIZONA STATE PRISON - SAF	S01530423070	LABOR	07/14/2023	.00	.00	
50-86-150 ASP LABOR	1930	ARIZONA STATE PRISON - SAF	TOT23-26	LABOR	07/14/2023	.00	.00	
Total 50-86-150 ASP LABOR:						.00	.00	
50-86-310 TELEPHONE								
50-86-310 TELEPHONE	8130	VALLEY TELECOM	33664002/0701	TELEPHONE	07/01/2023	73.44	73.44	07/13/2023
Total 50-86-310 TELEPHONE:						73.44	73.44	

GL Account and Title	Vendor	Vendor Name	Invoice Number	Description	Invoice Date	Net Invoice Amount	Amount Paid	Date Paid
50-86-311 CELL PHONES & AIR CARDS								
50-86-311 CELL PHONES & AIR CARD	7827	TRANSWORLD NETWORK COR	15589095-A6	INTERNET	07/16/2023	1.36	1.36	07/26/2023
50-86-311 CELL PHONES & AIR CARD	8195	VERIZON WIRELESS	9938209028	AIR CARDS/CELL	06/26/2023	26.61	26.61	07/13/2023
Total 50-86-311 CELL PHONES & AIR CARDS:						27.97	27.97	
50-86-326 ATTORNEY								
50-86-326 ATTORNEY	5667	MATT N. CLIFFORD, P.C.	JULY 2023	SEWER	07/05/2023	566.59	566.59	07/06/2023
Total 50-86-326 ATTORNEY:						566.59	566.59	
50-86-347 COMPUTER SOFTWARE SUPPORT								
50-86-347 COMPUTER SOFTWARE S	2905	CASELLE, INC.	125728	SOFTWARE SUPPORT	07/01/2023	406.00	406.00	07/06/2023
Total 50-86-347 COMPUTER SOFTWARE SUPPORT:						406.00	406.00	
50-86-370 LAGOON MAINTENANCE								
50-86-370 LAGOON MAINTENANCE	6250	PETTY CASH	071923	PUMP REPAIR	07/19/2023	29.00	29.00	07/26/2023
Total 50-86-370 LAGOON MAINTENANCE:						29.00	29.00	
50-86-505 TRAINING/MEETING/TRAVEL								
50-86-505 TRAINING/MEETING/TRAVE	2469	BMO HARRIS MASTERCARD	07235671	LITTLE AMERICAN HOTEL	07/05/2023	306.86	306.86	07/26/2023
Total 50-86-505 TRAINING/MEETING/TRAVEL:						306.86	306.86	
50-86-520 UTILITIY BILLS								
50-86-520 UTILITIY BILLS	4184	FREEDOM MAILING SERVICES,	45679	OUTSOURCE BILLING	07/05/2023	159.60	159.60	07/13/2023
Total 50-86-520 UTILITIY BILLS:						159.60	159.60	
50-86-555 GAS/OIL/LUBRICANTS								
50-86-555 GAS/OIL/LUBRICANTS	7945	SENERGY PETROLEUM	SEN-581667	GAS/DIESEL	07/12/2023	572.05	572.05	07/19/2023
Total 50-86-555 GAS/OIL/LUBRICANTS:						572.05	572.05	
50-86-590 MISCELLANEOUS								
50-86-590 MISCELLANEOUS	2469	BMO HARRIS MASTERCARD	07235671	HOME DEPOT - SUPPLIES	07/05/2023	23.31	23.31	07/26/2023
Total 50-86-590 MISCELLANEOUS:						23.31	23.31	

GL Account and Title	Vendor	Vendor Name	Invoice Number	Description	Invoice Date	Net Invoice Amount	Amount Paid	Date Paid
50-86-748 COMPUTER SUPPORT								
50-86-748 COMPUTER SUPPORT	3435	DAN MARTIN	JULY 2023	IT CONSULTING	07/03/2023	558.00	558.00	07/06/2023
Total 50-86-748 COMPUTER SUPPORT:						558.00	558.00	
55-33-800 OVERAGES/SHORTS								
55-33-800 OVERAGES/SHORTS	6250	PETTY CASH	071923	SHORT	07/19/2023	4.00	4.00	07/26/2023
Total 55-33-800 OVERAGES/SHORTS:						4.00	4.00	
55-88-150 ASP LABOR								
55-88-150 ASP LABOR	1930	ARIZONA STATE PRISON - SAF	S01527723062	LABOR	06/29/2023	.00	.00	
55-88-150 ASP LABOR	1930	ARIZONA STATE PRISON - SAF	S01530423070	LABOR	07/14/2023	.00	.00	
55-88-150 ASP LABOR	1930	ARIZONA STATE PRISON - SAF	TOT23-26	LABOR	07/14/2023	.00	.00	
Total 55-88-150 ASP LABOR:						.00	.00	
55-88-310 TELEPHONE								
55-88-310 TELEPHONE	8130	VALLEY TELECOM	33664002/0701	TELEPHONE	07/01/2023	218.35	218.35	07/13/2023
Total 55-88-310 TELEPHONE:						218.35	218.35	
55-88-311 CELL PHONES & AIR PLUGS								
55-88-311 CELL PHONES & AIR PLUG	7827	TRANSWORLD NETWORK COR	15589095-A6	INTERNET	07/16/2023	7.99	7.99	07/26/2023
55-88-311 CELL PHONES & AIR PLUG	8195	VERIZON WIRELESS	9938209028	AIR CARDS/CELL	06/26/2023	156.10	156.10	07/13/2023
Total 55-88-311 CELL PHONES & AIR PLUGS:						164.09	164.09	
55-88-325 PROFESSIONAL/TECHNICAL SERVICE								
55-88-325 PROFESSIONAL/TECHNICA	5235	K.R. SALINE & ASSOCIATES, PL	2947	CONSULTING SERVICES	07/07/2023	658.90	658.90	07/13/2023
Total 55-88-325 PROFESSIONAL/TECHNICAL SERVICE:						658.90	658.90	
55-88-344 PRINTING/ADVERTISING								
55-88-344 PRINTING/ADVERTISING	2320	CHASE CARD SERVICES	JUNE 2023	COLUMN PBC	05/30/2023	75.54	75.54	07/19/2023
55-88-344 PRINTING/ADVERTISING	5080	DOUBLE-R COMMUNICATIONS	78-00002-0009	PRINTING & ADVERTISING	06/30/2023	29.75	29.75	07/13/2023
55-88-344 PRINTING/ADVERTISING	5080	DOUBLE-R COMMUNICATIONS	78-00009-0000	PRINTING & ADVERTISING	06/30/2023	6.93	6.93	07/13/2023
Total 55-88-344 PRINTING/ADVERTISING:						112.22	112.22	

GL Account and Title	Vendor	Vendor Name	Invoice Number	Description	Invoice Date	Net Invoice Amount	Amount Paid	Date Paid
55-88-347 COMPUTER SOFTWARE SUPPORT								
55-88-347	COMPUTER SOFTWARE S	2905 CASELLE, INC.	125728	SOFTWARE SUPPORT	07/01/2023	406.00	406.00	07/06/2023
Total 55-88-347 COMPUTER SOFTWARE SUPPORT:						406.00	406.00	
55-88-381 ELECTRICAL SYSTEM WHEELING								
55-88-381	ELECTRICAL SYSTEM WHE	7355 ARIZONA ELECTRIC POWER C	JUNE, 2023	TRANSMISSION SERVICES	07/10/2023	31,171.01	31,171.01	07/13/2023
55-88-381	ELECTRICAL SYSTEM WHE	4406 GRAHAM CO UTILITIES	JUNE 2023	WHEELING	07/11/2023	114,123.00	114,123.00	07/13/2023
55-88-381	ELECTRICAL SYSTEM WHE	7333 SOUTHWEST PUBLIC POWER	5249-2	NATURAL GAS HEDGING	07/01/2023	22,500.00	22,500.00	07/19/2023
Total 55-88-381 ELECTRICAL SYSTEM WHEELING:						167,794.01	167,794.01	
55-88-385 PURCHASE OF POWER								
55-88-385	PURCHASE OF POWER	1885 ARIZONA POWER AUTHORITY	OY2023-0637	PURCHASE OF POWER	07/03/2023	3,309.28	3,309.28	07/13/2023
55-88-385	PURCHASE OF POWER	2728 BUREAU OF RECLAMATION	91082149	ADVANCE FUNDS CONTRACT	07/15/2023	2,458.10	2,458.10	07/19/2023
55-88-385	PURCHASE OF POWER	7333 SOUTHWEST PUBLIC POWER	5858	JUNE INDEX SWAP	07/07/2023	5,927.17	5,927.17	07/13/2023
55-88-385	PURCHASE OF POWER	8005 US DEPARTMENT OF ENERGY	1011675	PARKER DAVIS FIRM ELECTRIC	06/30/2023	7,756.87	7,756.87	07/13/2023
55-88-385	PURCHASE OF POWER	8005 US DEPARTMENT OF ENERGY	1011816	POINT TO POINT TRANSMISSIO	07/03/2023	621.81	621.81	07/13/2023
55-88-385	PURCHASE OF POWER	8005 US DEPARTMENT OF ENERGY	GG1229B0623	PURCHASE OF POWER	07/06/2023	2,439.00	2,439.00	07/13/2023
55-88-385	PURCHASE OF POWER	8005 US DEPARTMENT OF ENERGY	JJPB1229A062	PURCHASE OF POWER	07/18/2023	5,391.85	5,391.85	07/19/2023
Total 55-88-385 PURCHASE OF POWER:						27,904.08	27,904.08	
55-88-426 ATTORNEY								
55-88-426	ATTORNEY	5667 MATT N. CLIFFORD, P.C.	JULY 2023	ELECTRIC	07/05/2023	453.07	453.07	07/06/2023
Total 55-88-426 ATTORNEY:						453.07	453.07	
55-88-505 TRAINING/MEETING/TRAVEL								
55-88-505	TRAINING/MEETING/TRAVE	2469 BMO HARRIS MASTERCARD	07236101	AC HOTEL	07/05/2023	1,125.65	1,125.65	07/26/2023
55-88-505	TRAINING/MEETING/TRAVE	2469 BMO HARRIS MASTERCARD	07236101	CHEVRON	07/05/2023	49.50	49.50	07/26/2023
Total 55-88-505 TRAINING/MEETING/TRAVEL:						1,175.15	1,175.15	
55-88-510 DUES/SUBSCRIPTIONS								
55-88-510	DUES/SUBSCRIPTIONS	1840 ARIZONA MUNICIPAL POWER U	070123-09302	Dues/Subscriptions	07/01/2023	750.00	750.00	07/06/2023
55-88-510	DUES/SUBSCRIPTIONS	1840 ARIZONA MUNICIPAL POWER U	CREDA 07012	Dues/Subscriptions	07/01/2023	9.00	9.00	07/06/2023
Total 55-88-510 DUES/SUBSCRIPTIONS:						759.00	759.00	

GL Account and Title	Vendor	Vendor Name	Invoice Number	Description	Invoice Date	Net Invoice Amount	Amount Paid	Date Paid
55-88-520 UTILITY BILLS								
55-88-520 UTILITY BILLS	4184	FREEDOM MAILING SERVICES,	45679	OUTSOURCE BILLING	07/05/2023	159.60	159.60	07/13/2023
55-88-520 UTILITY BILLS	6052	ON LINE COLLECTIONS	206600000245	COMMISSION ON COLLECTED	06/20/2023	117.69	117.69	07/13/2023
Total 55-88-520 UTILITY BILLS:						277.29	277.29	
55-88-525 METER READING								
55-88-525 METER READING	2780	BYRAM LABORATORIES	INV2796	AMR DATA TRANSFERS	07/13/2023	1,828.75	1,828.75	07/19/2023
Total 55-88-525 METER READING:						1,828.75	1,828.75	
55-88-535 POSTAGE								
55-88-535 POSTAGE	4184	FREEDOM MAILING SERVICES,	45679	POSTAGE	07/05/2023	1,103.91	1,103.91	07/13/2023
55-88-535 POSTAGE	6355	PITNEY BOWES	060123	POSTAGE	06/01/2023	110.00	110.00	07/06/2023
Total 55-88-535 POSTAGE:						1,213.91	1,213.91	
55-88-541 EQUIPMENT SUPPLIES								
55-88-541 EQUIPMENT SUPPLIES	2469	BMO HARRIS MASTERCARD	7235580	HOME DEPOT - ADAPTERS	07/05/2023	41.31	41.31	07/26/2023
55-88-541 EQUIPMENT SUPPLIES	2469	BMO HARRIS MASTERCARD	7235580	HOME DEPOT - ADAPTERS	07/05/2023	158.72	158.72	07/26/2023
Total 55-88-541 EQUIPMENT SUPPLIES:						200.03	200.03	
55-88-555 GAS/OIL/LUBRICANTS								
55-88-555 GAS/OIL/LUBRICANTS	7945	SENERGY PETROLEUM	SEN-581667	GAS/DIESEL	07/12/2023	918.38	918.38	07/19/2023
Total 55-88-555 GAS/OIL/LUBRICANTS:						918.38	918.38	
55-88-590 MISCELLANEOUS								
55-88-590 MISCELLANEOUS	2469	BMO HARRIS MASTERCARD	7235580	HOME DEPOT - PARTS	07/05/2023	124.04	124.04	07/26/2023
55-88-590 MISCELLANEOUS	2469	BMO HARRIS MASTERCARD	7235580	HOME DEPOT - MISC	07/05/2023	34.78	34.78	07/26/2023
Total 55-88-590 MISCELLANEOUS:						158.82	158.82	
55-88-715 SAFETY EQUIPMENT								
55-88-715 SAFETY EQUIPMENT	2469	BMO HARRIS MASTERCARD	7235580	HOME DEPOT - SUPPLIES	07/05/2023	59.32	59.32	07/26/2023
55-88-715 SAFETY EQUIPMENT	4510	GRAINGER, INC	9766231337	SUPPLIES	07/11/2023	257.94	257.94	07/19/2023
Total 55-88-715 SAFETY EQUIPMENT:						317.26	317.26	

GL Account and Title	Vendor	Vendor Name	Invoice Number	Description	Invoice Date	Net Invoice Amount	Amount Paid	Date Paid
55-88-741 MACHINERY/EQUIPMENT								
55-88-741 MACHINERY/EQUIPMENT	2469	BMO HARRIS MASTERCARD	7235580	SUPPLY HOUSE - ELEC HARDW	07/05/2023	242.53	242.53	07/26/2023
55-88-741 MACHINERY/EQUIPMENT	2469	BMO HARRIS MASTERCARD	7235580	HOME DEPOT - MISC SUPPLIES	07/05/2023	127.89	127.89	07/26/2023
55-88-741 MACHINERY/EQUIPMENT	2469	BMO HARRIS MASTERCARD	7235580	SUPPLY HOUSE - ELEC HARDW	07/05/2023	167.71	167.71	07/26/2023
55-88-741 MACHINERY/EQUIPMENT	3145	CKC MATERIALS DIVISION	T4624	HIGH SCHOOL AVE	06/30/2023	3,362.47	3,362.47	07/13/2023
55-88-741 MACHINERY/EQUIPMENT	6880	SAFFORD BUILDERS SUPPLY C	971696	HS AVE ELEC PROJECT	06/13/2023	327.66	327.66	07/06/2023
55-88-741 MACHINERY/EQUIPMENT	6880	SAFFORD BUILDERS SUPPLY C	971903	HS AVE ELEC PROJECT	06/14/2023	388.51	388.51	07/06/2023
55-88-741 MACHINERY/EQUIPMENT	7820	TRI COUNTY MATERIALS INC	06/13-06/29/23	HIGH SCHOOL AVE	06/30/2023	2,680.69	2,680.69	07/13/2023
Total 55-88-741 MACHINERY/EQUIPMENT:						7,297.46	7,297.46	
55-88-748 COMPUTER SUPPORT								
55-88-748 COMPUTER SUPPORT	3435	DAN MARTIN	JULY 2023	IT CONSULTING	07/03/2023	558.00	558.00	07/06/2023
Total 55-88-748 COMPUTER SUPPORT:						558.00	558.00	
55-88-750 VEHICLES								
55-88-750 VEHICLES	4042	ENTERPRISE FLEET MANAGEM	FBN4788216	MANAGER	07/06/2023	1,202.04	1,202.04	07/19/2023
Total 55-88-750 VEHICLES:						1,202.04	1,202.04	
55-88-760 NEW CONSTRUCTION-ELEC SYSTEM								
55-88-760 NEW CONSTRUCTION-ELE	2469	BMO HARRIS MASTERCARD	07239221	TRACTOR SUPPLY - HIGH SCH	07/05/2023	152.67	152.67	07/26/2023
55-88-760 NEW CONSTRUCTION-ELE	2469	BMO HARRIS MASTERCARD	07239221	TRACTOR SUPPLY - HIGH SCH	07/05/2023	343.81	343.81	07/26/2023
55-88-760 NEW CONSTRUCTION-ELE	2469	BMO HARRIS MASTERCARD	07239221	HOME DEPOT - HIGH SCHOOL	07/05/2023	353.75	353.75	07/26/2023
55-88-760 NEW CONSTRUCTION-ELE	2469	BMO HARRIS MASTERCARD	07239221	HOME DEPOT - HIGH SCHOOL	07/05/2023	235.99	235.99	07/26/2023
55-88-760 NEW CONSTRUCTION-ELE	2469	BMO HARRIS MASTERCARD	07239221	HOME DEPOT - HIGH SCHOOL	07/05/2023	310.85	310.85	07/26/2023
Total 55-88-760 NEW CONSTRUCTION-ELEC SYSTEM:						1,397.07	1,397.07	
55-88-780 WIRE								
55-88-780 WIRE	6880	SAFFORD BUILDERS SUPPLY C	971579	HS AVE ELEC PROJECT	06/12/2023	1,690.32	1,690.32	07/06/2023
55-88-780 WIRE	6880	SAFFORD BUILDERS SUPPLY C	971584	HS AVE ELEC PROJECT	06/12/2023	127.45-	127.45-	07/06/2023
55-88-780 WIRE	6880	SAFFORD BUILDERS SUPPLY C	971850	HS AVE ELEC PROJECT	06/14/2023	78.73	78.73	07/06/2023
55-88-780 WIRE	6880	SAFFORD BUILDERS SUPPLY C	972354	HS AVE ELEC PROJECT	06/19/2023	12.95	12.95	07/06/2023
Total 55-88-780 WIRE:						1,654.55	1,654.55	
55-88-782 METERS								
55-88-782 METERS	2531	BORDER STATES ELECTRIC SU	9398502144	WIRE/METERS	05/31/2023	4,054.45	4,054.45	07/26/2023

GL Account and Title	Vendor	Vendor Name	Invoice Number	Description	Invoice Date	Net Invoice Amount	Amount Paid	Date Paid
Total 55-88-782 METERS:						4,054.45	4,054.45	
55-88-783 TRANSFORMERS								
55-88-783 TRANSFORMERS	4510	GRAINGER, INC	9756408895	CAPACITORS	06/29/2023	387.33	387.33	07/19/2023
Total 55-88-783 TRANSFORMERS:						387.33	387.33	
55-88-784 HARDWARE								
55-88-784 HARDWARE	2469	BMO HARRIS MASTERCARD	7235580	HOME DEPOT - SUPPLIES	07/05/2023	237.62	237.62	07/26/2023
55-88-784 HARDWARE	2469	BMO HARRIS MASTERCARD	7235580	HOME DEPOT - PARTS	07/05/2023	216.39	216.39	07/26/2023
55-88-784 HARDWARE	2469	BMO HARRIS MASTERCARD	7235580	HOME DEPOT - SUPPLIES	07/05/2023	469.06	469.06	07/26/2023
55-88-784 HARDWARE	2469	BMO HARRIS MASTERCARD	7235580	TRACTOR SUPPLY - PARTS	07/05/2023	81.79	81.79	07/26/2023
Total 55-88-784 HARDWARE:						1,004.86	1,004.86	
Grand Totals:						778,950.94	778,950.94	

Dated: _____

Mayor: _____

Vice Mayor: _____

Town Council: _____

Depty Clerk: _____

GL Account and Title	Vendor	Vendor Name	Invoice Number	Description	Invoice Date	Net Invoice Amount	Amount Paid	Date Paid
----------------------	--------	-------------	----------------	-------------	--------------	--------------------	-------------	-----------

Report Criteria:

- Detail report.
 - Invoices with totals above \$0.00 included.
 - Only paid invoices included.
-

TOWN OF THATCHER
 COMBINED CASH INVESTMENT
 JULY 31, 2023

COMBINED CASH ACCOUNTS

01-10100	CASH IN CHECKING - COMBINED	584,093.38
01-10150	CASH IN CHECKING - NATIONAL	6,499,489.26
01-10160	XPRESS DEPOSIT ACCOUNT	170,079.49
01-10200	PETTY CASH	500.00
01-10400	CASH IN LGIP - COMBINED	3,944,426.61
01-10460	CASH IN MORETON - COMBINED	6,059,088.21
01-10500	OVERAGE/SHORTAGES	(48.23)
01-10600	RETURNED CHECKS	1,248.79
01-10650	CONVENIENCE FEES/SERVICE FEES	(19,625.87)
01-11750	UTILITY CASH CLEARING	(32,658.62)
01-11780	IMPROVEMENT DIST CASH CLEARING	(14,455.70)
	TOTAL COMBINED CASH	17,192,137.32
01-11900	TOTAL ALLOCATION TO OTHER FUND	(17,192,137.32)
	TOTAL UNALLOCATED CASH	.00

CASH ALLOCATION RECONCILIATION

2	ALLOCATION TO FUND 02	296,409.00
3	ALLOCATION TO PAYROLL LIABILITIES	296,570.06
10	ALLOCATION TO GENERAL FUND	8,356,175.95
20	ALLOCATION TO HURF FUND	(98,578.42)
30	ALLOCATION TO MISCELLANEOUS GRANTS	5,253,526.02
41	ALLOCATION TO IMPROVEMENT DISTRICT FUND	290,171.53
45	ALLOCATION TO SANITATION ENTERPRISE FUND	(810,845.47)
50	ALLOCATION TO SEWER ENTERPRISE FUND	(1,379,389.35)
55	ALLOCATION TO ELECTRIC ENTERPRISE FUND	4,381,761.66
70	ALLOCATION TO FIREMENS PENSION FUND	22,242.96
	TOTAL ALLOCATIONS TO OTHER FUNDS	16,608,043.94
	ALLOCATION FROM COMBINED CASH FUND - 01-10100	(17,192,137.32)
	ZERO PROOF IF ALLOCATIONS BALANCE	(584,093.38)

TOWN OF THATCHER
PAYABLES CLEARING FUND ALLOCATIONS
JULY 31, 2023

<u>ACCOUNTS PAYABLE</u>		
02-20100	ACCOUNTS PAYABLE	<u>296,409.00</u>
	TOTAL ACCOUNTS PAYABLE	<u>296,409.00</u>
	TOTAL UNALLOCATED ACCOUNTS PAYABLE	<u><u>296,409.00</u></u>
<u>ACCOUNTS PAYABLE ALLOCATION RECONCILIATION</u>		
	TOTAL ALLOCATIONS TO OTHER FUNDS	<u>.00</u>
	ALLOCATION FROM PAYABLE CLEARING FUND - 02-22000	
	ZERO PROOF IF ALLOCATIONS BALANCE	<u><u>.00</u></u>

TOWN OF THATCHER
 PAYABLES CLEARING FUND ALLOCATIONS
 JULY 31, 2023

PAYROLL PAYABLES

03-20210	FICA PAYABLE	33.42
03-20215	FEDERAL WITHHOLDING PAYABLE	1,716.00
03-20220	STATE WITHHOLDING PAYABLE	10.61
03-20230	STATE RETIREMENT PAYABLE	(225.37)
03-20240	ELECTED OFFICIALS RETIREMENT	(1,822.66)
03-20300	MEDICAL INSURANCE PAYABLE	(216.10)
03-20350	WORKERS COMPENSATION PAYABLE	164,987.47
03-20380	REIMBURSEMENTS PAYABLE	132,376.69
03-20385	NON-TAXABLE DEDUCTIONS	(290.00)

TOTAL PAYROLL PAYABLES	296,570.06
------------------------	------------

TOTAL UNALLOCATED PAYROLL PAYABLES	296,570.06
------------------------------------	------------

PAYROLL PAYABLES ALLOCATION RECONCILIATION

TOTAL ALLOCATIONS TO OTHER FUNDS	.00
ALLOCATION FROM PAYABLES CLEARING FUND - 03-22900	.00

ZERO PROOF IF ALLOCATIONS BALANCE	.00
-----------------------------------	-----

TOWN OF THATCHER
BALANCE SHEET
JULY 31, 2023

GENERAL FUND

ASSETS

10-11900	CASH - COMBINED FUND	8,356,175.95	
10-13110	ACCOUNTS RECEIVABLE	80,588.00	
10-13510	TAXES RECEIVABLE - CURRENT	634,145.42	
10-14210	DUE FROM OTHER GOVERNMENTS	128,554.50	
10-15200	LEASES RECEIVABLE	895,564.03	
10-19000	DEFERRED INFLOWS OF RESOURCES	(783,988.20)	
	TOTAL ASSETS		<u>9,311,039.70</u>

LIABILITIES AND EQUITY

LIABILITIES

10-20120	DUE TO OTHER FUNDS	(.06)	
10-20200	WAGES PAYABLE	41,445.73	
10-20300	MEDICAL INSURANCE PAYABLE	(324,938.88)	
10-20320	JCEF PAYABLE	38,777.87	
10-20350	WORKERS COMPENSATION PAYABLE	26,245.00	
10-20400	DEFERRED REVENUE-FIRE DISTRICT	45,642.69	
	TOTAL LIABILITIES		(172,827.65)

FUND EQUITY

	UNAPPROPRIATED FUND BALANCE:		
10-29800	BALANCE - BEGINNING OF YEAR	9,381,215.22	
	REVENUE OVER EXPENDITURES - YTD	102,652.13	
	BALANCE - CURRENT DATE		<u>9,483,867.35</u>
	TOTAL FUND EQUITY		<u>9,483,867.35</u>
	TOTAL LIABILITIES AND EQUITY		<u>9,311,039.70</u>

TOWN OF THATCHER
REVENUES WITH COMPARISON TO BUDGET
FOR THE 1 MONTHS ENDING JULY 31, 2023

GENERAL FUND

	PERIOD ACTUAL	YTD ACTUAL	BUDGET	UNEARNED	PCNT
<u>TOWN TAXES</u>					
10-31-200 TOWN SALES TAXES	541,617.32	541,617.32	4,500,000.00	3,958,382.68	12.0
10-31-300 FRANCHISE TAXES	7,517.07	7,517.07	25,000.00	17,482.93	30.1
TOTAL TOWN TAXES	549,134.39	549,134.39	4,525,000.00	3,975,865.61	12.1
<u>INTERGOVERNMENTAL REVENUE</u>					
10-32-100 STATE SHARED-URBAN REVENUE	120,151.58	120,151.58	1,423,962.00	1,303,810.42	8.4
10-32-200 STATE SHARED-STATE SALES TAX	68,297.19	68,297.19	799,362.00	731,064.81	8.5
10-32-300 STATE SHARED AUTO LIEU	30,435.74	30,435.74	389,648.00	359,212.26	7.8
TOTAL INTERGOVERNMENTAL REVENUE	218,884.51	218,884.51	2,612,972.00	2,394,087.49	8.4
<u>CHARGES FOR SERVICES</u>					
10-33-100 CEMETERY FEES	2,000.00	2,000.00	12,000.00	10,000.00	16.7
10-33-210 TOWER RENTAL	2,398.49	2,398.49	22,000.00	19,601.51	10.9
10-33-300 JUNIOR LEAGUE BASKETBALL	.00	.00	11,000.00	11,000.00	.0
10-33-317 SWIM LEAGUE	.00	.00	2,000.00	2,000.00	.0
10-33-318 LITTLE LEAGUE WRESTLING	.00	.00	2,500.00	2,500.00	.0
10-33-321 ADULT LEAGUE BASKETBALL	.00	.00	3,600.00	3,600.00	.0
10-33-326 THS TENNIS CAMP	.00	.00	2,500.00	2,500.00	.0
10-33-330 VOLLEYBALL WOMEN	.00	.00	6,000.00	6,000.00	.0
10-33-331 JUNIOR LEAGUE VOLLEYBALL	.00	.00	3,500.00	3,500.00	.0
10-33-332 GVCMC	.00	.00	339,508.59	339,508.59	.0
10-33-350 SUMMER BASEBALL	.00	.00	27,000.00	27,000.00	.0
10-33-600 BUILDING LEASES	2,651.20	2,651.20	31,200.00	28,548.80	8.5
10-33-800 FIRE DISTRICT	.00	.00	64,896.00	64,896.00	.0
TOTAL CHARGES FOR SERVICES	7,049.69	7,049.69	527,704.59	520,654.90	1.3
<u>LICENSES/PERMITS</u>					
10-34-100 ANIMAL LICENSES	.00	.00	50.00	50.00	.0
10-34-200 BUILDING PERMITS	541.80	541.80	50,000.00	49,458.20	1.1
10-34-300 BUSINESS LICENSES	160.00	160.00	10,000.00	9,840.00	1.6
TOTAL LICENSES/PERMITS	701.80	701.80	60,050.00	59,348.20	1.2
<u>FINES/FOREITS</u>					
10-35-200 DOG IMPOUND	.00	.00	50.00	50.00	.0
10-35-500 POLICE REPORTS	35.00	35.00	200.00	165.00	17.5
TOTAL FINES/FOREITS	35.00	35.00	250.00	215.00	14.0

TOWN OF THATCHER
REVENUES WITH COMPARISON TO BUDGET
FOR THE 1 MONTHS ENDING JULY 31, 2023

GENERAL FUND

	PERIOD ACTUAL	YTD ACTUAL	BUDGET	UNEARNED	PCNT
<u>MISCELLANEOUS</u>					
10-36-100 SALE OF FIXED ASSETS	4,900.00	4,900.00	50,000.00	45,100.00	9.8
10-36-391 INSUFFICIENT FUNDS CHECKS	.00	.00	200.00	200.00	.0
10-36-400 MISCELLANEOUS	146.87	146.87	20,000.00	19,853.13	.7
10-36-600 SEWER INTERFUND TRANSFER	.00	.00	50,000.00	50,000.00	.0
TOTAL MISCELLANEOUS	5,046.87	5,046.87	120,200.00	115,153.13	4.2
<u>INTEREST ON INVESTMENTS</u>					
10-37-100 INTEREST ON LGIP INVESTMENTS	.00	.00	50,000.00	50,000.00	.0
10-37-300 INTEREST MORETON INVESTMENTS	18,375.50	18,375.50	190,000.00	171,624.50	9.7
10-37-400 GAIN/LOSS MORETON INVESTMENTS	15,213.01	15,213.01	.00	(15,213.01)	.0
TOTAL INTEREST ON INVESTMENTS	33,588.51	33,588.51	240,000.00	206,411.49	14.0
<u>SOURCE 38</u>					
10-38-100 SALE OF LOTS	.00	.00	150,000.00	150,000.00	.0
10-38-350 INFRASTRUCTURE COMPENSATION	.00	.00	300,000.00	300,000.00	.0
TOTAL SOURCE 38	.00	.00	450,000.00	450,000.00	.0
TOTAL FUND REVENUE	814,440.77	814,440.77	8,536,176.59	7,721,735.82	9.5

TOWN OF THATCHER
EXPENDITURES WITH COMPARISON TO BUDGET
FOR THE 1 MONTHS ENDING JULY 31, 2023

GENERAL FUND

	PERIOD ACTUAL	YTD ACTUAL	BUDGET	UNEXPENDED	PCNT
<u>MAYOR AND COUNCIL</u>					
10-50-102 SALARIES AND WAGES	.00	.00	42,900.00	42,900.00	.0
10-50-110 FICA	.00	.00	3,281.85	3,281.85	.0
10-50-115 RETIREMENT-ASRS	.00	.00	26,383.50	26,383.50	.0
10-50-127 WORKERS COMP INSURANCE	.00	.00	220.00	220.00	.0
10-50-250 EMPLOYEE BONUS	.00	.00	24,000.00	24,000.00	.0
10-50-280 EDUCATION REIMBURSEMENT	.00	.00	500.00	500.00	.0
10-50-302 GENERAL INSURANCE	.00	.00	4,800.00	4,800.00	.0
10-50-310 TELEPHONE	111.15	111.15	1,200.00	1,088.85	9.3
10-50-311 CELL PHONES & AIR CARDS	467.18	467.18	6,000.00	5,532.82	7.8
10-50-326 ATTORNEY	2,379.22	2,379.22	33,000.00	30,620.78	7.2
10-50-328 AUDITOR	.00	.00	50,000.00	50,000.00	.0
10-50-344 PRINTING & ADVERTISING	157.20	157.20	7,000.00	6,842.80	2.3
10-50-400 E-MAIL/WEBPAGE	.00	.00	12,000.00	12,000.00	.0
10-50-405 GIFT CERTIFICATES	.00	.00	500.00	500.00	.0
10-50-430 CHAMBER	12,000.00	12,000.00	12,000.00	.00	100.0
10-50-434 GILA WATERSHED PARTNERSHIP	.00	.00	5,000.00	5,000.00	.0
10-50-435 THATCHER ATHLETIC BOOSTER CLUB	.00	.00	550.00	550.00	.0
10-50-438 BOY SCOUTS OF AMERICA	.00	.00	100.00	100.00	.0
10-50-440 CHRISTMAS DECORATING CONTEST	.00	.00	600.00	600.00	.0
10-50-441 AMERICAN LEGION FIREWORKS	.00	.00	5,000.00	5,000.00	.0
10-50-442 SAFE HOUSE	.00	.00	5,000.00	5,000.00	.0
10-50-444 FIRST THINGS FIRST	.00	.00	1,000.00	1,000.00	.0
10-50-445 GV BOYS & GIRLS CLUB	.00	.00	2,000.00	2,000.00	.0
10-50-450 NEW BUSINESS ASSISTANCE	477.47	477.47	5,000.00	4,522.53	9.6
10-50-460 US 70 GRANT PROGRAM	2,241.27	2,241.27	20,000.00	17,758.73	11.2
10-50-505 TRAINING/MEETING/TRAVEL	(3,122.84)	(3,122.84)	9,500.00	12,622.84	(32.9)
10-50-510 DUES/SUBSCRIPTIONS	.00	.00	6,500.00	6,500.00	.0
10-50-511 LEAGUE OF CITIES/TOWNS	3,122.84	3,122.84	7,527.00	4,404.16	41.5
10-50-512 SEAGO	2,742.00	2,742.00	2,750.00	8.00	99.7
10-50-514 THATCHER SCHOOL SUMMER LIBRARY	.00	.00	4,000.00	4,000.00	.0
10-50-515 GRAHAM COUNTY FOUNDATION	.00	.00	10,000.00	10,000.00	.0
10-50-516 ADWR	.00	.00	3,000.00	3,000.00	.0
10-50-517 LIONS CLUB - VETERANS DAY	.00	.00	1,000.00	1,000.00	.0
10-50-518 FEED THE STARVING CHILDREN	.00	.00	2,500.00	2,500.00	.0
10-50-520 EAC ENGINEERING DAY	.00	.00	1,250.00	1,250.00	.0
10-50-580 CHRISTMAS DECORATIONS	.00	.00	10,000.00	10,000.00	.0
10-50-585 SUBSTANCE ABUSE COALITION	.00	.00	5,000.00	5,000.00	.0
10-50-590 MISCELLANEOUS	.00	.00	6,000.00	6,000.00	.0
10-50-600 ECONOMIC DEVELOPMENT	.00	.00	10,000.00	10,000.00	.0
10-50-740 OFFICE FURNITURE/EQUIPMENT	.00	.00	500.00	500.00	.0
10-50-750 DONATIONS	.00	.00	3,000.00	3,000.00	.0
10-50-755 COMPUTER HARDWARE	.00	.00	2,500.00	2,500.00	.0
TOTAL MAYOR AND COUNCIL	20,575.49	20,575.49	353,062.35	332,486.86	5.8

TOWN OF THATCHER
EXPENDITURES WITH COMPARISON TO BUDGET
FOR THE 1 MONTHS ENDING JULY 31, 2023

GENERAL FUND

	PERIOD ACTUAL	YTD ACTUAL	BUDGET	UNEXPENDED	PCNT
<u>ADMINISTRATION</u>					
10-52-102 SALARIES/WAGES	12,194.58	12,194.58	171,884.63	159,690.05	7.1
10-52-105 OVERTIME	.00	.00	2,000.00	2,000.00	.0
10-52-110 FICA	972.50	972.50	13,390.15	12,417.65	7.3
10-52-115 RETIREMENT-ASRS	1,516.44	1,516.44	22,725.00	21,208.56	6.7
10-52-120 HEALTH	969.37	969.37	37,800.00	36,830.63	2.6
10-52-122 HEALTH INS - ADMINISTRATION	.00	.00	1,000.00	1,000.00	.0
10-52-127 WORKERS COMP INSURANCE	117.71	117.71	1,500.00	1,382.29	7.9
10-52-130 STATE UNEMPLOYMENT	.00	.00	200.00	200.00	.0
10-52-250 EMPLOYEE BONUS	.00	.00	3,150.00	3,150.00	.0
10-52-302 GENERAL INSURANCE	.00	.00	4,500.00	4,500.00	.0
10-52-305 INSURANCE DEDUCTIBLES	.00	.00	1,500.00	1,500.00	.0
10-52-310 TELEPHONE	772.12	772.12	9,000.00	8,227.88	8.6
10-52-311 CELL PHONES & AIR CARDS	345.79	345.79	4,900.00	4,554.21	7.1
10-52-312 WATER	700.35	700.35	7,000.00	6,299.65	10.0
10-52-314 NATURAL GAS	26.72	26.72	4,000.00	3,973.28	.7
10-52-325 PROFESSIONAL TECHNICAL SERVICE	625.00	625.00	10,000.00	9,375.00	6.3
10-52-340 OFFICE EQUIPMENT MAINTENANCE	210.43	210.43	3,000.00	2,789.57	7.0
10-52-342 BUILDING MAINTENANCE	50.00	50.00	10,000.00	9,950.00	.5
10-52-344 PRINTING/ADVERTISING	589.60	589.60	7,000.00	6,410.40	8.4
10-52-347 COMPUTER SOFTWARE SUPPORT	1,646.68	1,646.68	15,000.00	13,353.32	11.0
10-52-348 COMPUTER HARDWARE MAINTENANCE	.00	.00	1,000.00	1,000.00	.0
10-52-392 BANK CHARGES	489.04	489.04	20,000.00	19,510.96	2.5
10-52-395 ELECTION SERVICES	.00	.00	3,000.00	3,000.00	.0
10-52-402 SALES TAX - OUT OF STATE	.00	.00	5,500.00	5,500.00	.0
10-52-405 PROPERTY TAXES - IRRIGATION	.00	.00	300.00	300.00	.0
10-52-505 TRAINING/MEETING/TRAVEL	456.00	456.00	14,000.00	13,544.00	3.3
10-52-510 DUES/SUBSCRIPTIONS	85.00	85.00	5,000.00	4,915.00	1.7
10-52-513 ACMA	800.00	800.00	1,000.00	200.00	80.0
10-52-528 HOLIDAY DECORATIONS	9,971.20	9,971.20	.00	(9,971.20)	.0
10-52-530 SODAS	.00	.00	500.00	500.00	.0
10-52-535 POSTAGE	.00	.00	4,600.00	4,600.00	.0
10-52-538 TREES/SHRUBS, ETC	.00	.00	1,000.00	1,000.00	.0
10-52-540 OFFICE SUPPLIES	448.09	448.09	14,000.00	13,551.91	3.2
10-52-542 BLDG MATERIALS/SUPPLIES	.00	.00	4,000.00	4,000.00	.0
10-52-543 CLEANING SUPPLIES	.00	.00	3,000.00	3,000.00	.0
10-52-548 COMPUTER SUPPLIES	.00	.00	4,000.00	4,000.00	.0
10-52-590 MISCELLANEOUS	(1,047.00)	(1,047.00)	7,500.00	8,547.00	(14.0)
10-52-740 OFFICE FURNITURE/EQUIPMENT	.00	.00	8,000.00	8,000.00	.0
10-52-747 COMPUTER SOFTWARE	5,118.67	5,118.67	9,200.00	4,081.33	55.6
10-52-748 COMPUTER SUPPORT	1,116.00	1,116.00	6,500.00	5,384.00	17.2
10-52-750 VEHICLES	399.14	399.14	4,800.00	4,400.86	8.3
TOTAL ADMINISTRATION	38,573.43	38,573.43	446,449.78	407,876.35	8.6

TOWN OF THATCHER
EXPENDITURES WITH COMPARISON TO BUDGET
FOR THE 1 MONTHS ENDING JULY 31, 2023

GENERAL FUND

	PERIOD ACTUAL	YTD ACTUAL	BUDGET	UNEXPENDED	PCNT
<u>MAGISTRATE</u>					
10-55-102 SALARIES/WAGES	20,843.54	20,843.54	274,592.61	253,749.07	7.6
10-55-105 OVERTIME	.00	.00	1,000.00	1,000.00	.0
10-55-110 FICA	1,615.94	1,615.94	21,362.06	19,746.12	7.6
10-55-115 RETIREMENT-ASRS	2,313.09	2,313.09	34,123.45	31,810.36	6.8
10-55-120 HEALTH	5,692.06	5,692.06	78,200.00	72,507.94	7.3
10-55-127 WORKERS COMP INSURANCE	146.27	146.27	800.00	653.73	18.3
10-55-250 EMPLOYEE BONUS	.00	.00	4,650.00	4,650.00	.0
10-55-302 GENERAL INSURANCE	.00	.00	1,300.00	1,300.00	.0
10-55-310 TELEPHONE	.00	.00	200.00	200.00	.0
10-55-311 CELL PHONES & AIR CARDS	280.00	280.00	3,400.00	3,120.00	8.2
10-55-312 WATER	1,151.92	1,151.92	6,500.00	5,348.08	17.7
10-55-325 PROFESSIONAL TECHNICAL SERVICE	.00	.00	100.00	100.00	.0
10-55-327 INDIGENT ATTORNEY	600.00	600.00	3,000.00	2,400.00	20.0
10-55-340 OFFICE EQUIPMENT MAINTENANCE	.00	.00	6,000.00	6,000.00	.0
10-55-505 TRAINING/MEETING/TRAVEL	.00	.00	3,000.00	3,000.00	.0
10-55-510 DUES/SUBSCRIPTIONS	25.00	25.00	1,200.00	1,175.00	2.1
10-55-535 POSTAGE	.00	.00	750.00	750.00	.0
10-55-540 OFFICE SUPPLIES	417.96	417.96	4,000.00	3,582.04	10.5
10-55-542 BUILDING MATERIALS & SUPPLIES	.00	.00	500.00	500.00	.0
10-55-548 COMPUTER MAINTENANCE	.00	.00	7,000.00	7,000.00	.0
10-55-590 MISCELLANEOUS	.00	.00	1,000.00	1,000.00	.0
TOTAL MAGISTRATE	33,085.78	33,085.78	452,678.12	419,592.34	7.3

TOWN OF THATCHER
EXPENDITURES WITH COMPARISON TO BUDGET
FOR THE 1 MONTHS ENDING JULY 31, 2023

GENERAL FUND

	PERIOD ACTUAL	YTD ACTUAL	BUDGET	UNEXPENDED	PCNT
<u>PARKS/RECREATION</u>					
10-62-102 SALARIES/WAGES	24,411.09	24,411.09	290,080.48	265,669.39	8.4
10-62-105 OVERTIME	546.26	546.26	2,000.00	1,453.74	27.3
10-62-110 FICA	1,924.55	1,924.55	22,546.88	20,622.33	8.5
10-62-115 RETIREMENT-ASRS	1,767.56	1,767.56	36,016.06	34,248.50	4.9
10-62-120 HEALTH	5,680.98	5,680.98	62,450.00	56,769.02	9.1
10-62-127 WORKERS COMP INSURANCE	773.69	773.69	8,300.00	7,526.31	9.3
10-62-150 ASP LABOR	107.69	107.69	1,500.00	1,392.31	7.2
10-62-250 EMPLOYEE BONUS	.00	.00	4,650.00	4,650.00	.0
10-62-302 GENERAL INSURANCE	.00	.00	10,000.00	10,000.00	.0
10-62-310 TELEPHONE	.00	.00	800.00	800.00	.0
10-62-311 CELL PHONES & AIR CARDS	382.53	382.53	6,500.00	6,117.47	5.9
10-62-312 WATER	2,832.79	2,832.79	22,000.00	19,167.21	12.9
10-62-317 SWIM LEAGUE	.00	.00	8,000.00	8,000.00	.0
10-62-318 LITTLE LEAGUE WRESTLING	.00	.00	3,300.00	3,300.00	.0
10-62-320 JUNIOR LEAGUE BASKETBALL	.00	.00	12,500.00	12,500.00	.0
10-62-321 ADULT LEAGUE BASKETBALL	.00	.00	8,000.00	8,000.00	.0
10-62-323 SUMMER BASEBALL	.00	.00	38,000.00	38,000.00	.0
10-62-325 PROFESSIONAL/TECHNICAL SERVICE	.00	.00	1,500.00	1,500.00	.0
10-62-326 THS TENNIS CAMP	.00	.00	2,750.00	2,750.00	.0
10-62-330 VOLLEYBALL WOMEN	.00	.00	13,100.00	13,100.00	.0
10-62-331 JUNIOR LEAGUE VOLLEYBALL	.00	.00	4,000.00	4,000.00	.0
10-62-334 TOWN EVENTS	2,867.28	2,867.28	5,000.00	2,132.72	57.4
10-62-341 EQUIPMENT MAINTENANCE	940.39	940.39	10,000.00	9,059.61	9.4
10-62-342 BUILDING MAINTENANCE	.00	.00	1,200.00	1,200.00	.0
10-62-350 VEHICLE MAINTENANCE	.00	.00	3,000.00	3,000.00	.0
10-62-505 TRAINING/MEETING/TRAVEL	.00	.00	1,000.00	1,000.00	.0
10-62-510 DUES/SUBSCRIPTIONS	.00	.00	1,000.00	1,000.00	.0
10-62-523 BASEBALL SUPPLIES	382.06	382.06	10,000.00	9,617.94	3.8
10-62-524 VOLLEYBALL SUPPLIES	.00	.00	500.00	500.00	.0
10-62-533 SMALL TOOLS/HARDWARE	48.69	48.69	2,000.00	1,951.31	2.4
10-62-537 HERBICIDES	.00	.00	8,000.00	8,000.00	.0
10-62-538 TREES, SHRUBS, ETC	.00	.00	3,000.00	3,000.00	.0
10-62-539 SEED & FERTILIZER	.00	.00	14,000.00	14,000.00	.0
10-62-540 SPLASH PAD MAINTENANCE	1,673.86	1,673.86	10,000.00	8,326.14	16.7
10-62-541 EQUIPMENT SUPPLIES	1,666.99	1,666.99	8,000.00	6,333.01	20.8
10-62-542 BLDG MATERIALS/SUPPLIES	678.36	678.36	25,000.00	24,321.64	2.7
10-62-543 CLEANING SUPPLIES	.00	.00	3,500.00	3,500.00	.0
10-62-550 VEHICLE SUPPLIES	.00	.00	500.00	500.00	.0
10-62-553 TIRES & BATTERIES	.00	.00	2,000.00	2,000.00	.0
10-62-555 GAS/OIL/LUBRICANTS	879.72	879.72	10,500.00	9,620.28	8.4
10-62-590 MISCELLANEOUS	.00	.00	2,000.00	2,000.00	.0
10-62-650 CEMETERY	469.30	469.30	10,000.00	9,530.70	4.7
10-62-667 WEED CONTROL	.00	.00	8,000.00	8,000.00	.0
10-62-730 NEW CONSTRUCTION - PARKS	.00	.00	7,500.00	7,500.00	.0
10-62-741 MACHINERY/EQUIPMENT	21,096.67	21,096.67	35,000.00	13,903.33	60.3
10-62-750 VEHICLES	1,440.81	1,440.81	17,300.00	15,859.19	8.3
TOTAL PARKS/RECREATION	70,571.27	70,571.27	755,993.42	685,422.15	9.3

TOWN OF THATCHER
EXPENDITURES WITH COMPARISON TO BUDGET
FOR THE 1 MONTHS ENDING JULY 31, 2023

GENERAL FUND

	PERIOD ACTUAL	YTD ACTUAL	BUDGET	UNEXPENDED	PCNT
<u>POLICE</u>					
10-70-102 SALARIES/WAGES	83,415.00	83,415.00	1,038,663.38	955,248.38	8.0
10-70-105 OVERTIME	2,838.36	2,838.36	25,000.00	22,161.64	11.4
10-70-110 FICA	7,612.58	7,612.58	80,452.25	72,839.67	9.5
10-70-115 RETIREMENT-ASRS	1,393.08	1,393.08	14,250.46	12,857.38	9.8
10-70-117 RETIREMENT-PSRS	28,762.21	28,762.21	378,264.35	349,502.14	7.6
10-70-120 HEALTH	24,574.47	24,574.47	357,550.00	332,975.53	6.9
10-70-127 WORKERS COMP INSURANCE	3,645.61	3,645.61	44,500.00	40,854.39	8.2
10-70-140 CLOTHING ALLOWANCE	9,200.00	9,200.00	19,200.00	10,000.00	47.9
10-70-250 EMPLOYEE BONUS	.00	.00	13,000.00	13,000.00	.0
10-70-302 GENERAL INSURANCE	.00	.00	31,000.00	31,000.00	.0
10-70-310 TELEPHONE	331.47	331.47	3,600.00	3,268.53	9.2
10-70-311 CELL PHONES & AIR CARDS	738.76	738.76	9,500.00	8,761.24	7.8
10-70-325 PROFESSIONAL/TECHNICAL SERVICE	.00	.00	14,000.00	14,000.00	.0
10-70-334 DISPATCHING	65,911.59	65,911.59	263,650.00	197,738.41	25.0
10-70-335 BODY CAMERA CONTRACT	18,383.75	18,383.75	18,500.00	116.25	99.4
10-70-340 OFFICE EQUIPMENT MAINTENANCE	.00	.00	1,000.00	1,000.00	.0
10-70-341 EQUIPMENT MAINTENANCE	.00	.00	2,000.00	2,000.00	.0
10-70-344 PRINTING/ADVERTISING	858.83	858.83	5,000.00	4,141.17	17.2
10-70-347 COMPUTER SOFTWARE SUPPORT	.00	.00	300.00	300.00	.0
10-70-350 VEHICLE MAINTENANCE	.00	.00	10,000.00	10,000.00	.0
10-70-360 ANIMAL CONTROL SERVICES	9,033.66	9,033.66	36,135.00	27,101.34	25.0
10-70-505 TRAINING/MEETING/TRAVEL	1,110.46	1,110.46	11,000.00	9,889.54	10.1
10-70-508 EXTRADITION	.00	.00	250.00	250.00	.0
10-70-509 INFORMANT & REWARD	.00	.00	1,000.00	1,000.00	.0
10-70-510 DUES/SUBSCRIPTIONS	1,750.00	1,750.00	1,500.00	(250.00)	116.7
10-70-511 GOLF COURSE MEMBERSHIP	(104.62)	(104.62)	.00	104.62	.0
10-70-515 K9	.00	.00	5,000.00	5,000.00	.0
10-70-535 POSTAGE	.00	.00	750.00	750.00	.0
10-70-540 OFFICE SUPPLIES	.00	.00	5,000.00	5,000.00	.0
10-70-541 EQUIPMENT SUPPLIES	993.95	993.95	6,000.00	5,006.05	16.6
10-70-542 BLDG MATERIALS/SUPPLIES	.00	.00	1,000.00	1,000.00	.0
10-70-543 CLEANING SUPPLIES	.00	.00	1,500.00	1,500.00	.0
10-70-544 AMMUNITION/GUN SUPPLIES	.00	.00	10,000.00	10,000.00	.0
10-70-547 ANIMAL CONTROL SUPPLIES	.00	.00	250.00	250.00	.0
10-70-549 NEIGHBORHOOD WATCH	.00	.00	1,000.00	1,000.00	.0
10-70-550 VEHICLE SUPPLIES	.00	.00	1,000.00	1,000.00	.0
10-70-553 TIRES/BATTERIES	.00	.00	3,000.00	3,000.00	.0
10-70-555 GAS/OIL/LUBRICANTS	3,130.91	3,130.91	36,000.00	32,869.09	8.7
10-70-590 MISCELLANEOUS	4.00	4.00	3,000.00	2,996.00	.1
10-70-740 OFFICE FURNITURE/EQUIPMENT	.00	.00	3,000.00	3,000.00	.0
10-70-741 MACHINERY/EQUIPMENT	.00	.00	15,000.00	15,000.00	.0
10-70-745 RADIO EQUIPMENT	.00	.00	1,000.00	1,000.00	.0
10-70-747 COMPUTER SOFTWARE	.00	.00	6,000.00	6,000.00	.0
10-70-748 COMPUTER SUPPORT	1,116.00	1,116.00	9,500.00	8,384.00	11.8
10-70-749 COMPUTER HARDWARE	.00	.00	3,000.00	3,000.00	.0
10-70-750 VEHICLES	6,112.96	6,112.96	87,900.00	81,787.04	7.0
TOTAL POLICE	270,813.03	270,813.03	2,578,215.44	2,307,402.41	10.5

TOWN OF THATCHER
EXPENDITURES WITH COMPARISON TO BUDGET
FOR THE 1 MONTHS ENDING JULY 31, 2023

GENERAL FUND

	PERIOD ACTUAL	YTD ACTUAL	BUDGET	UNEXPENDED	PCNT
<u>FIRE</u>					
10-72-116 RETIREMENT MATCH	.00	.00	5,000.00	5,000.00	.0
10-72-127 WORKERS COMP INSURANCE	.00	.00	14,000.00	14,000.00	.0
10-72-302 GENERAL INSURANCE	.00	.00	10,000.00	10,000.00	.0
10-72-310 TELEPHONE	146.88	146.88	1,600.00	1,453.12	9.2
10-72-312 WATER	122.53	122.53	1,500.00	1,377.47	8.2
10-72-320 FIRE FIGHTER CANCER FUND	13,836.02	13,836.02	13,700.00	(136.02)	101.0
10-72-340 OFFICE EQUIPMENT MAINTENANCE	.00	.00	500.00	500.00	.0
10-72-341 EQUIPMENT MAINTENANCE	.00	.00	4,000.00	4,000.00	.0
10-72-342 BUILDING MAINTENANCE	1,180.36	1,180.36	4,000.00	2,819.64	29.5
10-72-345 RADIO MAINTENANCE	.00	.00	500.00	500.00	.0
10-72-347 COMPUTER SOFTWARE SUPPORT	.00	.00	1,000.00	1,000.00	.0
10-72-348 COMPUTER HARDWARE MAINTENANCE	.00	.00	500.00	500.00	.0
10-72-350 VEHICLE MAINTENANCE	10.90	10.90	5,000.00	4,989.10	.2
10-72-505 TRAINING/MEETING/TRAVEL	.00	.00	22,000.00	22,000.00	.0
10-72-510 DUES/SUBSCRIPTIONS	.00	.00	500.00	500.00	.0
10-72-530 CLUB FUND	256.43	256.43	3,500.00	3,243.57	7.3
10-72-533 SMALL TOOLS/HARDWARE	.00	.00	1,000.00	1,000.00	.0
10-72-537 HERBICIDES	.00	.00	200.00	200.00	.0
10-72-540 OFFICE SUPPLIES	180.02	180.02	1,000.00	819.98	18.0
10-72-541 EQUIPMENT MAINTENANCE	76.31	76.31	2,500.00	2,423.69	3.1
10-72-543 CLEANING SUPPLIES	.00	.00	1,000.00	1,000.00	.0
10-72-545 RADIO SUPPLIES	.00	.00	250.00	250.00	.0
10-72-550 VEHICLE SUPPLIES	.00	.00	500.00	500.00	.0
10-72-553 TIRES/BATTERIES	.00	.00	2,500.00	2,500.00	.0
10-72-555 GAS/OIL/LUBRICANTS	710.04	710.04	9,000.00	8,289.96	7.9
10-72-590 MISCELLANEOUS	.00	.00	3,000.00	3,000.00	.0
10-72-740 OFFICE FURNITURE/EQUIP	.00	.00	1,500.00	1,500.00	.0
10-72-741 MACHINERY/EQUIPMENT	.00	.00	50,000.00	50,000.00	.0
10-72-745 RADIO EQUIPMENT	.00	.00	80,000.00	80,000.00	.0
10-72-747 COMPUTER SOFTWARE	.00	.00	750.00	750.00	.0
10-72-748 COMPUTER HARDWARE	336.00	336.00	2,000.00	1,664.00	16.8
10-72-750 VEHICLES	1,220.69	1,220.69	14,650.00	13,429.31	8.3
TOTAL FIRE	18,076.18	18,076.18	257,150.00	239,073.82	7.0

TOWN OF THATCHER
EXPENDITURES WITH COMPARISON TO BUDGET
FOR THE 1 MONTHS ENDING JULY 31, 2023

GENERAL FUND

	PERIOD ACTUAL	YTD ACTUAL	BUDGET	UNEXPENDED	PCNT
<u>SHOP</u>					
10-81-102 SALARIES/WAGES	11,843.63	11,843.63	153,967.01	142,123.38	7.7
10-81-105 OVERTIME	.00	.00	1,000.00	1,000.00	.0
10-81-110 FICA	915.20	915.20	11,931.48	11,016.28	7.7
10-81-115 RETIREMENT-ASRS	1,455.60	1,455.60	19,059.17	17,603.57	7.6
10-81-120 HEALTH	2,237.90	2,237.90	37,285.00	35,047.10	6.0
10-81-127 WORKERS COMP INSURANCE	332.88	332.88	4,100.00	3,767.12	8.1
10-81-140 CLOTHING ALLOWANCE	.00	.00	19,500.00	19,500.00	.0
10-81-150 ASP LABOR	107.68	107.68	2,000.00	1,892.32	5.4
10-81-250 EMPLOYEE BONUS	.00	.00	2,000.00	2,000.00	.0
10-81-302 GENERAL INSURANCE	.00	.00	2,800.00	2,800.00	.0
10-81-310 TELEPHONE	73.44	73.44	800.00	726.56	9.2
10-81-311 CELL PHONES & AIR CARDS	221.82	221.82	2,800.00	2,578.18	7.9
10-81-312 WATER	337.21	337.21	3,350.00	3,012.79	10.1
10-81-341 EQUIPMENT MAINTENANCE	.00	.00	8,000.00	8,000.00	.0
10-81-342 BUILDING MAINTENANCE	50.00	50.00	3,000.00	2,950.00	1.7
10-81-343 BUILDING ADDITIONS	.00	.00	67,000.00	67,000.00	.0
10-81-349 EQUIPMENT RENTALS	.00	.00	500.00	500.00	.0
10-81-350 VEHICLE MAINTENANCE	903.21	903.21	7,000.00	6,096.79	12.9
10-81-505 TRAINING/MEETING/TRAVEL	.00	.00	1,000.00	1,000.00	.0
10-81-510 DUES/SUBSCRIPTIONS	.00	.00	250.00	250.00	.0
10-81-533 SMALL TOOLS/HARDWARE	1,791.72	1,791.72	15,000.00	13,208.28	11.9
10-81-540 OFFICE SUPPLIES	50.16	50.16	1,500.00	1,449.84	3.3
10-81-541 EQUIPMENT SUPPLIES	1,034.05	1,034.05	12,000.00	10,965.95	8.6
10-81-542 BLDG MATERIALS/SUPPLIES	118.37	118.37	5,000.00	4,881.63	2.4
10-81-543 CLEANING SUPPLIES	.00	.00	3,000.00	3,000.00	.0
10-81-550 VEHICLE SUPPLIES	.00	.00	1,500.00	1,500.00	.0
10-81-553 TIRES/BATTERIES	.00	.00	3,000.00	3,000.00	.0
10-81-555 GAS/OIL/LUBRICANTS	2,514.50	2,514.50	17,000.00	14,485.50	14.8
10-81-590 MISCELLANEOUS	3.38	3.38	1,500.00	1,496.62	.2
10-81-741 MACHINERY/EQUIPMENT	22,170.98	22,170.98	21,000.00	(1,170.98)	105.6
10-81-747 COMPUTER SOFTWARE	.00	.00	1,000.00	1,000.00	.0
10-81-748 COMPUTER HARDWARE	.00	.00	1,000.00	1,000.00	.0
10-81-750 VEHICLES	642.15	642.15	7,700.00	7,057.85	8.3
TOTAL SHOP	46,803.88	46,803.88	437,542.66	390,738.78	10.7

TOWN OF THATCHER
EXPENDITURES WITH COMPARISON TO BUDGET
FOR THE 1 MONTHS ENDING JULY 31, 2023

GENERAL FUND

	PERIOD ACTUAL	YTD ACTUAL	BUDGET	UNEXPENDED	PCNT
<u>STREETS</u>					
10-84-102 SALARIES/WAGES	30,523.37	30,523.37	438,330.92	407,807.55	7.0
10-84-105 OVERTIME	266.65	266.65	3,000.00	2,733.35	8.9
10-84-110 FICA	2,381.46	2,381.46	34,182.57	31,801.11	7.0
10-84-115 RETIREMENT-ASRS	3,784.10	3,784.10	54,602.74	50,818.64	6.9
10-84-120 HEALTH	6,786.22	6,786.22	113,230.00	106,443.78	6.0
10-84-127 WORKERS COMP INSURANCE	2,724.32	2,724.32	35,000.00	32,275.68	7.8
10-84-150 ASP LABOR	.00	.00	500.00	500.00	.0
10-84-250 EMPLOYEE BONUS	.00	.00	8,500.00	8,500.00	.0
10-84-302 GENERAL INSURANCE	.00	.00	5,000.00	5,000.00	.0
10-84-310 TELEPHONE	111.15	111.15	1,200.00	1,088.85	9.3
10-84-311 CELL PHONES & AIR CARDS	485.74	485.74	6,500.00	6,014.26	7.5
10-84-325 PROFESSIONAL/TECHNICAL SERVICE	.00	.00	1,000.00	1,000.00	.0
10-84-341 EQUIPMENT MAINTENANCE	309.93	309.93	25,000.00	24,690.07	1.2
10-84-349 EQUIPMENT RENTALS	.00	.00	2,000.00	2,000.00	.0
10-84-350 VEHICLE MAINTENANCE	435.69	435.69	5,000.00	4,564.31	8.7
10-84-360 STREET MAINTENANCE	.00	.00	210,000.00	210,000.00	.0
10-84-505 TRAINING/MEETING/TRAVEL	.00	.00	4,000.00	4,000.00	.0
10-84-510 DUES/SUBSCRIPTIONS	.00	.00	250.00	250.00	.0
10-84-532 SIGNS	.00	.00	15,000.00	15,000.00	.0
10-84-533 SMALL TOOLS/HARDWARE	20.72	20.72	4,000.00	3,979.28	.5
10-84-541 EQUIPMENT SUPPLIES	130.97	130.97	9,000.00	8,869.03	1.5
10-84-542 BLDG MATERIALS/SUPPLIES	.00	.00	4,000.00	4,000.00	.0
10-84-543 CLEANING SUPPLIES	.00	.00	500.00	500.00	.0
10-84-553 TIRES/BATTERIES	.00	.00	8,000.00	8,000.00	.0
10-84-555 GAS/OIL/LUBRICANTS	1,673.66	1,673.66	24,000.00	22,326.34	7.0
10-84-590 MISCELLANEOUS	.00	.00	2,500.00	2,500.00	.0
10-84-665 DRAINAGE	14,543.48	14,543.48	30,000.00	15,456.52	48.5
10-84-667 WEED CONTROL	.00	.00	1,500.00	1,500.00	.0
10-84-741 MACHINERY/EQUIPMENT	.00	.00	80,000.00	80,000.00	.0
10-84-750 VEHICLES	2,365.33	2,365.33	28,400.00	26,034.67	8.3
TOTAL STREETS	66,542.79	66,542.79	1,154,196.23	1,087,653.44	5.8

TOWN OF THATCHER
EXPENDITURES WITH COMPARISON TO BUDGET
FOR THE 1 MONTHS ENDING JULY 31, 2023

GENERAL FUND

	PERIOD ACTUAL	YTD ACTUAL	BUDGET	UNEXPENDED	PCNT
<u>COMMUNITY DEVELOPMENT</u>					
10-85-102 SALARIES/WAGES	22,170.26	22,170.26	279,752.97	257,582.71	7.9
10-85-105 OVERTIME	180.56	180.56	1,000.00	819.44	18.1
10-85-110 FICA	1,732.78	1,732.78	21,707.10	19,974.32	8.0
10-85-115 RETIREMENT-ASRS	2,746.91	2,746.91	34,674.61	31,927.70	7.9
10-85-120 HEALTH	6,500.82	6,500.82	95,875.00	89,374.18	6.8
10-85-127 WORKERS COMP INSURANCE	394.30	394.30	5,000.00	4,605.70	7.9
10-85-250 EMPLOYEE BONUS	.00	.00	4,000.00	4,000.00	.0
10-85-302 GENERAL INSURANCE	.00	.00	10,000.00	10,000.00	.0
10-85-310 TELEPHONE	146.88	146.88	1,600.00	1,453.12	9.2
10-85-311 CELL PHONE & AIR CARDS	475.69	475.69	6,000.00	5,524.31	7.9
10-85-325 PROFESSIONAL/TECHNICAL SERVICE	3,750.00	3,750.00	22,000.00	18,250.00	17.1
10-85-341 EQUIPMENT MAINTENANCE	.00	.00	500.00	500.00	.0
10-85-344 PRINTING/ADVERTISING	52.40	52.40	2,500.00	2,447.60	2.1
10-85-348 COMPUTER HARDWARE MAINTENANCE	.00	.00	1,000.00	1,000.00	.0
10-85-350 VEHICLE MAINTENANCE	.00	.00	1,000.00	1,000.00	.0
10-85-505 TRAINING/MEETING/TRAVEL	.00	.00	5,000.00	5,000.00	.0
10-85-510 DUES/SUBSCRIPTIONS	.00	.00	1,000.00	1,000.00	.0
10-85-540 OFFICE SUPPLIES	.00	.00	1,200.00	1,200.00	.0
10-85-541 EQUIPMENT SUPPLIES	.00	.00	1,500.00	1,500.00	.0
10-85-548 COMPUTER SUPPLIES	.00	.00	500.00	500.00	.0
10-85-553 TIRES/BATTERIES	.00	.00	600.00	600.00	.0
10-85-555 GAS/OIL/LUBRICANTS	307.49	307.49	5,000.00	4,692.51	6.2
10-85-590 MISCELLANEOUS	.00	.00	1,200.00	1,200.00	.0
10-85-747 COMPUTER SOFTWARE	.00	.00	16,000.00	16,000.00	.0
10-85-748 COMPUTER HARDWARE	.00	.00	3,000.00	3,000.00	.0
10-85-750 VEHICLES	680.53	680.53	8,200.00	7,519.47	8.3
TOTAL COMMUNITY DEVELOPMENT	39,138.62	39,138.62	529,809.68	490,671.06	7.4
<u>MISCELLANEOUS EXPENSES</u>					
10-87-601 RIGHT OF WAY AQUISITIONS	105,650.00	105,650.00	250,000.00	144,350.00	42.3
10-87-850 CONTINGENCY	.00	.00	1,000,000.00	1,000,000.00	.0
10-87-852 PARK	1,958.17	1,958.17	300,000.00	298,041.83	.7
10-87-853 GOLF COURSE	.00	.00	5,000.00	5,000.00	.0
10-87-880 VAL'S BULDING MAINTENANCE	.00	.00	10,000.00	10,000.00	.0
10-87-885 DEBT SERVICE	.00	.00	95,000.00	95,000.00	.0
10-87-887 PSPRS UNFUNDED LIABILITY	.00	.00	200,000.00	200,000.00	.0
10-87-889 DOR	.00	.00	13,439.00	13,439.00	.0
TOTAL MISCELLANEOUS EXPENSES	107,608.17	107,608.17	1,873,439.00	1,765,830.83	5.7

TOWN OF THATCHER
EXPENDITURES WITH COMPARISON TO BUDGET
FOR THE 1 MONTHS ENDING JULY 31, 2023

GENERAL FUND

	PERIOD ACTUAL	YTD ACTUAL	BUDGET	UNEXPENDED	PCNT
<u>DEPARTMENT 89</u>					
10-89-100 INFRASTRUCTURE - ONSITE	.00	.00	650,000.00	650,000.00	.0
10-89-200 INFRASTRUCTURE - OFFSITE	.00	.00	120,000.00	120,000.00	.0
TOTAL DEPARTMENT 89	.00	.00	770,000.00	770,000.00	.0
TOTAL FUND EXPENDITURES	711,788.64	711,788.64	9,608,536.68	8,896,748.04	7.4
NET REVENUE OVER EXPENDITURES	102,652.13	102,652.13	(1,072,360.09)	(1,175,012.22)	9.6

TOWN OF THATCHER
 BALANCE SHEET
 JULY 31, 2023

HURF FUND

ASSETS

20-11900	CASH - COMBINED FUND	(98,578.42)	
20-13110	ACCOUNTS RECEIVABLE		47,742.62	
				<u> </u>
	TOTAL ASSETS	(50,835.80)	<u> </u>

LIABILITIES AND EQUITY

FUND EQUITY

UNAPPROPRIATED FUND BALANCE:				
20-29800	BALANCE - BEGINNING OF YEAR	(87,131.19)	
	REVENUE OVER EXPENDITURES - YTD		36,295.39	
				<u> </u>
	BALANCE - CURRENT DATE	(50,835.80)	<u> </u>
	TOTAL FUND EQUITY	(50,835.80)	<u> </u>
	TOTAL LIABILITIES AND EQUITY	(50,835.80)	<u> </u>

TOWN OF THATCHER
REVENUES WITH COMPARISON TO BUDGET
FOR THE 1 MONTHS ENDING JULY 31, 2023

HURF FUND

		PERIOD ACTUAL	YTD ACTUAL	BUDGET	UNEARNED	PCNT
<u>INTERGOVERNMENTAL REVENUE</u>						
20-32-100	HURF	36,295.39	36,295.39	537,029.00	500,733.61	6.8
	TOTAL INTERGOVERNMENTAL REVENUE	36,295.39	36,295.39	537,029.00	500,733.61	6.8
<u>INTEREST ON INVESTMENTS</u>						
20-37-100	INTEREST ON INVESTMENTS	.00	.00	15.00	15.00	.0
	TOTAL INTEREST ON INVESTMENTS	.00	.00	15.00	15.00	.0
	TOTAL FUND REVENUE	36,295.39	36,295.39	537,044.00	500,748.61	6.8

TOWN OF THATCHER
EXPENDITURES WITH COMPARISON TO BUDGET
FOR THE 1 MONTHS ENDING JULY 31, 2023

HURF FUND

	PERIOD ACTUAL	YTD ACTUAL	BUDGET	UNEXPENDED	PCNT
<u>SPECIAL REVENUE EXPENDITURES</u>					
20-80-302 GENERAL INSURANCE	.00	.00	9,000.00	9,000.00	.0
20-80-763 FOG SEAL ROADS	.00	.00	50,000.00	50,000.00	.0
20-80-771 CHIP SEAL STREETS	.00	.00	100,000.00	100,000.00	.0
20-80-772 ASPHALT MILL & OVERLAY	.00	.00	340,000.00	340,000.00	.0
20-80-850 CONTINGENCY	.00	.00	38,044.00	38,044.00	.0
TOTAL SPECIAL REVENUE EXPENDITURES	.00	.00	537,044.00	537,044.00	.0
TOTAL FUND EXPENDITURES	.00	.00	537,044.00	537,044.00	.0
NET REVENUE OVER EXPENDITURES	36,295.39	36,295.39	.00	(36,295.39)	.0

TOWN OF THATCHER
 BALANCE SHEET
 JULY 31, 2023

MISCELLANEOUS GRANTS

ASSETS

30-11900	CASH - COMBINED FUND	5,253,526.02	
30-13110	ACCOUNTS RECEIVABLE	45,087.21	
	TOTAL ASSETS		5,298,613.23

LIABILITIES AND EQUITY

FUND EQUITY

UNAPPROPRIATED FUND BALANCE:			
30-29800	BALANCE - BEGINNING OF YEAR	841,984.12	
	REVENUE OVER EXPENDITURES - YTD	4,456,629.11	
	BALANCE - CURRENT DATE	5,298,613.23	
	TOTAL FUND EQUITY		5,298,613.23
	TOTAL LIABILITIES AND EQUITY		5,298,613.23

TOWN OF THATCHER
REVENUES WITH COMPARISON TO BUDGET
FOR THE 1 MONTHS ENDING JULY 31, 2023

MISCELLANEOUS GRANTS

	PERIOD ACTUAL	YTD ACTUAL	BUDGET	UNEARNED	PCNT
<u>INTERGOVERNMENTAL REVENUE</u>					
30-32-350 8TH STREET IMPROVEMENTS A DOT	4,526,400.00	4,526,400.00	.00	(4,526,400.00)	.0
30-32-400 GFOAZ INTERNSHIP GRANT	.00	.00	6,000.00	6,000.00	.0
30-32-550 MUNICIPAL COURT ALLOC. (FTG)	.00	.00	500.00	500.00	.0
30-32-600 DEMA BORDER RELATED CRIMES	.00	.00	290,700.00	290,700.00	.0
30-32-804 STONE GARDEN	.00	.00	130,000.00	130,000.00	.0
30-32-819 POLICE DEPARTMENT GRANTS	.00	.00	10,000.00	10,000.00	.0
TOTAL INTERGOVERNMENTAL REVENUE	4,526,400.00	4,526,400.00	437,200.00	(4,089,200.00)	1035.3
TOTAL FUND REVENUE	4,526,400.00	4,526,400.00	437,200.00	(4,089,200.00)	1035.3

TOWN OF THATCHER
EXPENDITURES WITH COMPARISON TO BUDGET
FOR THE 1 MONTHS ENDING JULY 31, 2023

MISCELLANEOUS GRANTS

	PERIOD ACTUAL	YTD ACTUAL	BUDGET	UNEXPENDED	PCNT
<u>GRANT-EXPENDITURES</u>					
30-75-110 FICA	557.12	557.12	.00	(557.12)	.0
30-75-117 RETIREMENT-PSRS	1,884.90	1,884.90	.00	(1,884.90)	.0
30-75-120 HEALTH	2,240.45	2,240.45	.00	(2,240.45)	.0
30-75-127 WORKERS COMP INSURANCE	151.03	151.03	.00	(151.03)	.0
30-75-400 GFOAZ INTERNSHIP GRANT	2,523.00	2,523.00	6,000.00	3,477.00	42.1
30-75-550 MUNICIPAL COURT ALLOC.(FTG)	.00	.00	500.00	500.00	.0
30-75-600 DEMA BORDER RELATED CRIMES	53,453.95	53,453.95	290,700.00	237,246.05	18.4
30-75-700 GOHS STEP GRANT 2023-PTS-066	2,228.26	2,228.26	.00	(2,228.26)	.0
30-75-804 STONE GARDEN	5,095.56	5,095.56	130,000.00	124,904.44	3.9
30-75-810 GOHS-DUI 2023-AL-036	1,636.62	1,636.62	.00	(1,636.62)	.0
30-75-819 POLICE DEPARTMENT GRANTS	.00	.00	10,000.00	10,000.00	.0
TOTAL GRANT-EXPENDITURES	69,770.89	69,770.89	437,200.00	367,429.11	16.0
TOTAL FUND EXPENDITURES	69,770.89	69,770.89	437,200.00	367,429.11	16.0
NET REVENUE OVER EXPENDITURES	4,456,629.11	4,456,629.11	.00	(4,456,629.11)	.0

TOWN OF THATCHER
BALANCE SHEET
JULY 31, 2023

IMPROVEMENT DISTRICT FUND

<u>ASSETS</u>			
41-11900	CASH - COMBINDED FUND	290,171.53	
41-13110	ACCOUNTS RECEIVABLE	130,785.26	
	TOTAL ASSETS		420,956.79
<u>LIABILITIES AND EQUITY</u>			
<u>LIABILITIES</u>			
41-20300	DEFERRED REVENUE	131,484.33	
	TOTAL LIABILITIES		131,484.33
<u>FUND EQUITY</u>			
	UNAPPROPRIATED FUND BALANCE:		
41-29800	BALANCE - BEGINNING OF YEAR	289,472.46	
	REVENUE OVER EXPENDITURES - YTD		
	BALANCE - CURRENT DATE	289,472.46	
	TOTAL FUND EQUITY		289,472.46
	TOTAL LIABILITIES AND EQUITY		420,956.79

TOWN OF THATCHER
BALANCE SHEET
JULY 31, 2023

SANITATION ENTERPRISE FUND

ASSETS

45-11900	CASH - COMBINED FUND	(810,845.47)	
45-13110	ACCOUNTS RECEIVABLE	62,670.12	
45-13500	ALLOWANCE FOR BAD DEBT	(14,390.51)	
45-16510	MACHINERY AND EQUIPMENT	953,686.67	
45-17500	ACCUMULATED DEPRECIATION	(691,623.52)	
45-18000	NET PENSION ASSET	3,252.90	
45-19000	DEFERRED OUTFLOW OF RESOURCES	23,312.24	
	TOTAL ASSETS		(473,937.57)

LIABILITIES AND EQUITY

LIABILITIES

45-20200	WAGES PAYABLE	1,143.36	
45-23500	ACCRUED VACATIONS	8,421.49	
45-25500	NET PENSION	86,399.48	
	TOTAL LIABILITIES		95,964.33

FUND EQUITY

45-28000	DEFERRED INFLOWS OF RESOURCES	32,048.71	
	UNAPPROPRIATED FUND BALANCE:		
45-29800	BALANCE - BEGINNING OF YEAR	(610,159.25)	
	REVENUE OVER EXPENDITURES - YTD	8,208.64	
	BALANCE - CURRENT DATE	(601,950.61)	
	TOTAL FUND EQUITY		(569,901.90)
	TOTAL LIABILITIES AND EQUITY		(473,937.57)

TOWN OF THATCHER
 REVENUES WITH COMPARISON TO BUDGET
 FOR THE 1 MONTHS ENDING JULY 31, 2023

SANITATION ENTERPRISE FUND

	PERIOD ACTUAL	YTD ACTUAL	BUDGET	UNEARNED	PCNT
<u>CHARGES FOR SERVICES</u>					
45-33-300 SERVICE FEES - SANITATION	30.00	30.00	300.00	270.00	10.0
45-33-700 REFUSE COLLECTION	33,355.01	33,355.01	439,000.00	405,644.99	7.6
TOTAL CHARGES FOR SERVICES	33,385.01	33,385.01	439,300.00	405,914.99	7.6
TOTAL FUND REVENUE	33,385.01	33,385.01	439,300.00	405,914.99	7.6

TOWN OF THATCHER
EXPENDITURES WITH COMPARISON TO BUDGET
FOR THE 1 MONTHS ENDING JULY 31, 2023

SANITATION ENTERPRISE FUND

	PERIOD ACTUAL	YTD ACTUAL	BUDGET	UNEXPENDED	PCNT
<u>SANITATION</u>					
45-83-102 SALARIES & WAGES	6,074.18	6,074.18	76,381.34	70,307.16	8.0
45-83-105 OVERTIME	.00	.00	3,000.00	3,000.00	.0
45-83-110 FICA	467.74	467.74	5,919.67	5,451.93	7.9
45-83-115 RETIREMENT ASRS	746.52	746.52	9,456.00	8,709.48	7.9
45-83-120 HEALTH	1,506.68	1,506.68	24,875.00	23,368.32	6.1
45-83-127 WORKERS COMP INSURANCE	382.44	382.44	5,000.00	4,617.56	7.7
45-83-250 EMPLOYEE BONUS	.00	.00	1,000.00	1,000.00	.0
45-83-302 GENERAL INSURANCE	.00	.00	18,000.00	18,000.00	.0
45-83-311 CELL PHONES & AIR CARDS	40.00	40.00	600.00	560.00	6.7
45-83-334 LANDFILL COSTS	12,330.54	12,330.54	155,000.00	142,669.46	8.0
45-83-341 EQUIPMENT MAINTENANCE	433.80	433.80	15,000.00	14,566.20	2.9
45-83-349 EQUIPMENT RENTALS	.00	.00	1,000.00	1,000.00	.0
45-83-350 VEHICLE MAINTENANCE	430.31	430.31	30,000.00	29,569.69	1.4
45-83-505 TRAINING/MEETING/TRAVEL	.00	.00	500.00	500.00	.0
45-83-510 DUES/SUBSCRIPTIONS	.00	.00	200.00	200.00	.0
45-83-533 SMALL TOOLS/HARDWARE	.00	.00	500.00	500.00	.0
45-83-541 EQUIPMENT SUPPLIES	.00	.00	3,500.00	3,500.00	.0
45-83-543 CLEANING SUPPLIES	.00	.00	500.00	500.00	.0
45-83-553 TIRES/BATTERIES	.00	.00	5,000.00	5,000.00	.0
45-83-555 GAS/OIL/LUBRICANTS	1,977.48	1,977.48	25,000.00	23,022.52	7.9
45-83-590 MISCELLANEOUS	.00	.00	500.00	500.00	.0
45-83-743 WASTE CONTAINERS	.00	.00	15,000.00	15,000.00	.0
45-83-750 VEHICLES	786.68	786.68	362,592.68	361,806.00	.2
TOTAL SANITATION	25,176.37	25,176.37	758,524.69	733,348.32	3.3
TOTAL FUND EXPENDITURES	25,176.37	25,176.37	758,524.69	733,348.32	3.3
NET REVENUE OVER EXPENDITURES	8,208.64	8,208.64	(319,224.69)	(327,433.33)	2.6

TOWN OF THATCHER
BALANCE SHEET
JULY 31, 2023

SEWER ENTERPRISE FUND

ASSETS

50-11900	CASH - COMBINED FUND	(1,379,389.35)	
50-13110	ACCOUNTS RECEIVABLE	68,158.69	
50-13500	ALLOWANCE FOR BAD DEBT	(16,007.73)	
50-16110	LAND	248,125.50	
50-16310	SEWER SYSTEM	5,912,571.46	
50-16610	AUTOMOBILE AND TRUCKS	228,659.97	
50-17500	ACCUMULATED DEPRECIATION	(4,339,184.08)	
50-18000	NET PENSION ASSET	2,800.70	
50-19000	DEFERRED INFLOW OF RESOURCES	20,071.53	
	TOTAL ASSETS		745,806.69

LIABILITIES AND EQUITY

LIABILITIES

50-20200	WAGES PAYABLE	1,116.80	
50-23500	ACCRUED VACATIONS	2,538.20	
50-25500	NET PENSION LIAB	74,388.79	
	TOTAL LIABILITIES		78,043.79

FUND EQUITY

50-26100	CONTRIBUTED CAPITAL	153,196.72	
50-28000	DEFERRED INFLOW OF RESOURCES	27,593.51	
	UNAPPROPRIATED FUND BALANCE:		
50-29800	BALANCE - BEGINNING OF YEAR	470,000.19	
	REVENUE OVER EXPENDITURES - YTD	16,972.48	
	BALANCE - CURRENT DATE	486,972.67	
	TOTAL FUND EQUITY		667,762.90
	TOTAL LIABILITIES AND EQUITY		745,806.69

TOWN OF THATCHER
 REVENUES WITH COMPARISON TO BUDGET
 FOR THE 1 MONTHS ENDING JULY 31, 2023

SEWER ENTERPRISE FUND

	PERIOD ACTUAL	YTD ACTUAL	BUDGET	UNEARNED	PCNT
<u>CHARGES FOR SERVICES</u>					
50-33-100 SERVICE CHARGES - SEWER	36,788.26	36,788.26	435,000.00	398,211.74	8.5
50-33-150 CONNECT/RECONNECT FEES-SEWER	.00	.00	15,000.00	15,000.00	.0
TOTAL CHARGES FOR SERVICES	36,788.26	36,788.26	450,000.00	413,211.74	8.2
TOTAL FUND REVENUE	36,788.26	36,788.26	450,000.00	413,211.74	8.2

TOWN OF THATCHER
EXPENDITURES WITH COMPARISON TO BUDGET
FOR THE 1 MONTHS ENDING JULY 31, 2023

SEWER ENTERPRISE FUND

	PERIOD ACTUAL	YTD ACTUAL	BUDGET	UNEXPENDED	PCNT
<u>SEWER</u>					
50-86-102 SALARIES/WAGES	8,396.96	8,396.96	109,624.15	101,227.19	7.7
50-86-105 OVERTIME	.00	.00	1,500.00	1,500.00	.0
50-86-110 FICA	650.02	650.02	462.75	(187.27)	140.5
50-86-115 RETIREMENT	1,032.00	1,032.00	13,518.27	12,486.27	7.6
50-86-120 HEALTH	3,504.33	3,504.33	29,175.00	25,670.67	12.0
50-86-127 WORKERS COMP INSURANCE	291.00	291.00	3,000.00	2,709.00	9.7
50-86-150 ASP LABOR	.00	.00	1,000.00	1,000.00	.0
50-86-250 EMPLOYEE BONUS	.00	.00	1,000.00	1,000.00	.0
50-86-302 GENERAL INSURANCE	.00	.00	30,000.00	30,000.00	.0
50-86-310 TELEPHONE	73.44	73.44	900.00	826.56	8.2
50-86-311 CELL PHONES & AIR CARDS	129.94	129.94	1,400.00	1,270.06	9.3
50-86-325 PROFESSIONAL/TECHNICAL SERVICE	.00	.00	60,000.00	60,000.00	.0
50-86-326 ATTORNEY	566.59	566.59	7,000.00	6,433.41	8.1
50-86-333 LAB TESTING	.00	.00	5,000.00	5,000.00	.0
50-86-340 OFFICE EQUIPMENT MAINTENANCE	.00	.00	100.00	100.00	.0
50-86-341 EQUIPMENT MAINTENANCE	.00	.00	5,000.00	5,000.00	.0
50-86-347 COMPUTER SOFTWARE SUPPORT	2,617.83	2,617.83	22,000.00	19,382.17	11.9
50-86-348 COMPUTER HARDWARE	.00	.00	500.00	500.00	.0
50-86-349 EQUIPMENT RENTALS	.00	.00	1,000.00	1,000.00	.0
50-86-350 VEHICLE MAINTENANCE	.00	.00	5,000.00	5,000.00	.0
50-86-370 LAGOON MAINTENANCE	29.00	29.00	5,000.00	4,971.00	.6
50-86-371 LAGOON SUPPLIES	.00	.00	3,000.00	3,000.00	.0
50-86-505 TRAINING/MEETING/TRAVEL	(470.00)	(470.00)	2,000.00	2,470.00	(23.5)
50-86-510 DUES/SUBSCRIPTIONS	.00	.00	3,200.00	3,200.00	.0
50-86-520 UTILITY BILLS	159.60	159.60	3,700.00	3,540.40	4.3
50-86-533 SMALL TOOLS/HARDWARE	.00	.00	1,000.00	1,000.00	.0
50-86-537 HERBICIDES/PESTICIDES	1,147.02	1,147.02	8,000.00	6,852.98	14.3
50-86-541 EQUIPMENT SUPPLIES	.00	.00	2,000.00	2,000.00	.0
50-86-543 CLEANING SUPPLIES	.00	.00	1,000.00	1,000.00	.0
50-86-550 VEHICLE SUPPLIES	.00	.00	1,000.00	1,000.00	.0
50-86-553 TIRES BATTERIES	.00	.00	2,500.00	2,500.00	.0
50-86-555 GAS/OIL/LUBRICANTS	572.05	572.05	9,000.00	8,427.95	6.4
50-86-570 SEWER SYSTEM MAINTENANCE	.00	.00	5,000.00	5,000.00	.0
50-86-571 SEWER SYSTEM SUPPLIES	.00	.00	12,000.00	12,000.00	.0
50-86-590 MISCELLANEOUS	.00	.00	2,500.00	2,500.00	.0
50-86-667 WEED CONTROL	.00	.00	2,500.00	2,500.00	.0
50-86-715 SAFETY EQUIPMENT	.00	.00	1,000.00	1,000.00	.0
50-86-740 OFFICE FURNITURE/EQUIP	.00	.00	1,000.00	1,000.00	.0
50-86-741 MACHINERY/EQUIPMENT	.00	.00	5,000.00	5,000.00	.0
50-86-747 COMPUTER SOFTWARE	.00	.00	1,000.00	1,000.00	.0
50-86-748 COMPUTER SUPPORT	1,116.00	1,116.00	4,500.00	3,384.00	24.8
50-86-750 VEHICLES	.00	.00	9,450.00	9,450.00	.0
50-86-760 NEW CONSTRUCTION-SEWER SYSTEM	.00	.00	20,000.00	20,000.00	.0
50-86-775 TAP INSTALLATIONS	.00	.00	3,000.00	3,000.00	.0
50-86-870 INTERFUND TRANSFER	.00	.00	40,000.00	40,000.00	.0
TOTAL SEWER	19,815.78	19,815.78	445,530.17	425,714.39	4.5

TOWN OF THATCHER
 EXPENDITURES WITH COMPARISON TO BUDGET
 FOR THE 1 MONTHS ENDING JULY 31, 2023

SEWER ENTERPRISE FUND

	<u>PERIOD ACTUAL</u>	<u>YTD ACTUAL</u>	<u>BUDGET</u>	<u>UNEXPENDED</u>	<u>PCNT</u>
TOTAL FUND EXPENDITURES	19,815.78	19,815.78	445,530.17	425,714.39	4.5
NET REVENUE OVER EXPENDITURES	<u>16,972.48</u>	<u>16,972.48</u>	<u>4,469.83</u>	<u>(12,502.65)</u>	<u>379.7</u>

TOWN OF THATCHER
BALANCE SHEET
JULY 31, 2023

ELECTRIC ENTERPRISE FUND

ASSETS

55-11900	CASH - COMBINED FUND	4,381,761.66	
55-11999	SOUTHWEST PUBLIC POWER DEPOSIT	442,000.00	
55-13110	ACCOUNTS RECEIVABLE	968,462.92	
55-13130	ACCOUNTS RECEIVABLE CONTRACTS	(.01)	
55-13500	ALLOWANCE FOR BAD DEBT	(169,531.10)	
55-16320	ELECTRICAL SYSTEM	169,094.46	
55-16410	OFFICE FURNITURE & EQUIPMENT	133,755.03	
55-16610	AUTOMOBILE AND TRUCKS	707,011.72	
55-16611	RIGHT OF USE-INTANGIBLE ASSETS	22,202.38	
55-17500	ACCUMULATED DEPRECIATION	(744,957.47)	
55-18000	NET PENSION ASSET	12,945.96	
55-19000	DEFERRED OUTFLOW OF RESOURCES	92,778.54	
	TOTAL ASSETS		6,015,524.09

LIABILITIES AND EQUITY

LIABILITIES

55-20200	WAGES PAYABLE	5,016.48	
55-20210	SALES TAX PAYABLE	122,177.15	
55-21350	CUST. DEPOSITS - ELECTRIC	134,188.71	
55-23500	ACCRUED VACATIONS	72,963.57	
55-25000	NET PENSION LIABILITY	343,854.42	
55-25100	GADA LOAN	199,000.00	
55-25200	LEASES PAYABLE	19,412.10	
	TOTAL LIABILITIES		896,612.43

FUND EQUITY

55-26100	CONTRIBUTED CAPITAL	45,000.00	
55-28000	DEFERRED INFLOWS OF RESOURCES	127,548.13	
	UNAPPROPRIATED FUND BALANCE:		
55-29800	BALANCE - BEGINNING OF YEAR	4,274,284.65	
	REVENUE OVER EXPENDITURES - YTD	672,078.88	
	BALANCE - CURRENT DATE	4,946,363.53	
	TOTAL FUND EQUITY		5,118,911.66
	TOTAL LIABILITIES AND EQUITY		6,015,524.09

TOWN OF THATCHER
REVENUES WITH COMPARISON TO BUDGET
FOR THE 1 MONTHS ENDING JULY 31, 2023

ELECTRIC ENTERPRISE FUND

	PERIOD ACTUAL	YTD ACTUAL	BUDGET	UNEARNED	PCNT
<u>CHARGES FOR SERVICES</u>					
55-33-300 SERVICE FEES - ELECTRIC	741,020.50	741,020.50	6,040,000.00	5,298,979.50	12.3
55-33-310 SERVICE CHARGES - YARD LIGHT	480.26	480.26	6,000.00	5,519.74	8.0
55-33-320 SALES TAX	18,493.12	18,493.12	155,000.00	136,506.88	11.9
55-33-350 CONNECT/RECONNECT FEES-ELECTRC	360.00	360.00	4,000.00	3,640.00	9.0
55-33-400 PENALTY CHARGES	951.93	951.93	16,000.00	15,048.07	6.0
55-33-500 MISCELLANEOUS INCOME	86.75	86.75	50,000.00	49,913.25	.2
55-33-800 OVERAGES/SHORTS	(8.29)	(8.29)	200.00	208.29	(4.2)
TOTAL CHARGES FOR SERVICES	761,384.27	761,384.27	6,271,200.00	5,509,815.73	12.1
<u>INTEREST ON INVESTMENTS</u>					
55-37-100 INTEREST ON INVESTMENT	.00	.00	5,000.00	5,000.00	.0
TOTAL INTEREST ON INVESTMENTS	.00	.00	5,000.00	5,000.00	.0
TOTAL FUND REVENUE	761,384.27	761,384.27	6,276,200.00	5,514,815.73	12.1

TOWN OF THATCHER
EXPENDITURES WITH COMPARISON TO BUDGET
FOR THE 1 MONTHS ENDING JULY 31, 2023

ELECTRIC ENTERPRISE FUND

	PERIOD ACTUAL	YTD ACTUAL	BUDGET	UNEXPENDED	PCNT
<u>ELECTRIC</u>					
55-88-102 SALARIES & WAGES	23,561.80	23,561.80	329,442.14	305,880.34	7.2
55-88-105 OVERTIME	226.30	226.30	2,000.00	1,773.70	11.3
55-88-110 FICA	1,838.91	1,838.91	25,623.07	23,784.16	7.2
55-88-115 RETIREMENT ASRS	2,923.54	2,923.54	40,929.93	38,006.39	7.1
55-88-120 HEALTH	9,256.38	9,256.38	142,500.00	133,243.62	6.5
55-88-127 WORKERS COMP INSURANCE	479.42	479.42	8,500.00	8,020.58	5.6
55-88-150 ASP LABOR	.00	.00	500.00	500.00	.0
55-88-250 EMPLOYEE BONUS	.00	.00	5,500.00	5,500.00	.0
55-88-302 GENERAL INSURANCE	.00	.00	31,000.00	31,000.00	.0
55-88-310 TELEPHONE	218.35	218.35	2,700.00	2,481.65	8.1
55-88-311 CELL PHONES & AIR PLUGS	425.70	425.70	6,200.00	5,774.30	6.9
55-88-325 PROFESSIONAL/TECHNICAL SERVICE	.00	.00	10,000.00	10,000.00	.0
55-88-341 EQUIPMENT MAINTENANCE	.00	.00	5,000.00	5,000.00	.0
55-88-344 PRINTING/ADVERTISING	36.68	36.68	1,500.00	1,463.32	2.5
55-88-347 COMPUTER SOFTWARE SUPPORT	533.23	533.23	22,000.00	21,466.77	2.4
55-88-348 COMPUTER HARDWARE	.00	.00	2,000.00	2,000.00	.0
55-88-349 EQUIPMENT RENTALS	.00	.00	2,000.00	2,000.00	.0
55-88-350 VEHICLE MAINTENANCE	.00	.00	3,000.00	3,000.00	.0
55-88-381 ELECTRICAL SYSTEM WHEELING	22,500.00	22,500.00	1,350,000.00	1,327,500.00	1.7
55-88-385 PURCHASE OF POWER	15,451.94	15,451.94	4,400,000.00	4,384,548.06	.4
55-88-426 ATTORNEY	453.07	453.07	5,000.00	4,546.93	9.1
55-88-505 TRAINING/MEETING/TRAVEL	.00	.00	2,000.00	2,000.00	.0
55-88-510 DUES/SUBSCRIPTIONS	759.00	759.00	12,500.00	11,741.00	6.1
55-88-520 UTILITY BILLS	159.60	159.60	4,100.00	3,940.40	3.9
55-88-525 METER READING	1,828.75	1,828.75	20,500.00	18,671.25	8.9
55-88-533 SMALL TOOLS/HARDWARE	.00	.00	5,000.00	5,000.00	.0
55-88-535 POSTAGE	1,103.91	1,103.91	14,000.00	12,896.09	7.9
55-88-540 OFFICE SUPPLIES	.00	.00	1,500.00	1,500.00	.0
55-88-541 EQUIPMENT SUPPLIES	.00	.00	3,500.00	3,500.00	.0
55-88-542 BLDG MATERIALS/SUPPLIES	.00	.00	3,000.00	3,000.00	.0
55-88-550 VEHICLE SUPPLIES	.00	.00	1,000.00	1,000.00	.0
55-88-553 TIRES/BATTERIES	.00	.00	1,500.00	1,500.00	.0
55-88-555 GAS/OIL/LUBRICANTS	918.38	918.38	14,000.00	13,081.62	6.6
55-88-590 MISCELLANEOUS	.00	.00	2,000.00	2,000.00	.0
55-88-715 SAFETY EQUIPMENT	257.94	257.94	2,000.00	1,742.06	12.9
55-88-740 OFFICE FURNITURE/EQUIP	.00	.00	2,000.00	2,000.00	.0
55-88-741 MACHINERY/EQUIPMENT	.00	.00	5,000.00	5,000.00	.0
55-88-747 COMPUTER SOFTWARE	.00	.00	2,000.00	2,000.00	.0
55-88-748 COMPUTER SUPPORT	1,116.00	1,116.00	7,000.00	5,884.00	15.9
55-88-750 VEHICLES	1,202.04	1,202.04	14,450.00	13,247.96	8.3
55-88-760 NEW CONSTRUCTION-ELEC SYSTEM	.00	.00	40,000.00	40,000.00	.0
55-88-770 POLES	.00	.00	10,000.00	10,000.00	.0
55-88-780 WIRE	.00	.00	2,000.00	2,000.00	.0
55-88-781 STREET LIGHTS	.00	.00	20,000.00	20,000.00	.0
55-88-782 METERS	4,054.45	4,054.45	50,000.00	45,945.55	8.1
55-88-783 TRANSFORMERS	.00	.00	2,500.00	2,500.00	.0
55-88-784 HARDWARE	.00	.00	5,000.00	5,000.00	.0
55-88-850 CONTINGENCY	.00	.00	1,000,000.00	1,000,000.00	.0
55-88-885 DEBT SERVICE	.00	.00	100,000.00	100,000.00	.0
TOTAL ELECTRIC	89,305.39	89,305.39	7,741,945.14	7,652,639.75	1.2

TOWN OF THATCHER
 EXPENDITURES WITH COMPARISON TO BUDGET
 FOR THE 1 MONTHS ENDING JULY 31, 2023

ELECTRIC ENTERPRISE FUND

	PERIOD ACTUAL	YTD ACTUAL	BUDGET	UNEXPENDED	PCNT
TOTAL FUND EXPENDITURES	89,305.39	89,305.39	7,741,945.14	7,652,639.75	1.2
NET REVENUE OVER EXPENDITURES	672,078.88	672,078.88	(1,465,745.14)	(2,137,824.02)	45.9

TOWN OF THATCHER
 BALANCE SHEET
 JULY 31, 2023

FIREMENS PENSION FUND

ASSETS

70-11900	CASH - COMBINED FUND		22,242.96	
			<u>22,242.96</u>	
	TOTAL ASSETS			<u>22,242.96</u>

LIABILITIES AND EQUITY

FUND EQUITY

UNAPPROPRIATED FUND BALANCE:				
70-29800	BALANCE - BEGINNING OF YEAR		11,609.26	
	REVENUE OVER EXPENDITURES - YTD		<u>10,633.70</u>	
	BALANCE - CURRENT DATE		<u>22,242.96</u>	
	TOTAL FUND EQUITY			<u>22,242.96</u>
	TOTAL LIABILITIES AND EQUITY			<u>22,242.96</u>

TOWN OF THATCHER
REVENUES WITH COMPARISON TO BUDGET
FOR THE 1 MONTHS ENDING JULY 31, 2023

FIREMENS PENSION FUND

		<u>PERIOD ACTUAL</u>	<u>YTD ACTUAL</u>	<u>BUDGET</u>	<u>UNEARNED</u>	<u>PCNT</u>
	<u>MISCELLANEOUS</u>					
70-36-100	CONTRIBUTIONS	10,633.70	10,633.70	.00	(10,633.70)	.0
	TOTAL MISCELLANEOUS	<u>10,633.70</u>	<u>10,633.70</u>	<u>.00</u>	<u>(10,633.70)</u>	<u>.0</u>
	TOTAL FUND REVENUE	<u>10,633.70</u>	<u>10,633.70</u>	<u>.00</u>	<u>(10,633.70)</u>	<u>.0</u>
	NET REVENUE OVER EXPENDITURES	<u><u>10,633.70</u></u>	<u><u>10,633.70</u></u>	<u><u>.00</u></u>	<u><u>(10,633.70)</u></u>	<u><u>.0</u></u>

TOWN OF THATCHER
BALANCE SHEET
JULY 31, 2023

GENERAL FIXED ASSETS

ASSETS

90-15200	FLOOD CONTROL	261,812.47
90-15400	SHOP EQUIPMENT	154,625.54
90-15401	RIGHT OF USE-INTANGIBLE ASSETS	34,822.73
90-15600	OFFICE EQUIPMENT	83,441.23
90-15601	RIGHT OF USE-INTANGIBLE ASSETS	65,575.00
90-15800	STREETS & ALLEYS	17,969,527.63
90-16000	STREET EQUIPMENT	1,254,753.02
90-16200	FIRE DEPARTMENT EQUIPMENT	1,835,571.56
90-16400	BUILDINGS/LAND	6,847,075.47
90-16600	POLICE DEPARTMENT EQUIPMENT	888,266.46
90-16601	RIGHT OF USE-INTANGIBLE ASSETS	48,355.86
90-17000	PARKS	2,881,891.06
90-17001	RIGHT OF USE-INTANGIBLE ASSETS	36,694.73
		32,362,412.76
	TOTAL ASSETS	32,362,412.76

LIABILITIES AND EQUITY

FUND EQUITY

UNAPPROPRIATED FUND BALANCE:		
90-29800	BALANCE - BEGINNING OF YEAR	32,362,412.76
	REVENUE OVER EXPENDITURES - YTD	
		32,362,412.76
	BALANCE - CURRENT DATE	32,362,412.76
	TOTAL FUND EQUITY	32,362,412.76
	TOTAL LIABILITIES AND EQUITY	32,362,412.76

TOWN OF THATCHER
BALANCE SHEET
JULY 31, 2023

GENERAL LONG-TERM DEBT

ASSETS

95-18100	FUNDS TO BE PROVIDED	1,255,042.15	
	TOTAL ASSETS		1,255,042.15

LIABILITIES AND EQUITY

LIABILITIES

95-21400	ACCRUED EMPLOYEE BENEFITS	290,438.06	
95-21600	LEASE-GARBAGE TRUCK	168,604.09	
95-25100	BONDS PAYABLE	796,000.00	
	TOTAL LIABILITIES		1,255,042.15
	TOTAL LIABILITIES AND EQUITY		1,255,042.15



June 26, 2023

Josh Bryce, Project Manager
 Graham County Electric Cooperative, Inc.
 9 W. Center St., P.O. Drawer B
 Pima, AZ 85543

Re: Engineering Services Proposal for Reay Lane Substation Project

Dear Mr. Bryce:

Transmission & Distribution Services LLC (T&D) respectfully submits this proposal dated June 26, 2023 (Proposal) to Graham County Electric Cooperative (GCEC) for Professional Engineering Services for its Reay Lane Substation Project (Project).

The Project includes the design and engineering services for a new 12/16/20 MVA, 69/12.47 kV distribution substation to replace the existing New Thatcher Substation. The Project has an anticipated design completion date of year end 2023. T&D’s anticipated scope of work and deliverables are described in the GCEC provided Scope Document and Project Management Plan for the Project dated June 1st, 2023. T&D takes no exception to the deliverables list and scope details and acknowledges that GCEC will predominantly lead the effort on material and labor bids for the Project as well as coordination with the wholesale utility provider, Arizona Electric Power Cooperative (AEPSCO). T&D’s lead engineering staff assigned to the Project were both involved with the Talley Substation design and will incorporate their knowledge and experience gained with that project to this Project.

T&D’s compensation for the Project will be invoiced monthly on a time and expense basis per the rates listed below with a not to exceed cost as noted. Hours listed are estimates and totals will vary depending on actual labor effort utilized but will not exceed the total cost as noted.:

<u>Title</u>	<u>Rate/Hr</u>	<u>Estimated Hours</u>	<u>Extended Cost</u>
Principal Engineer	\$ 225	330	\$ 74,250
Senior Engineer	\$ 205	365	\$ 74,825
Graduate Engineer	\$ 155	130	\$ 20,150
CAD Designer	\$ 120	240	\$ 28,800
Surveying Support	\$ 145	80	\$ 11,600
Admin	\$ 80	40	\$ 3,200
		~1185	\$ 212,825
Mileage (at IRS rates)			~\$ 2,000
Equipment/Reproduction/Postage			~\$ 1,850
Meals/Motels or Per Diems			~\$ 3,000
<i>(up to three (3) site visits: (1) kickoff and (2) for surveying)</i>			\$ 6,850
			\$ 219,675 NTE

P&C Scope:

The proposed Reay Lane Substation will have a Protection and Control (P&C) system similar to the Talley Substation which will align with AEPCO standards for protection and SCADA. Transformer primary protection will consist of a SEL-387 differential relay while the 15kV bus primary protection will be comprised of a SEL-487B relay. Transformer and 15kV bus backup overcurrent protection will utilize SEL-351S relays. The 15kV feeder protection includes SEL-651S relays to be located on the recloser stands in the yard. The station annunciator will be a SEL-2523 or similar type device.

Breaker/recloser control will be via pistol grip style control handles located inside the control building. Each control switch will be capable of SCADA control as well with a typical 'Push/Pull' feature that can Enable/Disable SCADA similar to the type employed at other GCEC stations.

Metering for the 15kV bus will include both a panel meter and redundant kWh meters with one kWh meter for GCEC and one for AEPCO. The panel meter will serve for local and SCADA indication while the kWh meter will serve for billing and record keeping. The 15kV feeder metering will be a single panel/SCADA meter and a single kWh meter. T&D will work with both GCEC and AEPCO on preferred metering types and unique application details.

The SCADA system will be included in the design and will be based on AEPCO input and design requirements. The anticipated communication path will be an AEPCO prescribed radio transceiver, similar to the existing Talley Substation.

Aside from the 15kV recloser relays, all other protection and control equipment will be mounted in free standing panels located inside the control building. The protection and control system will be powered by the station's 125V DC battery system.

T&D anticipates preparing complete relay, metering and control panel drawings for the Project, including detailed wiring diagrams and construction details, to ensure GCEC understands exactly what it will receive in the fabricated product. We believe that this approach is of greater value to our clients as compared to simply preparing a one-line diagram from which a panel manufacturer will develop a drawing package. While the up-front engineering design costs may be less when having a panel manufacturer prepare the drawings, the final product is typically far less desirable both in terms of initial installation and future additions/modifications.

P&C Assumptions and Exclusions:

1. 69kV line protection anticipated to be step distance and backup overcurrent. Line differential design is excluded from the design package.
2. AEPCO to provide standards, details and documentation for preferred protection system and for the SCADA system connection points. T&D's SCADA design scope is limited to remote control of the high side breaker similar to the Talley Substation. Additional SCADA/RTU design/detailing is excluded.
3. Fiber optic communications channel design to GCEC headquarters and/or AEPCO operations is excluded.

Station Scope:

The proposed new station will be as outlined in the scope document provided by GCEC and will incorporate the Owner-furnished equipment as listed. T&D is the Engineer of Record for the Talley Substation completed in 2013. As the Talley Substation is listed as the 'go-by' for use in the Reay Lane Station Design, T&D will use our knowledge of the Talley Substation details to achieve a best value design option for GCEC both in terms of cost and design timeline.

The horizontal main and transfer type bus configuration will be designed similar to the Talley Substation and will be comprised of similar steel structures, components and layout.

GCEC has always been ahead of the game when it comes to provision of equipment for its substation projects including station transformers, reclosers, breakers and regulators. T&D takes no exception to the incorporation of the Owner-furnished equipment listed in the Project scope of work. The control building is anticipated to be either metal construction or pre-cast concrete pending GCEC's preference with either a pier or slab-on-grade foundation, as required by the vendor selected. T&D will prepare conceptual drawings and specifications for this item to be used to solicit bids from vendors and work with the selected vendor on submittals as needed.

Similar to the relaying, metering and control design package, T&D will prepare a complete steel and foundation design package, including steel fabrication drawings, material lists and fastener details as well as complete reinforcement and anchor bolt design. Design analysis details, based on the information provided in the geotechnical study recommendations, are included in our Proposal for foundation and steel packages.

Station grounding and lightning shielding design analysis are also included in our design Proposal. This design will be prepared using the University of Georgia's WinIGS software package. Both the grounding design and the lightning shielding details will be similar to that found at the Tally Substation including exothermic connections and static masts with spline ball type lightning eliminators. Station deadend connections will also utilize shield wire connections.

Stations Assumptions and Exclusions:

1. The proposed Project design criteria and basis of design will be in accordance with previous GCEC station projects and tailored for the unique Project location. T&D's designs are based on established IEEE/RUS and NESC design methodologies, recommendations and rules, as well as client supplemental engineering preferences, as may be applicable such as station specific signage or labelling.
2. T&D's electrical design package is prepared based on an AutoCAD 3D model of the proposed station. This model can then be utilized to prepare elevations, sections, details, and material lists. The design packages will be straightforward and clear, similar to other GCEC projects. A full station bill of materials is included in our design package with individual item callouts to connect the material list to the drawings.

3. Beyond the detailed drawing package that illustrates the station design, a robust construction specification package is included in our design package offering. The specifications will address perimeter fence installation, erection, concrete, relay/meter/control panels and materials as applicable.
4. Distribution bus design to include horizontal, main and transfer bus using standard shape steel members or I-beam designs, similar to the Talley Substation design package. Complete structure drawings/erection drawings and details are included in our offering.
5. Geotechnical boring and site resistivity testing costs are excluded from T&D's proposal. T&D is willing to prepare a specification and solicit bids for these services to provide a recommendation to GCEC. GCEC to coordinate with the Geotechnical firm to schedule and conduct all site activities. Note that the timing of design submittals, including foundation and grounding details, is based on information from these studies. Delays in providing this data could impact timing of deliverables.
6. Foundation design is limited to simple drilled piers, slabs on grade with over-excavation or cast-in-place concrete designs. Retaining walls, concrete reinforced diversion features such as the one at Talley Substation, and/or specialized foundations necessitated due to poor soil conditions are excluded and may become a change order should they be required.
7. Station major material bidding is anticipated to be a joint effort between GCEC and T&D. Items such as the control building, relay panels, structural steel and other long lead time equipment such as switches, insulators, etc. can be solicited based on a mutually agreed upon list prepared in conjunction with GCEC's schedule and procurement desires. T&D maintains a list of qualified bidders for these items and we can prepare a recommendation to GCEC for procurement. Items can be solicited by GCEC or by T&D based on a part number specified or equipment specifications. T&D will provide and/or review bids received by GCEC but will not be responsible for solicitation of the bids from vendors or distributors unless asked to do so. T&D excludes any purchase/procurement of materials for the Project.
8. Station construction labor bidding/procurement, construction review and related commissioning/testing services will be conducted by GCEC with limited oversight by T&D.
9. GCEC has indicated that no commissioning services are required for the design scope of the Project. In addition to providing relay/meter data files for GCEC to use in meter and relay programming, T&D offers limited remote support for Project commissioning.
10. Site surveying is limited to two visits. The first is to collect a site topographical survey of the GCEC property and surrounding station area. The second is to establish Project survey control monuments such as baselines, benchmark elevations, and fence corners. Construction surveying is excluded.
11. Site civil designs including grading/drainage drawings and details are included in the proposed design package. As the site is well established, it is anticipated that significant drainage improvements will not be required. Lime stabilization of the aggregate base (4") for the station

area, including three feet beyond the disturbed area, will be included in the design details as stipulated. Environmental, archaeological, biological reviews/permits, or any related documentation for the Project are excluded.

12. T&D anticipates 50%/90%/IFC Project submittal packages with electronic reviews for each. Client comments will be addressed for each review. A site visit is included for the Project design kickoff meeting. As this Proposal is for design services only, we have not included construction related site visits but are willing to provide these services at our standard rates.
13. 69kV transmission line design for the proposed station is limited to the description provided in the GCEC scope section. Design details for the two new 69kV switch poles and the tapped span of conductor into the new station will be included in our package.
14. Distribution line/underground feeder design is limited to the three (3) underground feeders which will be prepared in a similar fashion to the Talley Substation and as described in the current Project scope. Drawings/details for risers located outside of the station fence are excluded.
15. Demolition drawings/details requirements for the existing station were not addressed in the Project scope document and are excluded from T&D's Proposal.
16. While T&D anticipates the need to interface with AEPCO to review Project details, we anticipate interaction to be limited. Should extended meetings be required to coordinate efforts, a change order may become necessary to cover the additional costs.

Proposed Schedule:

Given a notice to proceed of August 1st, and pending availability of geotechnical information for the site, T&D anticipates the following submittal schedule. Note that this conceptual schedule is subject to modification if needed to facilitate GCEC requirements or board meeting deadlines.

50% Submittal	September 5
90% Submittal	October 3
IFC Submittal	November 7

Thank you for the opportunity to present this Proposal. If this Proposal is acceptable, please provide T&D with a Purchase Order as our Notice to Proceed or if you have any questions, please contact me at (505-803-5032/kadams@t-d-services.com). We look forward to extending our working relationship with GCEC and can immediately commence work on the initial design package upon Notice to Proceed.

Sincerely,

Kenneth Adams

Kenny Adams, P.E.
Director of Station Engineering



3940 GLENBROOK DRIVE HAILEY, ID 83333 | 208-788-3456
WWW.POWERENG.COM

July 12, 2023

Joshua Bryce
Graham County Electric Cooperative, Inc.
9 W Center St.
Pima, AZ 85543

Subject: Thatcher Substation Design

Dear Josh:

POWER Engineers (POWER) is pleased to provide a proposal to provide engineering services for Graham County Electric Cooperative's (GCEC) Thatcher Substation project. Our work plan, schedule, and budget follow this letter.

Our Power Delivery substation capabilities include new substation design, modifications, additions, and upgrades, site work and access roads, protective relaying, SCADA systems, communication systems, automation systems, and IEC 61850 migration. Optional supporting services include field assessments, staking, permitting, easement support, estimating, and construction support.

Ultimately, by partnering with POWER, GCEC will receive the following benefits:

- » **Experience with Electric Cooperatives.** Since POWER's founding in 1976, we have been dedicated to meeting the engineering needs of electric cooperatives. Many of our early clients were cooperatives, and more importantly, they are still our clients today. This dedication reflects our corporate philosophy. From our president and department leaders to our design staff, we are committed to providing quality services at a competitive price for electric cooperatives.
- » **Responsive, Regional Presence.** GCEC can count on our seamless communication and efficient procedures. We will support this project out of our Phoenix office, which allows us to address all planned and unplanned project tasks in a timely manner.
- » **Technical Expertise.** Our team of experts will provide flexible options for creative, high-quality, innovative solutions to complete your project resourcefully and correctly.

We appreciate your consideration and look forward to discussing our proposal with you. Please reach out with any questions or comments.

Sincerely,

A handwritten signature in black ink that reads "Mike Walbert". The signature is written in a cursive, flowing style.

Mike Walbert, P.E.

Senior Project Manager

Proposed Schedule

POWER Engineers proposes the following tentative milestone schedule based on the tasks and deliverables described in the Work Plan.

The proposed schedule assumes that the project award notification would arrive on 7/17/2023.

69/12.47 kV Thatcher Substation

Function	Deliverable	Type	Due Date
Notice	Project Award		7/17/2023
Contract/Purchase Order	Fully Executed Purchase Order Received		7/24/2023
Preliminary Design	Project Start-Up Meeting	Conference Call	7/24/2023
Site Visit if Required		Site Visit	Week of 08/01
Civil and Studies	Review Geotechnical Spec	Submittal	8/14/2023
Civil and Studies	Receive Geotechnical Report		9/11/2023
Civil - Site	Substation Drawings 30% Review Submittal	Submittal	11/20/2023
Civil - Site	Substation Civil Site 60% Submittal	Submittal	3/18/2024
Civil - Site	Substation Drawings IFC Submittal	Submittal	4/15/2024
Civil - Structural Steel	Substation Drawings 30% Review Submittal	Submittal	10/16/2023
Civil - Structural Steel	Substation Steel Drawings & Fabrication Spec 60% Submittal	Submittal	12/11/2023
Civil - Structural Steel	Substation Steel Drawings & Fabrication Spec 90% Submittal	Submittal	1/15/2024
Civil - Structural Steel	Substation Steel Drawings IFF Submittal	Submittal	1/15/2024
Civil - Below Grade	Substation Drawings 30% Review Submittal	Submittal	9/25/2023
Civil - Below Grade	Substation Civil Foundations & Calculations 60% Submittal	Submittal	11/6/2023
Civil - Below Grade	Substation Civil Foundations & Calculations 90% Submittal	Submittal	12/11/2023

Civil - Below Grade	Substation Drawings IFC Submittal	Submittal	1/15/2024
Electrical - Above Grade	Substation Drawings 30% Review Submittal (GA and CH)	Submittal	8/28/2023
Electrical - Above Grade	Substation Drawings 60% Review Submittal (Elevations)	Submittal	11/20/2023
Electrical - Above Grade	Substation Drawings 90% Review Submittal (Details)	Submittal	3/18/2024
Electrical - Above Grade	Substation Drawings IFC Submittal (BOM)	Submittal	4/15/2024
Electrical - Below Grade	Substation Drawings 30% Review Submittal	Submittal	8/28/2023
Electrical - Below Grade	Substation Drawings 60% Review Submittal	Submittal	11/20/2023
Electrical - Below Grade	Substation Drawings 90% Review Submittal (calcs)	Submittal	3/18/2024
Electrical - Below Grade	Substation Drawings IFC Submittal (BOM)	Submittal	4/15/2024
Electrical - P&C	Substation Drawings 30% Review Submittal (One-Line)	Submittal	8/28/2023
Electrical - P&C	Substation Drawings 60% Review Submittal	Submittal	11/20/2023
Electrical - P&C	Substation Drawings 90% Review Submittal	Submittal	3/18/2024
Electrical - P&C	Substation Drawings IFC Submittal	Submittal	4/15/2024
Panel Design	Panel Design - 90% Submittal	Submittal	3/18/2024
Panel Design	Panel Design - IFC (internal wiring)	Submittal	4/15/2024
Grounding Study	Grounding - IFR	Submittal	11/20/2023
Grounding Study	Grounding - IFC	Submittal	3/18/2024
Relay Settings	Relay Settings - IFR	Submittal	4/8/2024
Relay Settings	Relay Settings - IFC	Submittal	4/22/2024

Budget

POWER developed the proposed budget based on our understanding of this project’s scope of work and our experience with similar projects. The tasks listed below correspond to the tasks described in our proposed work plan. The table summarizes the budget for services to be provided on a Time and Materials NTE basis for **\$297,062**.

Budget Summary by Task

	Task Description	Hours	Labor \$	Exp \$	Total \$
0	Project Management	136	\$23,328	\$2,933	\$26,261
1	Substation Initiation	111	\$16,599	\$235	\$16,834
2	Major Equipment Specifications	28	\$4,344	\$0	\$4,344
3	Physical Design	310	\$42,314	\$0	\$42,314
4	Civil/Structural Design	422	\$57,390	\$0	\$57,390
5	Control & Relaying Schematics	227	\$28,477	\$0	\$28,477
6	Wiring Diagrams	305	\$36,057	\$0	\$36,057
7	Protective Relay Settings and Grounding Analysis	275	\$44,635	\$400	\$45,035
8	Control Shelter	93	\$12,457	\$0	\$12,457
9	Pre-Construction Activities	14	\$2,068	\$0	\$2,068
10	Construction Activities	122	\$18,260	\$185	\$18,445
11	Construction Management (Task Not Used)	0	\$0	\$0	\$0
12	Post-Construction Activities	66	\$7,380	\$0	\$7,380
	Project Total	2,109	\$293,309	\$3,753	\$297,062

Houston, July 20th, 2023**Graham County Electric Cooperative.****Attn.:** Mr. Joshua Bryce / Project Manager**Reference Project/RFP:** Transformer Bid for the Graham County Electric Cooperative
69 kV Delta - 12.47/7.2 kV Gnd-Y, 12/16/20//22,5 MVA,
Power Transformer – Reay Lane Substation, Thatcher, AZ.

Dear Madam/Sir,

We are pleased to submit our proposal for the referenced material requisition. There are no technical deviations from your Spec GCECGENTR (rev. 052023).

Additionally, we would like to highlight our USA services capabilities:

- Commercial office in Houston for project management and after sales support (available 24/7).
- Factory certified field services engineer to supervise units' assembly.
- Field assemblies: we partner with established, HV specialized services providers for site dressing. Our regular services partners are OTC Services, StarkOil Int'l and NASS. We have flexibility to engage with other services providers as required either by geographic location or customer's preferences.
- Repairs: TTE (our sister company manufacturing PTs) has an industrial and technical cooperation agreement with SGB-SMIT Group (leading European manufacturer of power Transformers) including but not limited to service support for the USA Market. In the event of any factory repair is required, we will hire OTC repair services (a SGB subsidiary) Any repair will be conducted with our onsite supervision.
- Technical Support: we are committed to high response time for any urgent technical services: (i) Field Response within (24) hours for "Emergency on-site interventions"; (ii) Incoming Inspections, including un-taking, within (2) weeks of receipt of the unit at the repair location.

We are including in our commercial proposal the following information:

- **Complete itemized price sheet and sales conditions.**
- **Commercial Exemptions to Warranty.**
- **Addendum "A" – Product Limited Warranty**
- **Schedule A** – Technical Offer supporting Data, including transformer's accessories list, outline drawing and main components' technical information.
- **Schedule B** – Company's background information, including company's brief, supply record to North American markets, customer reference list and Failures record (as per ANSI/IEEE C57.117 Guide).

D O



Our Ref.: [RFP 230467]

We thank you for your consideration and the opportunity to be considered as a potential supplier for this project. We and our engineering team remain fully available for any further enquiry or clarification you may have. We look forward to hearing from you soon.

Best Regards.

Pralar USA, Inc

By 

Diego E. Olmos

Vice President North America

dolmos@pralar.com
(832) 423-3955

ITEMIZED PRICE SHEET

ITEM #	QTY	DESCRIPTION	UNIT PRICE (U\$S)
1.1	2	Power transformer , 3 phase, 12/16/20/22,5 MVA at 55/65°C – 69/12.47 kV, 60 Hz, with de-energized tap changer in HV side, group connection Dyn1, and all according to GCEC Specifications.	518,950.00
1.2	1	Freight up to destination and offloading onto the pad (including applicable port and import taxes).	99,800.00
1.3	1	Field services. Complete transformer assembly, oil delivery, vacuum oil processing and field testing at the substation, including factory certified serviceman supervision, for a maximum of 7 days at jobsite to complete all tasks.	73,670.00
TOTAL PRICE			692,420.00
2	1	SUGGESTED SPARE PARTS: <ul style="list-style-type: none"> • 1 (one) HV Bushing • 1 (one) LV Bushing • 1 (one) Set of Gaskets 	6,900.00 4,100.00 800.00

NOTE 1: Pricing for items 1.2 and 1.3 are based on estimates at the time of proposal. Prices could be adjusted at the time of delivering the goods, in the event of total contracted logistic fares have a variation of more than 5% (plus or minus) vs quoted.

NOTE 2: Prices exclude applicable sales and use taxes.

D O

WESTERN UNITED ELECTRIC SUPPLY
Substation Power Transformer

Proposal #: O232301A | 22 June 2023

Customer Contact Information

Substation Power Transformer
WESTERN UNITED ELECTRIC SUPPLY
Frank Torres
100 BROMLEY BUSINESS PKWY
BRIGHTON, CO 80603
505-346-9573
ftorres@wue.coop

VTC Contact Information

PPU SOUTH
540-581-2825
Jesse_Hall2@vatransformer.com
220 Glade View Drive, NE Roanoke,
24012
Phone:540-345-9892 Fax:540-342-7694
www.vatransformer.com

Virginia Transformer Corporation

This document contains Virginia Transformer Corp proprietary information and may not be copied or disclosed to others without written consent from Virginia Transformer Corp.

For over 50 years, innovative technology and a commitment to superior customer service and support has established Virginia Transformer Corp(VTC) as an engineering company leading in manufacturing a variety of transformers.

VTC designs and manufactures custom power transformers ranging from 500 KVA to 400 MVA, 500 kV class (core type) and up to 1400 MVA, 500 kV class (shell type), and dry-type units up to 15000 KVA, 35 kV.

VTC has design and manufacturing facilities in Roanoke, VA, Pocatello, ID, Chihuahua, Mexico and Georgia Transformer in Rincon GA. In addition, VTC has design and procurement capabilities in Delhi, India, establishing a world-wide presence as a supplier of transformer solutions. VTC reserves the right to manufacture the product quoted herein at VTC owned or affiliated plants in North America.



ISO 9001

"The Commitment Company"

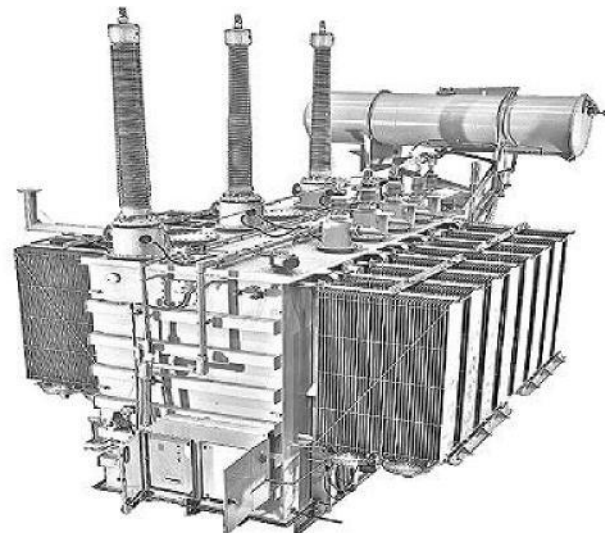

Substation Power Transformer
WESTERN UNITED ELECTRIC SUPPLY

Proposal #: 0232301A



Commercial Summary

Base Price

Item	Description	Qty	Unit Price (USD)	Extended Price (USD)
1	12,000 / 13,440 / 16,000 / kVA 69 - 12.47 kV	17,920 / 20,000 / 22,500	\$925,336.00	\$925,336.00

Tax Certificates Requirement

Upon acceptance of our proposal, the purchaser is required to submit a sales tax exemption certificate with the Purchase order, otherwise VTC will charge appropriate state taxes based on the destination.

Price Policy

In the event of customer delay on a job quoted with a firm price and shipment date, VTC/GTC will apply the BLS Transformer Index to adjust price. The agreed firm price will be escalated with the base period being the quoted shipment date and the Settlement date being the month of shipment. Only increases in the BLS index will be considered for this calculation. Any advance payments will be credited to the final invoice. No adjustment will be applied if the transformer is completed and shipped prior to the quoted shipment date.

Validity of Quote

07/15/2023

Estimated Freight Cost

Item	Ship to	Qty	Freight Cost (USD)	Extended Freight Cost (USD)
1	THATCHER, AZ	1	\$18,500	\$18,500

VTC will quote freight at the time of shipment.

Substation Power Transformer
WESTERN UNITED ELECTRIC SUPPLY

Proposal #: 0232301A



ITEM #1

Optional Pricing

Particulars	Price (USD/Per Unit)
Additional Day Onsite Training with VTC Personnel	\$11,000

For Witness testing, cost for travel, transportation, lodging and meals are not included in the quoted price unless otherwise noted.

Shipping

Unit Shipment By	50-55 Weeks from Order Acknowledgement date.VTC reserves the right to ship unit up to 3 months earlier than the contractual ship date.
Freight	PREPAID & ADD
Estimated Freight Cost (Per Unit)	\$18,500
INCO Terms	FOB - FREE ON BOARD(Delivery from Roanoke, VA to Thatcher, AZ)
Proposed Manufacturing Location	ROANOKE, VA USA
Impact Recorder	Impact Recorder to be provided on Returnable Basis, \$ 7,500 to be invoiced if not returned in 30 days after Delivery.

VTC cannot guarantee multiple units to arrive at the same time unless more than one unit can be loaded on the same truck. VTC cannot guarantee arrival dates and times at the job site. Final Lead time will be confirmed at the time of order acknowledgements

Proposed Payment Terms

30% Advance with Purchase Order
30% upon drawing submittal, net 30 days
40% invoiced at the time of Shipment or upon moving to storage, Net 30 days

Field Service

Field Service Training	Included
Unloading	Included
Assembly	Included
Field Service Testing	Included



Proposal



Simple...

WEG WILL

- Make it easy to do business
- Handle complex specifications
- Manage the complete project
- Provide short cycle deliveries
- Manufacture the most reliable transformer
- Provide support during the entire life of your transformer



June 28th, 2023

To: Graham county Electric Cooperative

CC: SourceWest

SUB: 1 x 22.5 MVA 69/12.47 kV Power transformer with DETC
YOUR REF: GCECGENTR
OUR REF: WTM23-409

Dear Sir or Madam,

With reference to the above mentioned inquiry, we are pleased to present our detailed commercial and technical proposal and confirm that our proposal is based on the requirements specified by the above mentioned RFP.

Our proposal consists in the following sections:

- A- Price sheets
- B- Project Specific T&Cs
- C- ANSI and Outline Drawings
- D- Comments/Deviations on Specifications
- E- Standard T&C's
- F- Additional Information

Please refer to sections B and D for additional information and assumptions made regarding this offer.

We hope you will find our offer in line with your requirements. If you have any questions or need additional information or clarification please do not hesitate to contact our representative (see details under cc:) or us directly (Katie Goodale) at tel.: (636) 239-9352, fax: (636) 239-9398, E-mail: kgoodale@weg.net.

Thank you and assuring you of our best services. Sincerely yours,

WEG Transformers USA

A handwritten signature in cursive script that reads "Katie Goodale".

Katie Goodale
Quotation Engineer
Tel.: (636) 239-9352
Fax: (636) 239-9398
E-Mail: kgoodale@weg.net

Alex Crews
Product & Sales Manager
Tel.: (636) 239-9340
Fax: (636) 239-9398
E-Mail: acrews@weg.net

You are requested to please refer to our Customer and Supplier Privacy Policy available on our website to understand and familiarize yourself with our Privacy Policy towards its business partners with respect to sharing of personal data.

STANDARD PRICING OF EQUIPMENT

All below prices are in USD

No Taxes or Import Tarrifs are included in these prices.

Item	Description	Qty.	Unit Price	Total Price
1	12/16/20///22.5 MVA, 55/65C rise – 69/12.47 kV,Delta-Wye two winding 60 Hz, ZH-X=8.1% (12 MVA base) with HV DETC along with accessories.	1	1,130,328	1,130,328
	Freight for item 1		37,400	37,400
	Offloading for item 1		12,650	12,650
	Service for item 1		24,500	24,500
	Total for item 1		1,204,878	1,204,878

We hope you will find our offer in line with your requirements. Should you require any further information, please feel free to contact us.

Katie Goodale
Quotation Engineer
T: +1 636 239 9352
kgoodale@weg.net

Alex Crews
Sales & Marketing Manager WTU
T: +1 636 239 9340
acrews@weg.net

PRICES FOR OPTIONAL EQUIPMENT

All below prices are in USD

Item	Description	Unit	Qty.	Unit Price	Total Price
SPARE PARTS FOR LINEITEMS 1.					
1	High Voltage Phase Bushing with gasket	pcs	1	9,600	9,600
2	Low Voltage Phase Bushing with gasket	pcs	1	5,400	5,400
3	Set of gaskets	set	1	3,000	3,000
4	High Voltage Arrester	pcs	1	3,000	3,000
5	Low Voltage Arrester	pcs	1	1,800	1,800
	Total for spares				22,800
OPTIONS FOR LINEITEMS 1.					
1	Shock Recorder (if not returned)	pcs	1	2,500	2,500

We hope you will find our offer in line with your requirements. Should you require any further information, please feel free to contact us.

Town of Thatcher
 Project No. 23-24-04
SEWER CLEANING & CCTV
Bid Schedule

Item No.	Pay Item	Estimated Quantity	Unit	Cost	
				Unit \$	Line Item \$
1	Mobilization	1	lump sum	\$500.00	\$500.00
2	Traffic Control	1	lump sum	\$500.00	\$500.00
3	Sewer Clean & CCTV (8" - 12")	40,692	linear feet	\$1.50	\$61,038.00

Total Bid Amount:

\$62,038.00

Name: Kyle Adame	Company Name: BCAC Underground
Signature: 	Date: 8-16-23

PROPOSED CHANGES FOR
SCHEDULE OF FEES AND CHARGES

ADMINISTRATION

	<u>CURRENT</u>	<u>PROPOSED CHANGE</u>
PAPER COPIES	.10 cents per page	.20 cents per page
FAX TRANSMISSION/RECEIVE	.10 cents per page	.20 cents per page
NOTARY SERVICES	Free of charge	\$5.00 (Free of charge for Thatcher residents)
PUBLIC RECORDS REQUEST	Not listed	\$5.00 for the first 10 pages, .10 cents per each additional page

POLICE DEPARTMENT

	<u>CURRENT</u>	<u>PROPOSED CHANGE</u>
POLICE REPORTS	\$5.00	\$5.00 for the first 10 pages, .10 cents per each additional page
FINGERPRINTING	Free of charge	\$10 (Free of charge for Thatcher residents)
VIDEO RECORDINGS	Not listed	\$25.00 for first 30 minutes and \$25.00 each 30 minutes thereafter, this fee will be in addition to the delivery method fee of email
PUBLIC RECORDS REQUEST	Not listed	\$9.00, flash drive \$20.00
EMAIL OF RECORDS	Not listed	\$5.00 for the first 10 pages, .10 cents per each additional page
FLASH DRIVE WITH RECORDS	Not listed	\$9.00 (5 MB limit)
VEHICLE IMPOUND FEE	\$10.00	\$20.00 (16 GB limit)
		\$15.00 per day plus tow fees

PLANNING AND ZONING

	<u>CURRENT</u>	<u>PROPOSED CHANGE</u>
SUBDIVISION PELIMINARY PLAT		
0 – 100 lots	\$300.00 plus \$2.00 per lot	\$300.00 plus \$10.00 per lot
101 Lots and Over	\$300.00 plus \$2.00 per lot	\$300.00 plus \$10.00 per lot
SUBDIVISION FINAL PLAT	\$3.00 per lot with a minimum charge of \$100.00	\$300.00 plus \$25.00 per lot
PLANNING & ZONING ORDINANCE	\$15.00 per copy	\$25.00 per copy (available online)

ELECTRIC

	<u>CURRENT</u>	<u>PROPOSED CHANGE</u>
DEPOSIT FEES FOR NEW SERVICE	\$80.00 per residential	\$100.00 per residential service



SCHEDULE OF FEES AND CHARGES

Updated 8/2023

The Thatcher Town Council has adopted the following fees and charges, which will be reviewed periodically and adjusted by resolution as needed for inflation, cost increases or decreases. These fees (one-time cost items) and charges (ongoing cost items) show the public what the Town of Thatcher intends to require for use of equipment, personnel, services, and commodities, which the Town provides to the citizens of Thatcher.

ACCEPTED FORMS OF PAYMENT INCLUDE CASH, CHECKS, DEBIT/CREDIT CARDS (fees will apply). Debit/Credit cards are accepted by phone.

ADMINISTRATION

PAPER COPIES	.20 cents per page
FAX TRANSMISSION / RECEIVE	.20 cents per page
NOTARY SERVICES	\$5.00 (Free of charge for Thatcher residents)
NON-SUFFICIENT CHECK FUNDS (NSF)	\$25.00
PUBLIC RECORDS REQUEST	\$5.00 for the first 10 pages, .10 cents per each additional page
BUSINESS LICENSE	\$40.00 per calendar year
HOME OCCUPATION BUSINESS LICENSE	\$40.00 per calendar year
PEDDLER'S BUSINESS LICENSE	\$30.00 per calendar year

RECREATION

LITTLE LEAGUE BASKETBALL	\$50.00 per participant (residents only)
LITTLE HOOPSTERS	\$50.00 per participant (residents only)
LITTLE LEAGUE VOLLEYBALL	\$50.00 per participant (residents only)
LITTLE LEAGUE WRESTLING	\$50.00 per participant (residents only)
SUMMER BASEBALL/SOFTBALL LEAGUE	\$50.00 per participant \$75.00 per out-of-town participant
SWIM TEAM	\$50.00 per participant \$75.00 per out-of-town participant
WOMEN'S VOLLEYBALL LEAGUE	\$300.00 per team
MEN'S BASKETBALL LEAGUE	\$450.00 per team

POLICE DEPARTMENT

POLICE REPORTS	\$5.00 for the first 10 pages, .10 cents per each additional page
FINGERPRINTING	\$10.00 (Free of charge for Thatcher residents)
LETTER OF CLEARANCES	No charge
SUBPOENAS	\$25.00
VIDEO RECORDINGS	\$25.00 for first 30 minutes and \$25.00 each 30 minutes thereafter, this fee will be in addition to the delivery method fee of email \$9.00, flash drive \$20.00 <i>Fee is pursuant to ARS 41-1734</i>
PUBLIC RECORDS REQUEST	\$5.00 for the first 10 pages, .10 cents per each additional page
EMAIL OF RECORDS	\$9.00 (5 MB limit)
FLASH DRIVE WITH RECORDS	\$20.00 (16 GB limit)
DOG LICENSES	\$2.00 or \$5.00 if not spayed/neutered
VEHICLE IMPOUND FEE	\$15.00 per day plus tow fees

CEMETERY

SPACE (7' x 4')	\$400.00
CURBING AROUND LOTS	\$13.50 per linear foot

PLANNING AND ZONING

APPEAL TO BOARD OF ADJUSTMENT	\$200.00
APPLICATION FOR VARIANCE	\$200.00
ADMINISTRATIVE PERMITS	\$50.00
CONDITIONAL USE PERMIT	\$200.00
REVERSION TO ACREAGE OR ABANDONMENT	\$300.00
RE-ZONING REQUEST	\$200.00
TEMPORARY USE PERMIT	\$200.00
SUBDIVISION PELIMINARY PLAT	
0 – 100 Lots	\$300.00 plus \$10.00 per lot
101 Lots and Over	\$300.00 plus \$10.00 per lot
SUBDIVISION FINAL PLAT	\$300.00 plus \$25.00 per lot
RECORDING FINAL PLAT	\$50.00 per sheet
AMENDED FINAL PLAT	\$50.00 per sheet
PLANNING & ZONING ORDINANCE	\$25.00 per copy (available online)

BUILDING PERMIT FEES	
Mobile Home Setup	\$100.00
Construction	Fee based on percentage of overall value
TOTAL VALUATION	FEE
\$1.00 – \$500.00	\$20.00
\$501.00 to \$2,000.00	\$20.00 for the first \$500.00 plus \$1.00 for each additional \$100.00 or fraction thereof, to and including \$2,000.00
\$2,001.00 to \$25,000.00	\$35.00 for the first \$2,000.00 plus \$6.00 for each additional \$1,000.00 or fraction thereof, to and including \$25,000.00
\$25,001.00 to \$50,000.00	\$200.00 for the first \$25,000.00 plus \$5.00 for each additional \$1,000.00 or fraction thereof, to and including \$50,000.00
\$50,001.00 to \$100,000.00	\$325.00 for the first \$50,000.00 plus \$3.00 for each additional \$1,000.00 or fraction thereof, to and including \$100,000.00
\$100,001.00 to \$500,000.00	\$475.00 for the first \$100,000.00 plus \$2.50 for each additional \$1,000.00 or fraction thereof, to and including \$500,000.00
\$500,001 and up	\$1,475.00 for the first \$500,000.00 plus \$1.50 for each additional \$1,000.00 or fraction thereof

SANITATION

GARBAGE AND REFUSE PICKUP	\$16.00 per month for 90-gallon container \$43.00 per month for 300-gallon container
REMOVAL OF DEAD LARGE ANIMAL	\$25.00
ANY LOAD REQUIRING A LOADER	\$25.00 per load
APPLIANCES	Landfill charges will apply
LOADS TAKEN TO LANDFILL	Landfill charges will apply
<i>HAZARDOUS WASTE OR MATERIAL IS NOT ACCEPTED BY THE LANDFILL AND WILL NOT BE PICKED UP BY THE TOWN. PLEASE REFER TO OUR REFUSE POLICY FOR SPECIFICS ON APPLIANCES AND LOADS TAKEN TO LANDFILL.</i>	

SEWER

RESIDENTIAL	\$15.00
APARTMENTS	\$15.00 per apartment
RETAIL – WHOLESALE	\$15.00 for 7,500 sq ft or less \$30.00 for 7,501 to 20,000 sq ft \$60.00 for 20,001 sq ft or more
SERVICE STATIONS	\$15.00
MOTELS / HOTELS	\$15.00 per room
RESTAURANTS & BARS	\$60.00
TRAILER COURTS	\$15.00 per trailer
PROFESSIONAL OFFICE	\$15.00
CHURCHES & CLUBS	\$15.00
CAR WASHES & LAUNDRIES	\$60.00
NON-RESIDENT RESIDENTIAL	\$30.00
COLLEGES	Based on the previous year's enrollment (\$0.10 per full time student and \$0.05 per part time student per month) and a charge of \$1.25 per student per month for the capacity of the dormitories. The fee will be divided into equal monthly charges.
SCHOOLS	Based on the previous year's enrollment (\$0.10 per student per month) and a flat fee of \$25.00 per month for the 3 summer months. The fee will be divided into equal monthly charges.
NEW RESIDENTIAL CONNECTION FEE	\$500
NEW NON-RESIDENT CONNECTION FEE	\$1000
NEW COMMERCIAL CONNECTION FEE (Apartments, Hotels, Motels)	\$500 plus \$100 per unit
NEW COMMERCIAL CONNECTION FEE (Multi-Family Units)	\$500 plus \$100 per unit
NEW RESIDENTIAL TAP FEE	\$1000
NEW NON-RESIDENTIAL TAP FEE	\$2000
LATE TAP FEE	\$10 per month per tap

ELECTRIC

RESIDENTIAL ELECTRIC CHARGE	\$.0860/KWH per month \$5.00 per month minimum charge
IRRIGATION ELECTRIC CHARGE	\$.09010/KWH per month \$15.00 per month minimum charge
SMALL COMMERCIAL ELECTRIC CHARGE	\$.09010/KWH per month \$25.00 per month minimum charge
LARGE COMMERCIAL ELECTRIC CHARGE	\$.08576/KWH per month \$25.00 per month minimum charge
TEMPORARY SERVICE ELECTRIC CHARGE	\$.15/KWH per month \$25.00 per month minimum charge

DUSK TO DAWN LIGHT	\$8.00 per month
LATE FEES	1.5% of total bill or \$5.00 per month (whichever is greater)

DEPOSIT FEES FOR NEW SERVICE	\$100.00 per residential service Up to 2-month maximum usage for larger customers
CONNECT FEES FOR ESTABLISHED SERVICES	\$10.00 during regular business hours \$50.00 after business hours
RECONNECT FEES	\$20.00 during regular business hours \$50.00 after business hours
FIELD COLLECTION CHARGE	\$10.00
CONSUMER CAUSED SERVICE CALL	\$200.00 after hours
METER REREAD (IF CORRECT)	\$20.00
METER TEST (IF CORRECT)	\$20.00

METER CHARGE	
RESIDENTIAL	\$10.00
IRRIGATION	\$15.00
SMALL COMMERCIAL	\$20.00
LARGE COMMERCIAL	\$50.00

LOST FIXED COST RECOVERY (LFCR) METER CHARGE FOR DISTRIBUTED GENERATION (DG) CUSTOMERS*	
RESIDENTIAL	\$20.00
IRRIGATION	\$30.00
SMALL COMMERCIAL	\$40.00
LARGE COMMERCIAL	\$100.00

**Regardless of the energy usage in a month, reliable service requires infrastructure (wires, transformers and substations) to be built and maintained. The LFCR recovers a portion of these unrecovered fixed costs resulting from distributed generation.*

TOWN OF THATCHER
US HWY 70 Beautification Grant for 2023
Total of \$20,000 awarded
TOGETHER WE IMAGINE THATCHER BEAUTIFUL!

E.A. GLASS AWARDED \$14,000

Before



After



TOWN OF THATCHER
US HWY 70 Beautification Grant for 2023
Total of \$20,000 awarded
TOGETHER WE IMAGINE THATCHER BEAUTIFUL!

FERRIN'S AUTO COLLISION CENTER AWARDED \$6,000

Before



After



MONTHLY FINANCIAL SUMMARY

August-23

Town of Thatcher

	July 2023	August 2022	September 2022	October 2022	November 2022	December 2022	January 2023	February 2023	March 2023	April 2023	May 2023	June 2023
GENERAL FUND												
TOWN TAXES	\$549,134	\$518,069	\$381,956	\$490,954	\$273,301	\$385,628	\$467,624	\$468,446	\$327,795	\$289,856	\$694,859	\$368,147
SHARED REVENUE	\$218,885	\$167,672	\$189,491	\$174,799	\$165,756	\$182,401	\$164,881	\$191,691	\$186,616	\$188,431	\$171,490	\$198,885
OTHER REVENUES	\$46,422	\$196,693	-\$38,954	\$83,913	\$62,228	\$85,171	\$107,812	\$69,586	\$95,976	\$106,296	\$78,520	\$100,093
TOTAL REVENUE	\$814,441	\$882,435	\$532,492	\$749,666	\$501,285	\$653,200	\$740,318	\$729,723	\$610,388	\$584,583	\$944,869	\$667,124
TOTAL EXPENDITURES	\$711,789	\$754,747	\$1,176,818	\$983,545	\$401,026	\$632,868	\$567,806	\$237,082	\$586,521	\$749,728	\$1,494,700	\$518,655
GENERAL FUND NET	\$102,652	\$127,687	-\$644,326	-\$233,879	\$100,258	\$20,333	\$172,512	\$492,641	\$23,866	-\$165,145	-\$549,832	\$148,470
SEWER FUND												
SEWER REVENUE	\$36,788	\$37,875	\$36,468	\$38,293	\$38,860	\$37,824	\$37,611	\$38,127	\$64,600	\$42,259	\$42,465	\$41,597
SEWER EXPENTITURES	\$19,816	\$51,343	\$81,136	\$24,660	\$17,407	\$32,183	\$35,595	\$16,863	\$27,417	\$28,736	\$23,379	\$64,519
SEWER NET	\$16,972	-\$13,468	-\$44,669	\$13,633	\$21,453	\$5,641	\$2,016	\$21,264	\$37,183	\$13,523	\$19,086	-\$22,922
SANITATION FUND												
SANITATION REVENUE	\$33,385	\$32,912	\$32,763	\$32,982	\$32,566	\$32,722	\$32,735	\$32,759	\$33,010	\$33,233	\$33,290	\$33,321
SANITATION EXPENDITURE	\$25,176	\$37,190	\$32,146	\$32,418	\$44,526	\$33,911	\$29,135	\$18,735	\$40,530	\$32,137	\$27,073	\$29,728
SANITATION NET	\$8,209	-\$4,278	\$618	\$564	-\$11,960	-\$1,188	\$3,600	\$14,024	-\$7,520	\$1,096	\$6,217	\$3,593
ELECTRIC FUND												
ELECTRIC REVENUE	\$761,384	\$591,510	\$560,399	\$396,848	\$292,179	\$340,919	\$500,267	\$432,631	\$350,825	\$457,989	\$472,347	\$613,464
ELECTRIC EXPENDITURES	\$89,305	\$590,803	\$1,175,787	\$513,938	\$524,613	\$672,096	\$191,063	\$969,450	\$183,364	\$487,592	\$348,454	\$197,994
ELECTRIC NET	\$672,079	\$707	-\$615,388	-\$117,090	-\$232,435	-\$331,178	\$309,204	-\$536,819	\$167,461	-\$29,602	\$123,893	\$415,471

